

Engineering Release Notice (ERN)	Location	Change Description	A = Added D = Deleted	W = Was	Document Release Status
		See DCN			Date RELEASED Modification Count

WIRING DIAGRAM INDEX

NAME	DESCRIPTION	PAGE
AA	12/24V CHASSIS FUSEBOX	3
AA1	ELECTRICAL CENTER CHASSIS	4
AA4	ELECTRICAL CENTER CAB	5
AB	POWER DISTRIBUTION DESS 2.0	6
AC	POWER DISTRIBUTION SESS	7
AD	POWER DISTRIBUTION	8
AE	POWER DISTRIBUTION CCIOM2	9
AF	FUNCTIONAL MAIN SWITCH	10
AG	AFTERTREATMENT	11
AI	IGNITION SWITCH	12
BA	DISPLAY	13
BE	VEHICLE MASTER CONTROL UNIT	14
BG	SECURITY & CAB INTERFACE MODULE (SCIM)	15
BU	TIS - TELEMATICS SERVICES	16
BU1	TIS - TELEMATICS SERVICES	17
BX	RP1226	18
CA	ENGINE INTERFACE	19
CA1	ENGINE INTERFACE	20
CD1	AFTERTREATMENT	21
CK	AFTERTREATMENT SYSTEM	22
CL	AFTERTREATMENT SYSTEM HIGHWAY	23
DC	TRANSMISSION	24
DE	ALLISON	25
EE	EBS HIGHWAY	26
EF	EBS FRONT AXLE	27
EG	EBS 6S6M HIGHWAY	28
EH	EBS OPTIONAL	29
EI	EBS TRAILER	30
FA	AIR SUSPENSION 4X2, 6X4	31
FB	AIR SUSPENSION	32
FC	AIR SUSPENSION	33
FD	AIR SUSPENSION	34
FE	AIR MANAGEMENT HIGHWAY	35
FI	FRONT AXLE STEERING	36
FL	LEAF SUSPENSION	37
FL1	LEAF SUSPENSION	38
FM	AIR SUSPENSION	39
GA	EXTERIOR LIGHT, FRONT, LEFT	40
GB	EXTERIOR LIGHT, FRONT, RIGHT	41
GC	EXTERIOR LIGHTS TL-LED	42
GC1	EXTERIOR LIGHTS EXPORT	43
GC2	EXTERIOR LIGHTS TL-MULT2	44
GC3	EXTERIOR LIGHTS TL-LED3	45
GD	EXTERIOR LIGHT, MIRROR	46
GF	EXTERIOR LIGHTS, ROOF	47
GP	WIPER AND WASHER	48
HA	CLIMATE UNIT	49
HA1	CLIMATE UNIT	50
HA2	WINDSHIELD HEATER	51
HB	IPC	52
HC	PARKING HEATER - WATER	53
HD	PARKING HEATER - AIR	54
HE	AMBIENT TEMP., SHORT STOP HEATER	55
HF	AIR FILTER MONITORING	56
IA1	INTERIOR LIGHTS	57
IA2	INTERIOR LIGHTS	58
IB	INTERIOR LIGHTS BASE	59
IC	INTERIOR LIGHTS	60
IE1	INTERIOR LIGHTS HIGH	61
IE2	INTERIOR LIGHTS MID	62

NAME	DESCRIPTION	PAGE
IF	COMFORT ACCESSORIES USBS AND FRIDGE	63
IG	COMFORT ACCESSORIES PDC	64
IG1	COMFORT ACCESSORIES PDC	65
IG2	COMFORT ACCESSORIES PDC	66
IH	COMFORT ACCESSORIES 120VAC	67
IK	INFOTAINMENT, SEM2	68
IL	INFOTAINMENT 24V AMPLIFIER	69
IN	INFOTAINMENT TV ANTENNA	70
IO	INFOTAINMENT SEM2	71
IO1	INFOTAINMENT CAMERAS	72
IO2	INFOTAINMENT USB-C	73
IP	HORN	74
IR	DOOR DS	75
IS	DOOR PS	76
IT	SEATS	77
KC	TPMS	78
NA	BODYBUILDER BBM POWER	79
NB	BODYBUILDER VMCU	80
NC	BODYBUILDER 5TH WHEEL	81
ND	BODYBUILDER 12V BBEC	82
ND1	BODY BUILDER 24V BBEC	83
NE	BODY BUILDER LIGHTS	84
NE_1	BODY BUILDER LIGHTS	85
NF	BODY BUILDER 12V AUX SWITCHES	86
NF1	BODYBUILDER 24V AUX SWITCHES	87
NG	BODYBUILDER BBEC AUX SWITCHES	88
NI	BODYBUILDER COMMON INTERFACE	89
NL2	BODYBUILDER 24V BODYLINK	90
NL4	BODYBUILDER BBM1 BBCHAS4	91
NL5	BODYBUILDER 12V BODYLINK	92
NM	BODYBUILDER 12V RP170	93
NT	BODYBUILDER TRAILER	94
NT1	BODYBUILDER TRAILER	95
NT2	BODYBUILDER TRAILER EXTENSION	96
PA	DRIVER ASSISTANCE CONTROL UNIT	97
PA1	SAFETY, DACU3.2	98
PB	SAFETY, DACU3.2	99
PC	PASSIVE SAFETY	100
SA	BACKBONE 1	101
SB	BACKBONE 2	102
SC	CAB SUBNET	103
SD	SECURITY SUBNET	104
SE	CHASSIS SUBNET	105
SF	CHASSIS SUBNET	106
SH	INFOTAINMENT SUBNET	107
SK	SWITCH TOPOLOGY	108
SK1	SWITCH TOPOLOGY MACK AREA 1 - 3	109
SK2	ECS DAY CAB	110
SL	INSTRUMENT CLUSTER SWITCHES	111
XA	OBD INTERFACE	112
XF	BACKBONE 1 CHASSIS	113
YA	BIW - CAB GROUND ECU INSTRUMENT PANEL	114
YB	BIW - CAB GROUND INSTRUMENT PANEL	115
YC	BIW - CAB GROUND INSTUMENT PANEL	116
YD	BIW - CAB GROUND - PASSENGER SIDE B-PILL	117
YD1	BIW-CAB GROUND REAR WALL DAY	118
YE	BIW - CAB GROUND	119
YF	CHASSIS GND	120
YG	CHASSIS GND	121
YH	CHASSIS GROUND	122

The copying, distribution and utilization of this document as well as the communication of its contents to others without expressed authorization is prohibited. Offenders will be held liable for payment of damages. All rights reserved in the event of the grant of a patent, utility model or ornamental design registration.

Document title

WIRING DIAGRAM, TEA2+ DIESEL

The legal owner of this document is as stated under "Design Location" in KOLA and in the associated "Part Version Report"

Document type

PRODUCT SCHEMATICS

Document No

24798720

Issue

01

Volume

1(1)

Sheet No

1 (125)

VOLVO

Engineering Release Notice (ERN)	Location	Change Description	A = Added D = Deleted	W = Was	Document Release Status
		See DCN			Date Modification Count

WIRING DIAGRAM INDEX

NAME	DESCRIPTION	PAGE
YJ	BIW - CAB GROUND	123
YK	BIW-CAB GROUND FROTN OVERHEAD	124

NAME	DESCRIPTION	PAGE
YL	BIW-CAB GROUND FLOOR	125

The copying, distribution and utilization of this document as well as the communication of its contents to others without expressed authorization is prohibited. Offenders will be held liable for payment of damages. All rights reserved in the event of the grant of a patent, utility model or ornamental design registration.

Document title

WIRING DIAGRAM, TEA2+ DIESEL

VOLVO

The legal owner of this document is as stated under "Design Location" in KOLA and in the associated "Part Version Report"

Document type

PRODUCT SCHEMATICS

Document No

24798720

Issue

01

Volume

1(1)

Sheet No

2 (125)

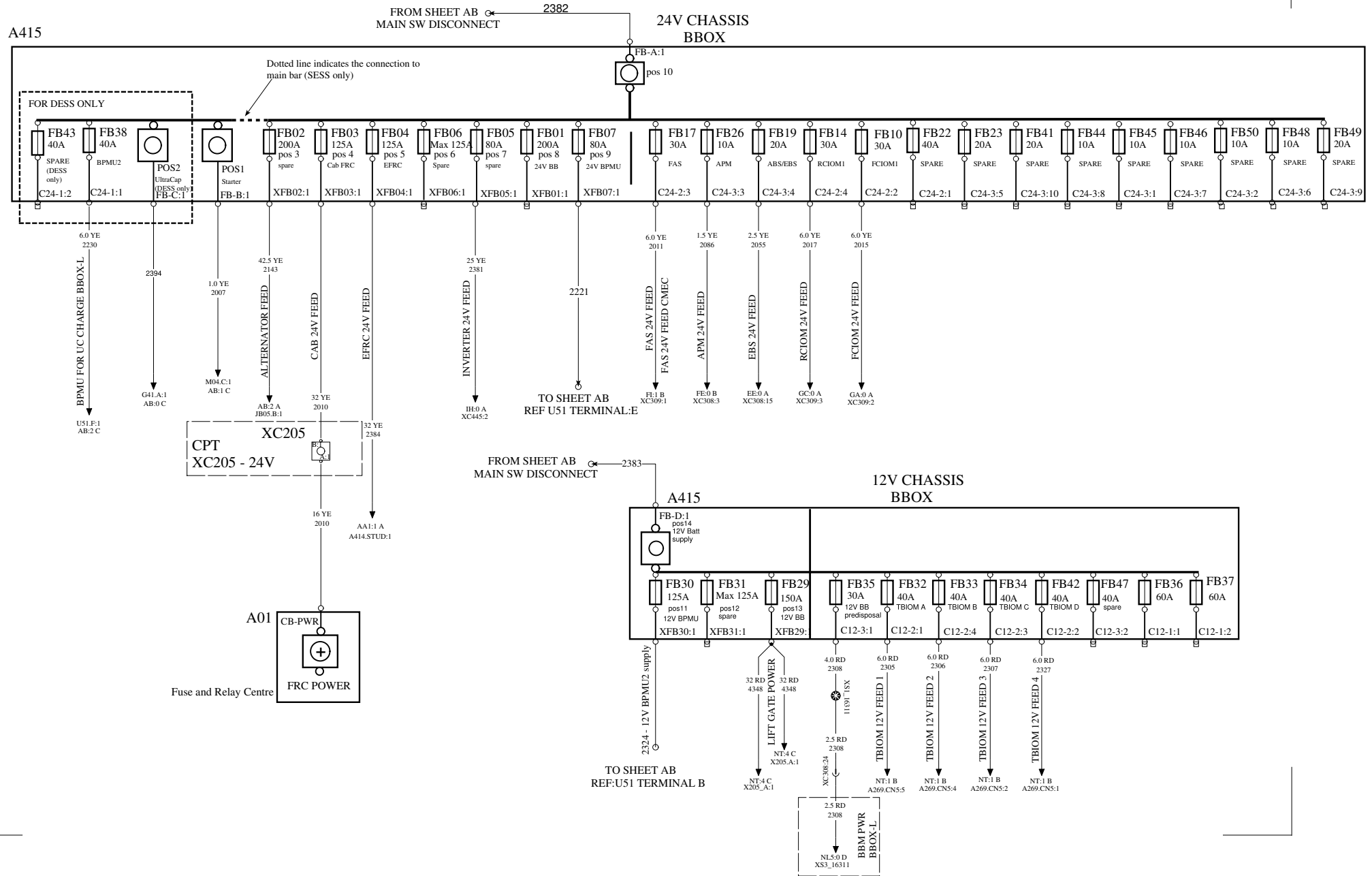

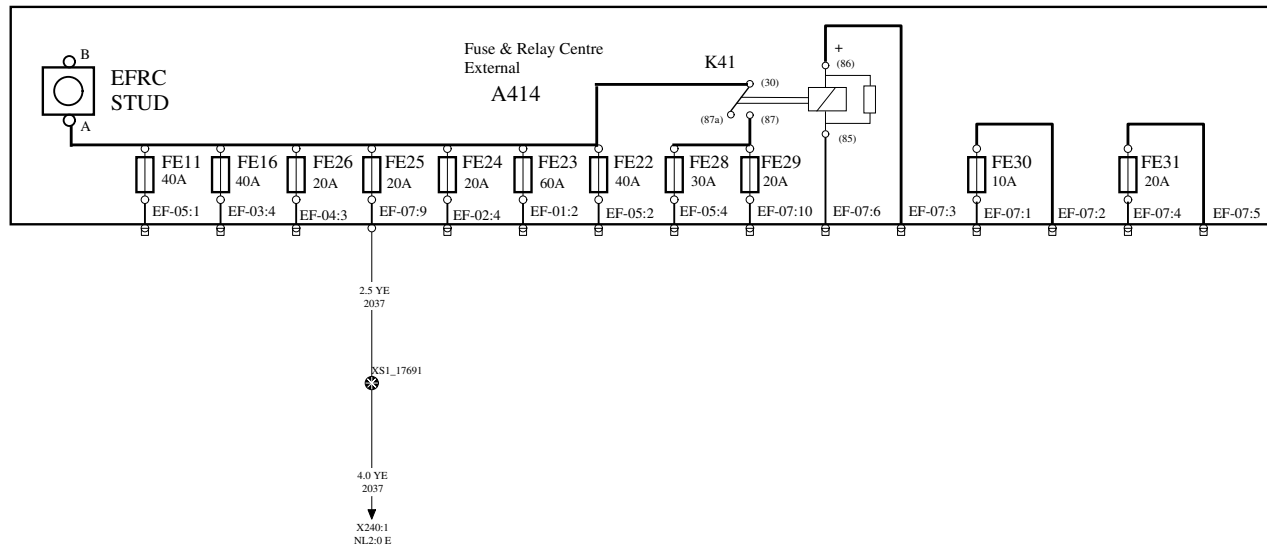
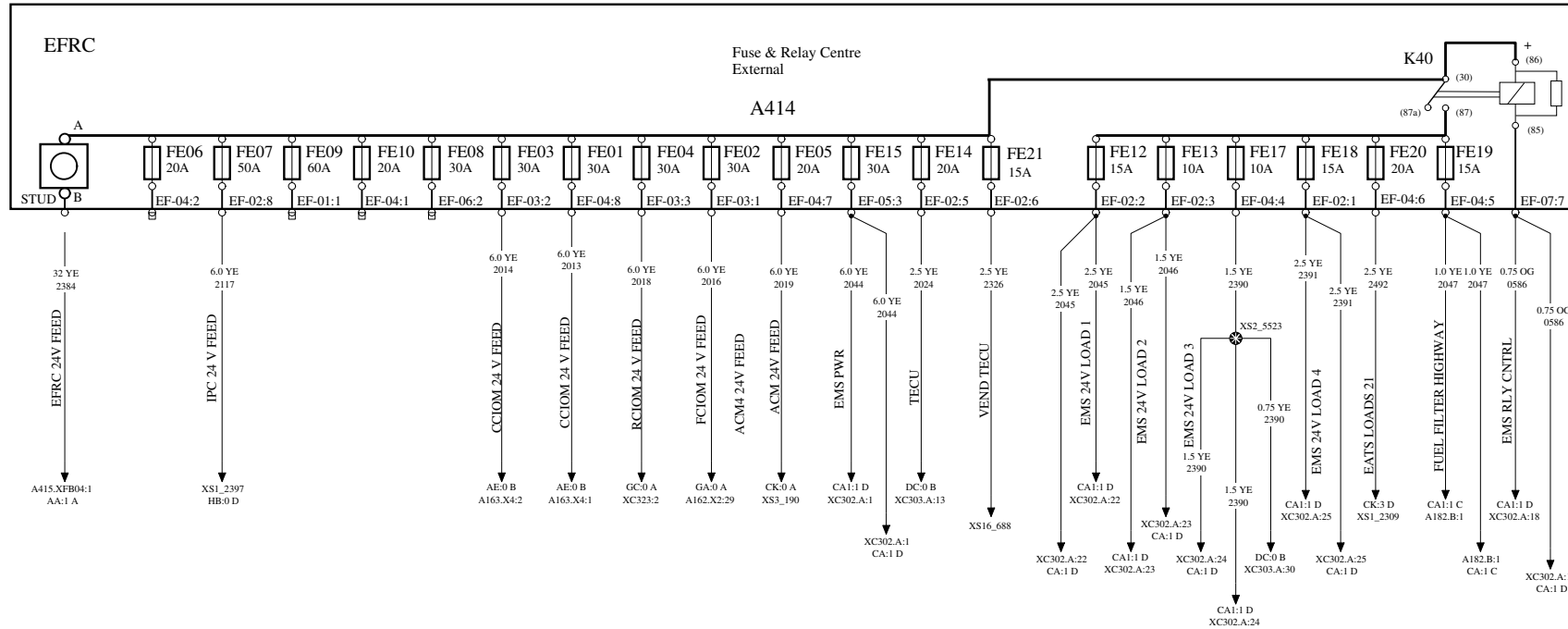

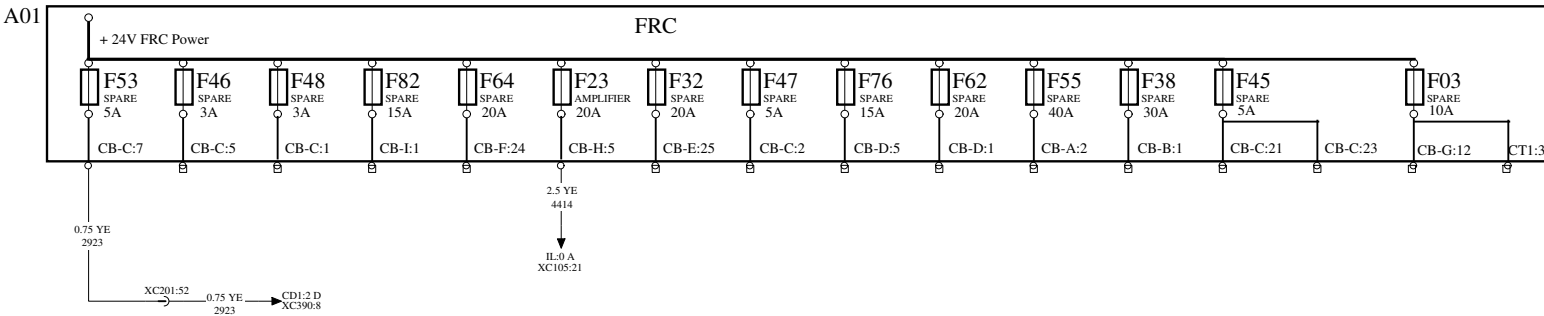
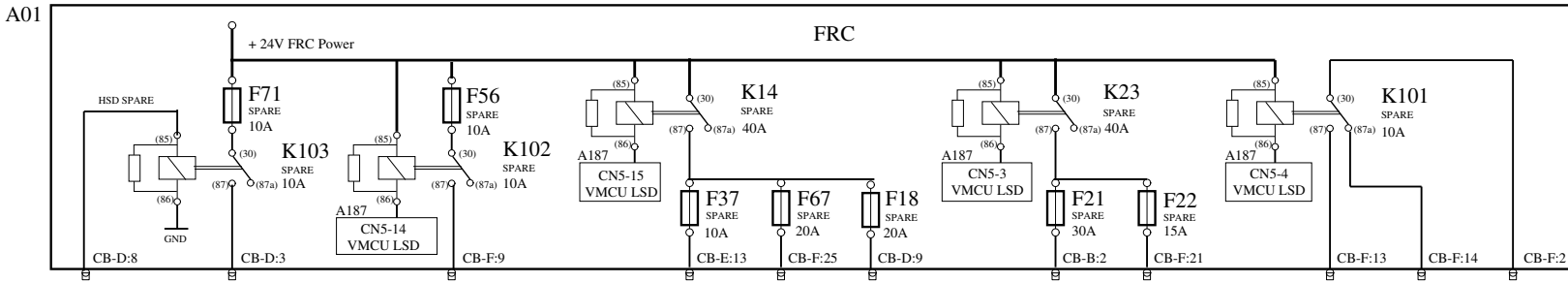
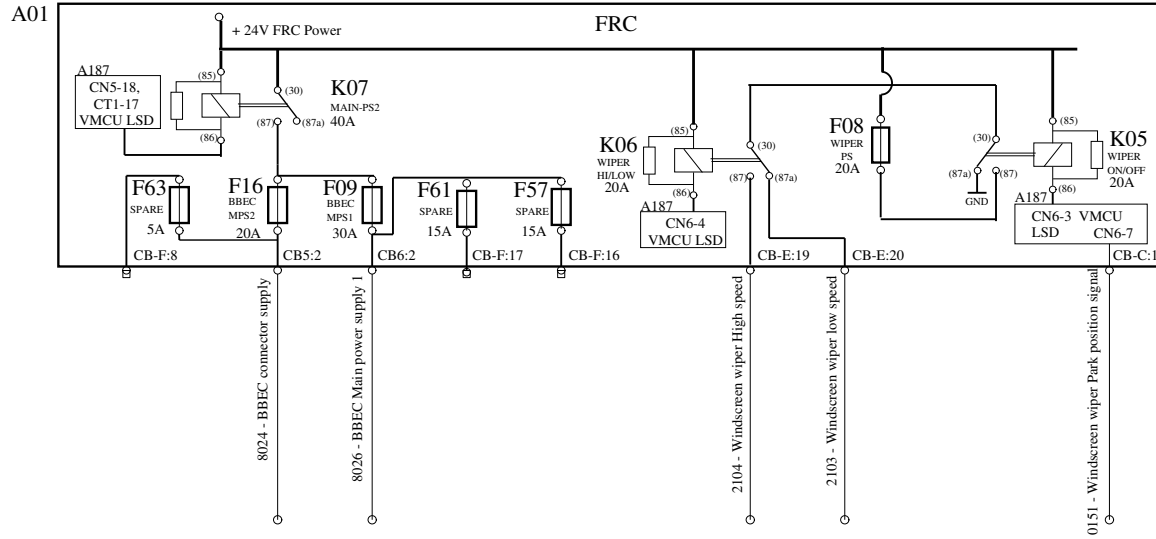

Document title
WIRING DIAGRAM, TEA2+ DIESEL

Legal Owner
Volvo Truck Corporation

Document No

24798720

Issue

01

Volume

1(1)

Page

5 (125)

POWER DISTRIBUTION DESS 2.0

WIRING DIAGRAM AB

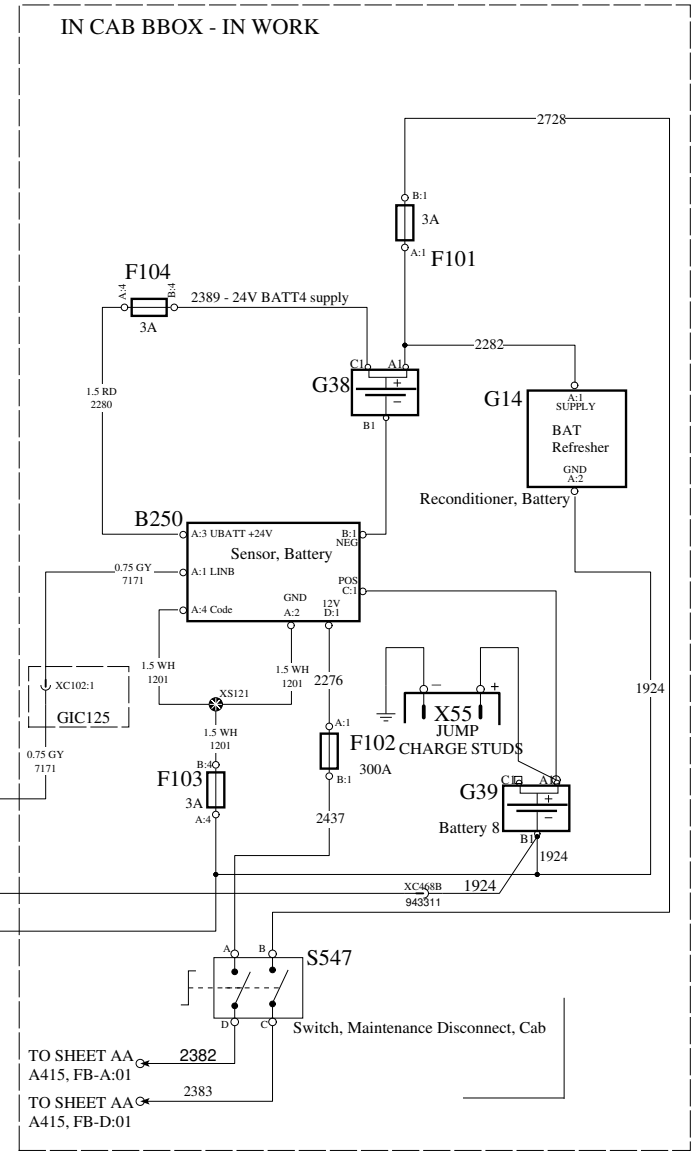
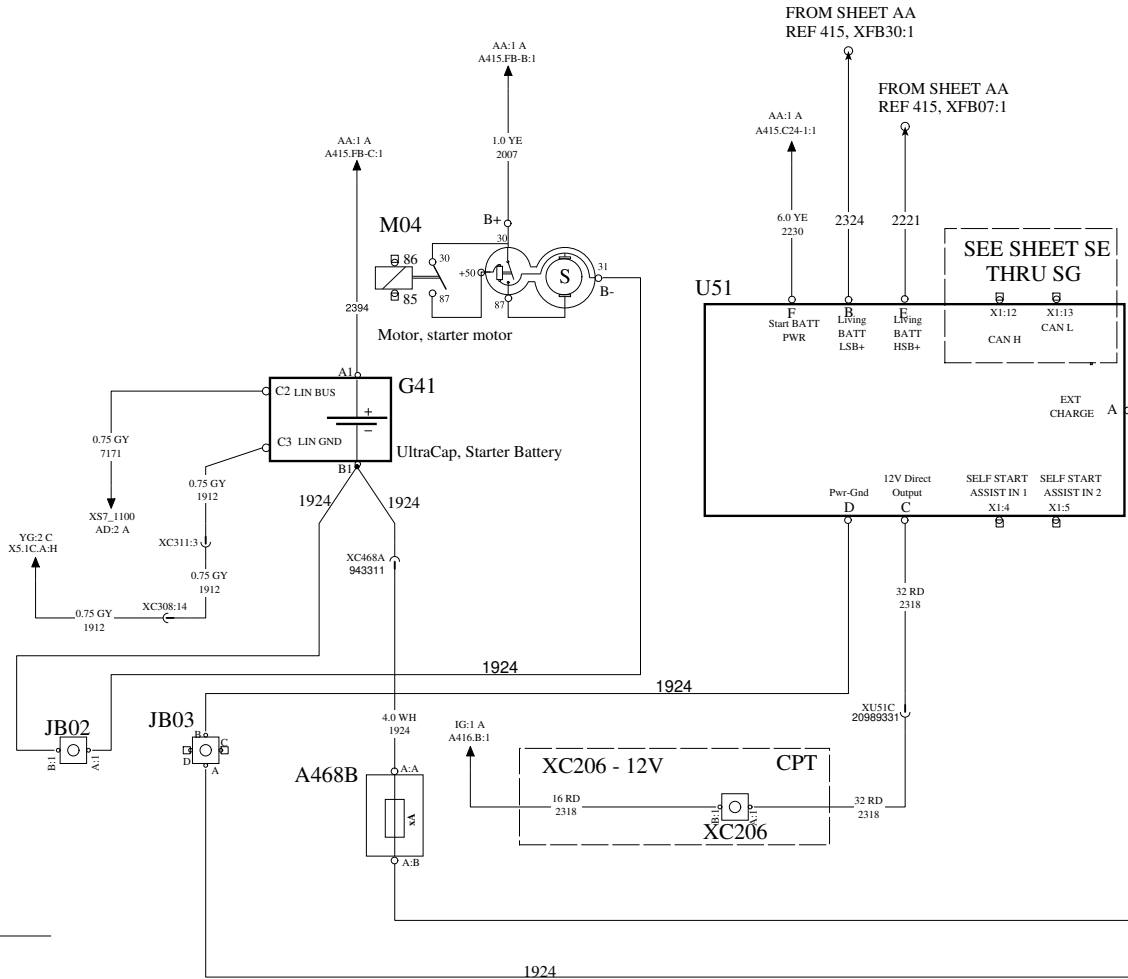
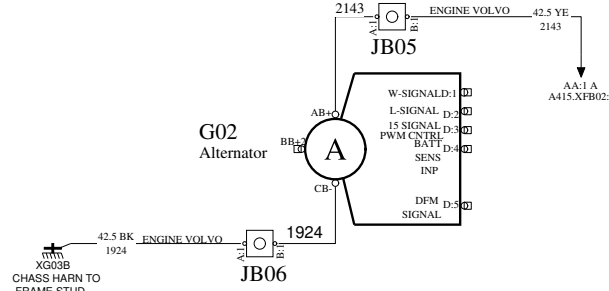
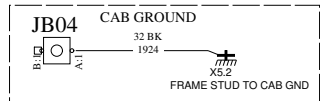

Document title
WIRING DIAGRAM, TEA2+ DIESEL
 Legal Owner
Volvo Truck Corporation

Document No

24798720

Issue

01

Volume

1(1)

Page

6 (125)

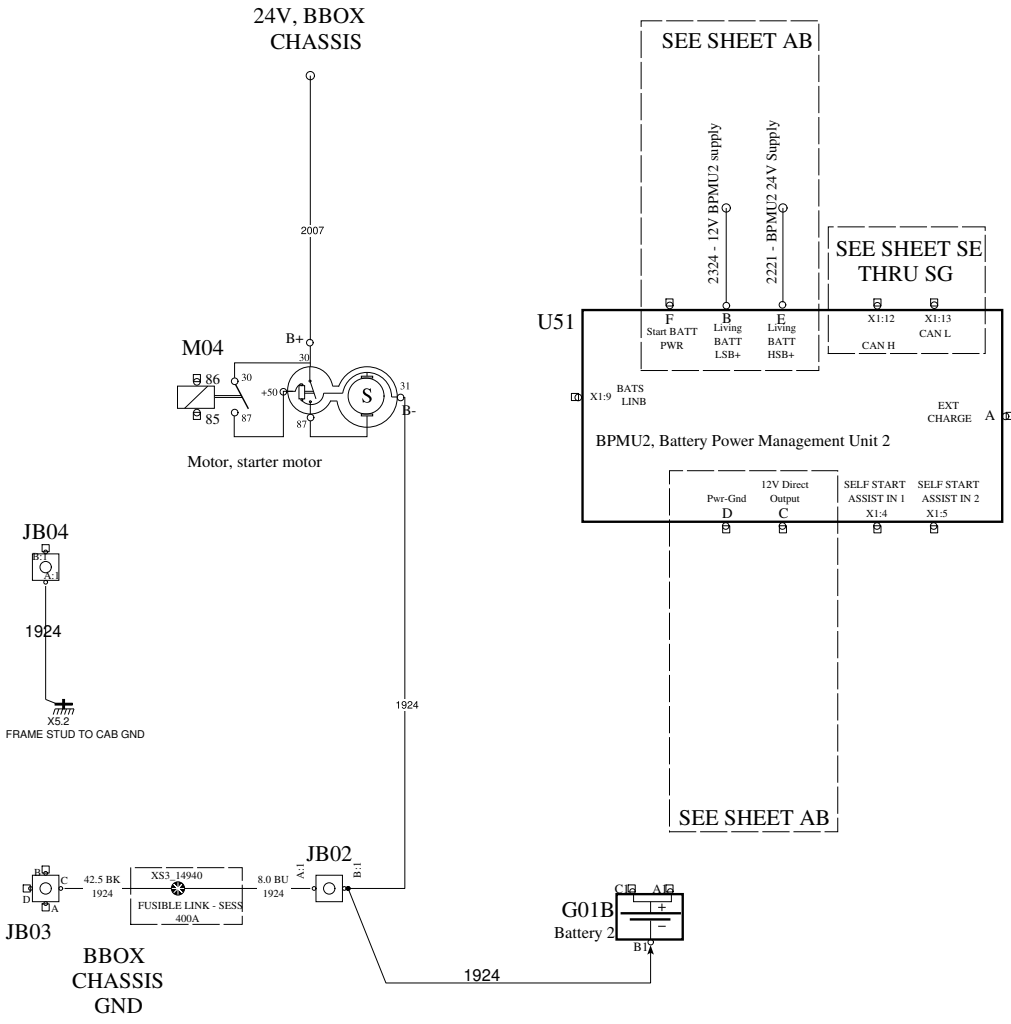

SEE SHEET AB

SEE SHEET SE THRU SG

SEE SHEET AB

Document title WIRING DIAGRAM, TEA2+ DIESEL		Document No	Issue	Volume	Page
Legal Owner Volvo Truck Corporation		24798720	01	1(1)	7 (125)

POWER DISTRIBUTION

BBOX CHASSIS

WIRING DIAGRAM AD

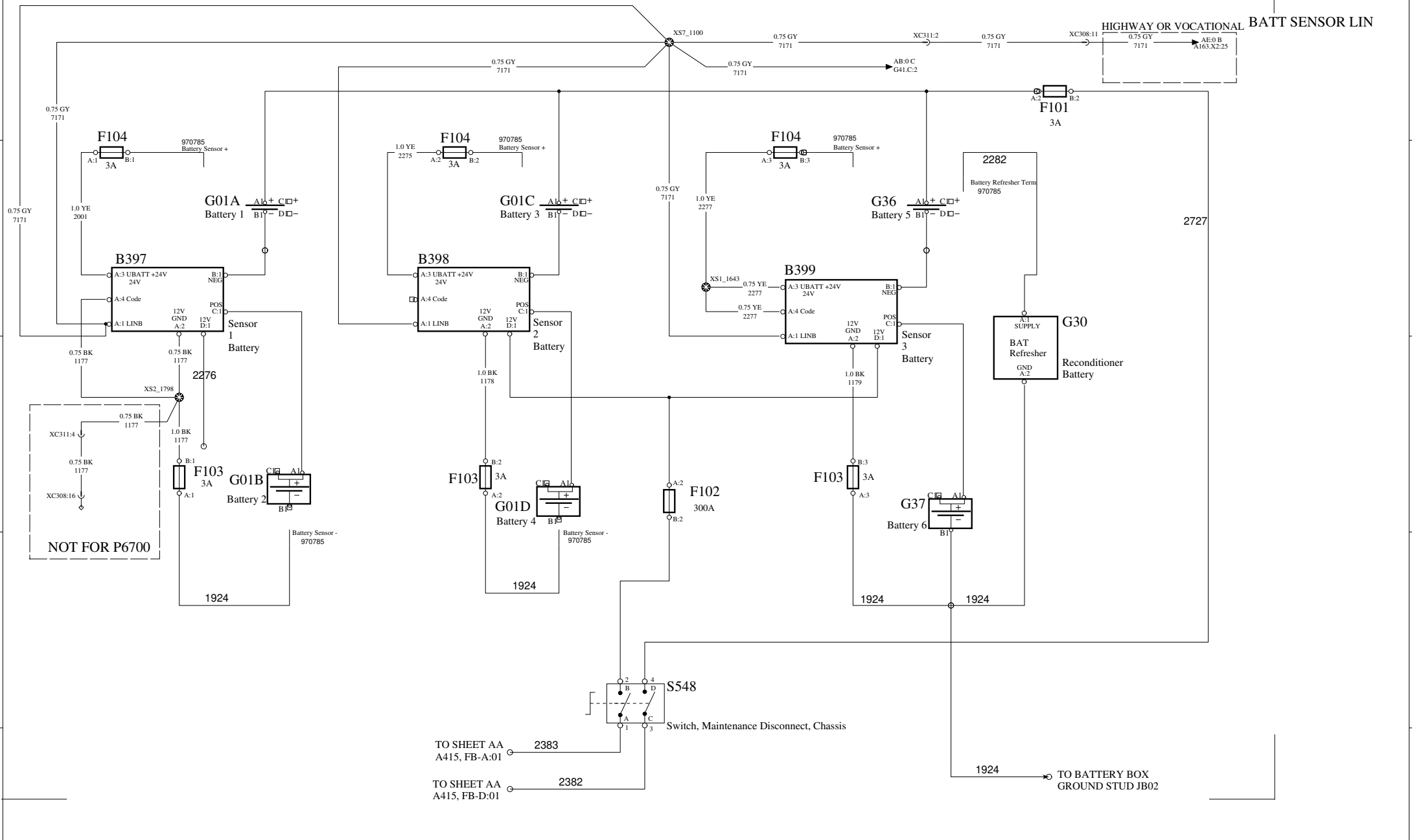

Document title WIRING DIAGRAM, TEA2+ DIESEL		Document No	Issue	Volume	Page
Legal Owner Volvo Truck Corporation		24798720	01	1(1)	8 (125)

POWER DISTRIBUTION CCIOM2

CCIOM2

WIRING DIAGRAM AE

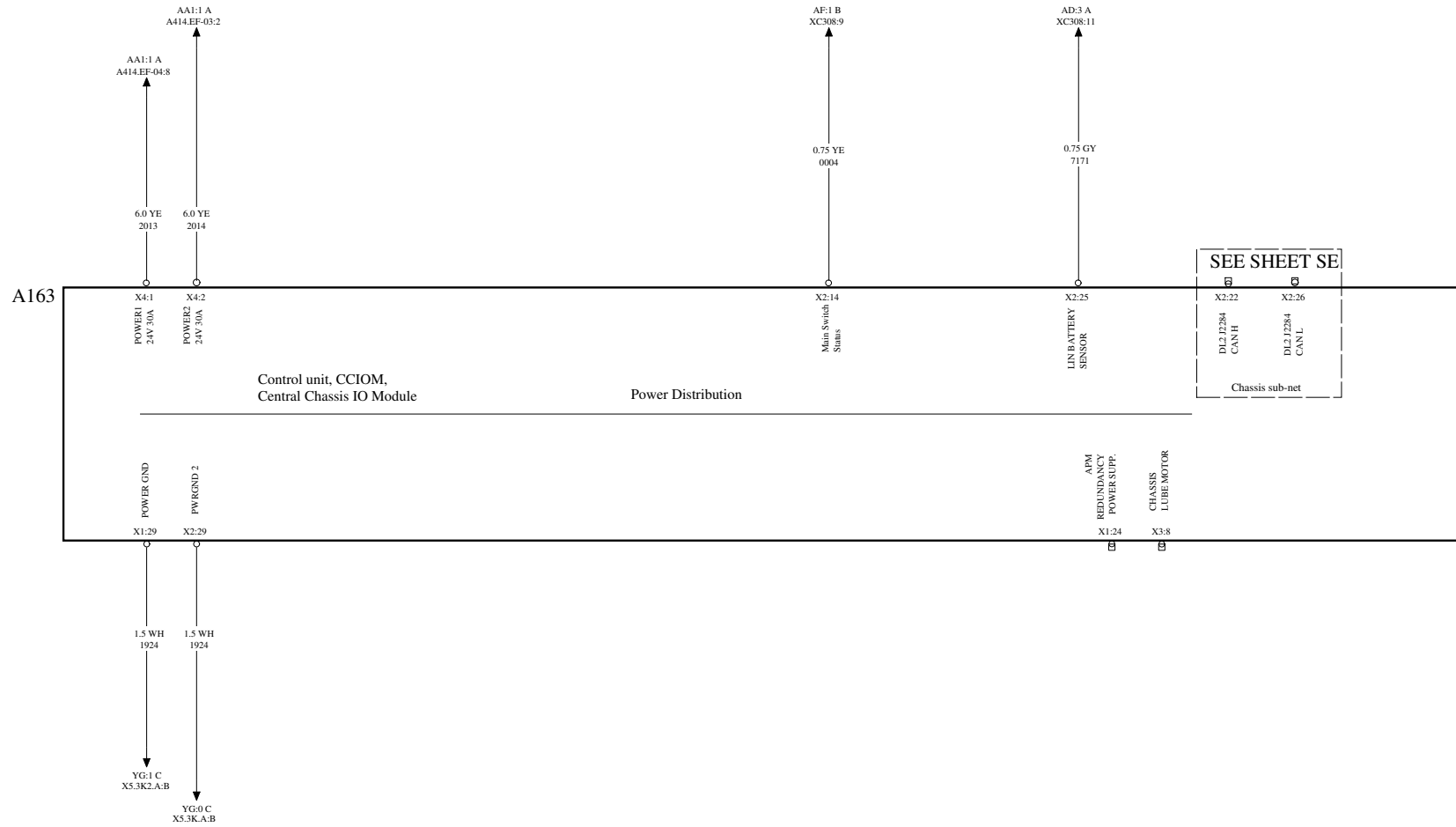

V O L V O

Document title
WIRING DIAGRAM, TEA2+ DIESEL

Legal Owner
Volvo Truck Corporation

Document No

24798720

Issue

01

Volume

1(1)

Page

9 (125)

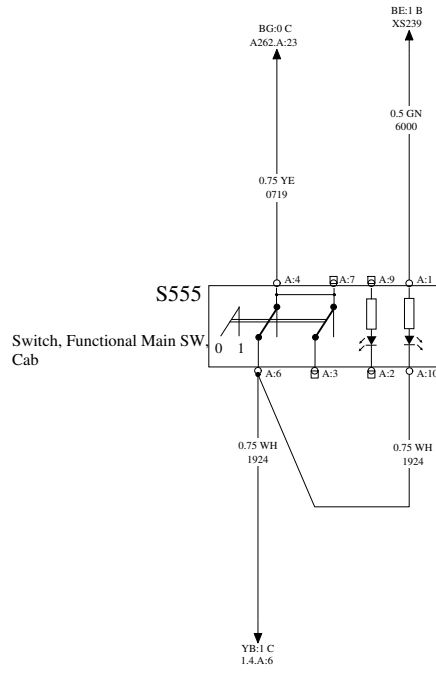
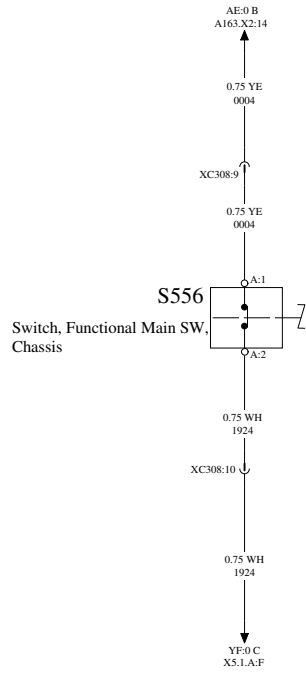

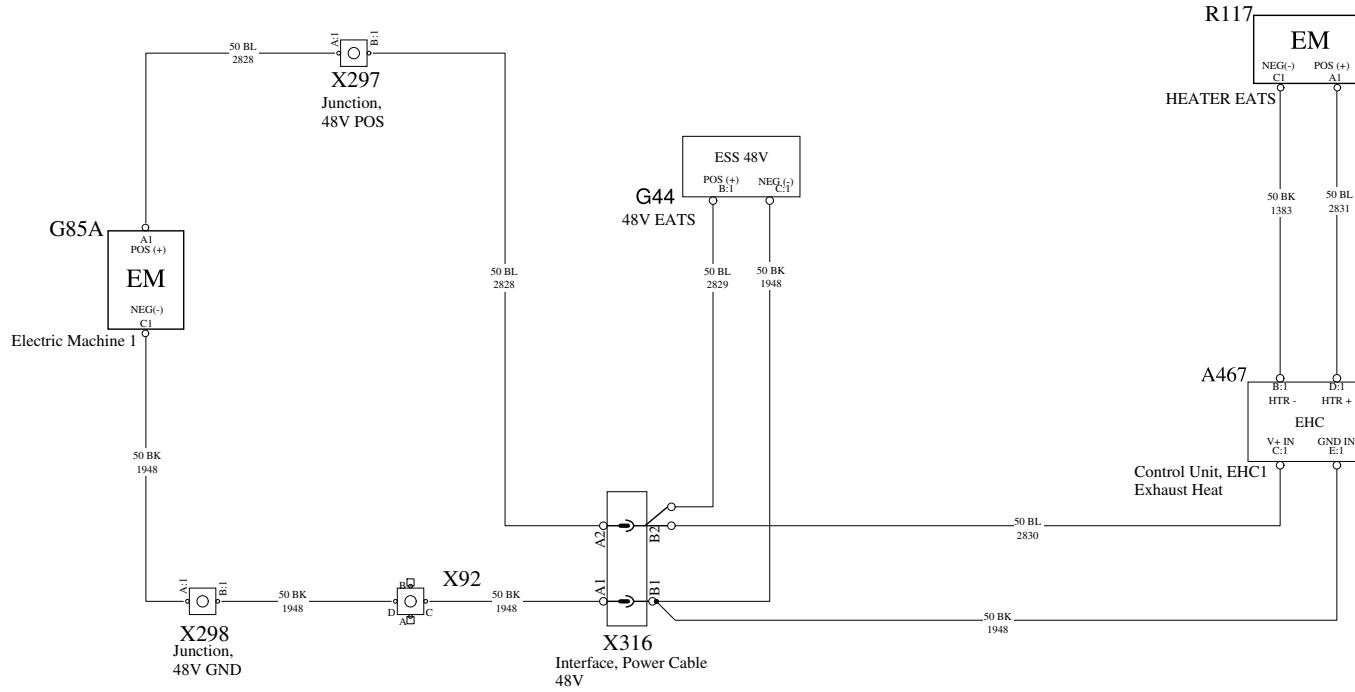

IGNITION SWITCH

WIRING DIAGRAM AI

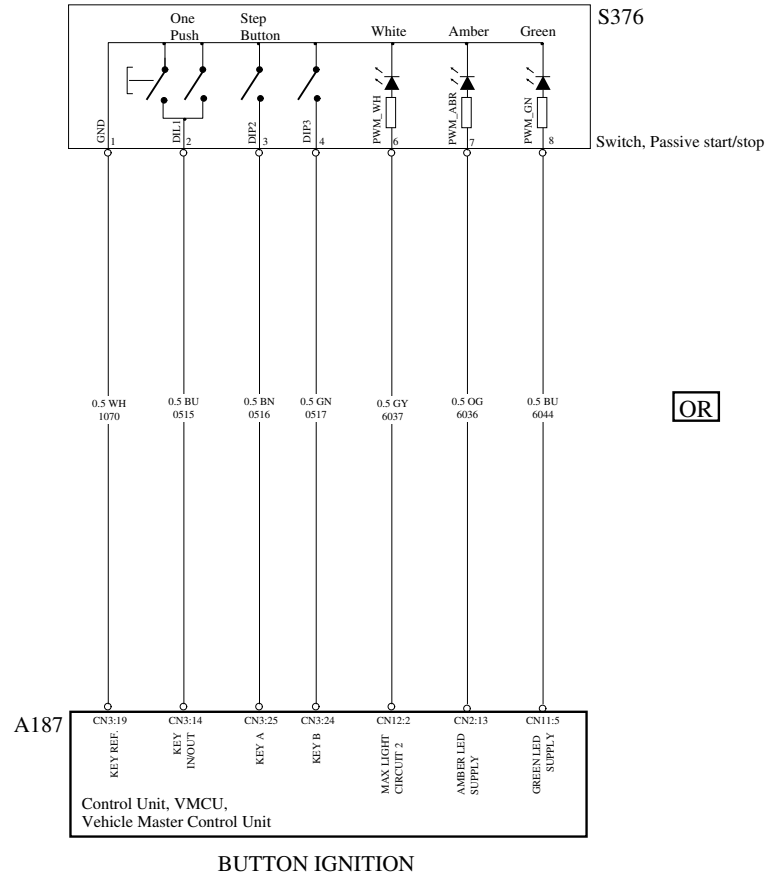

OR

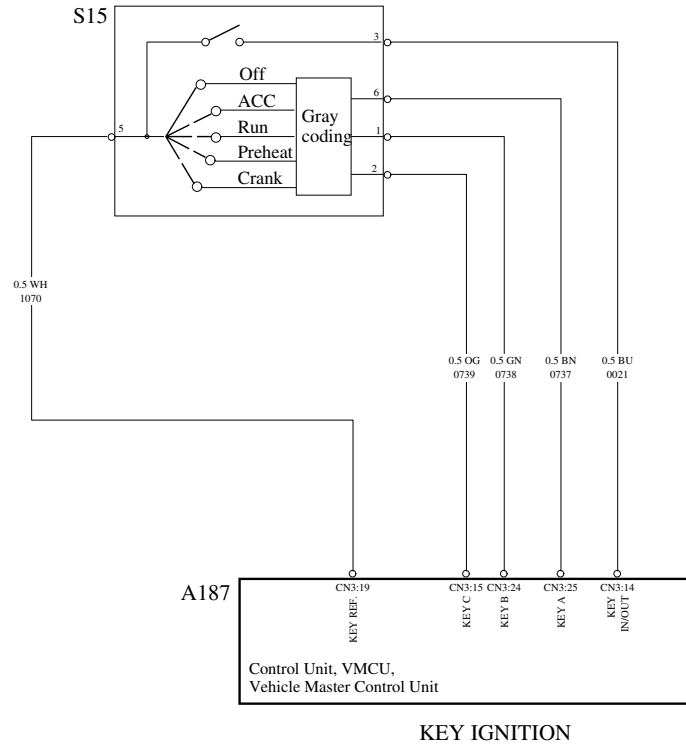

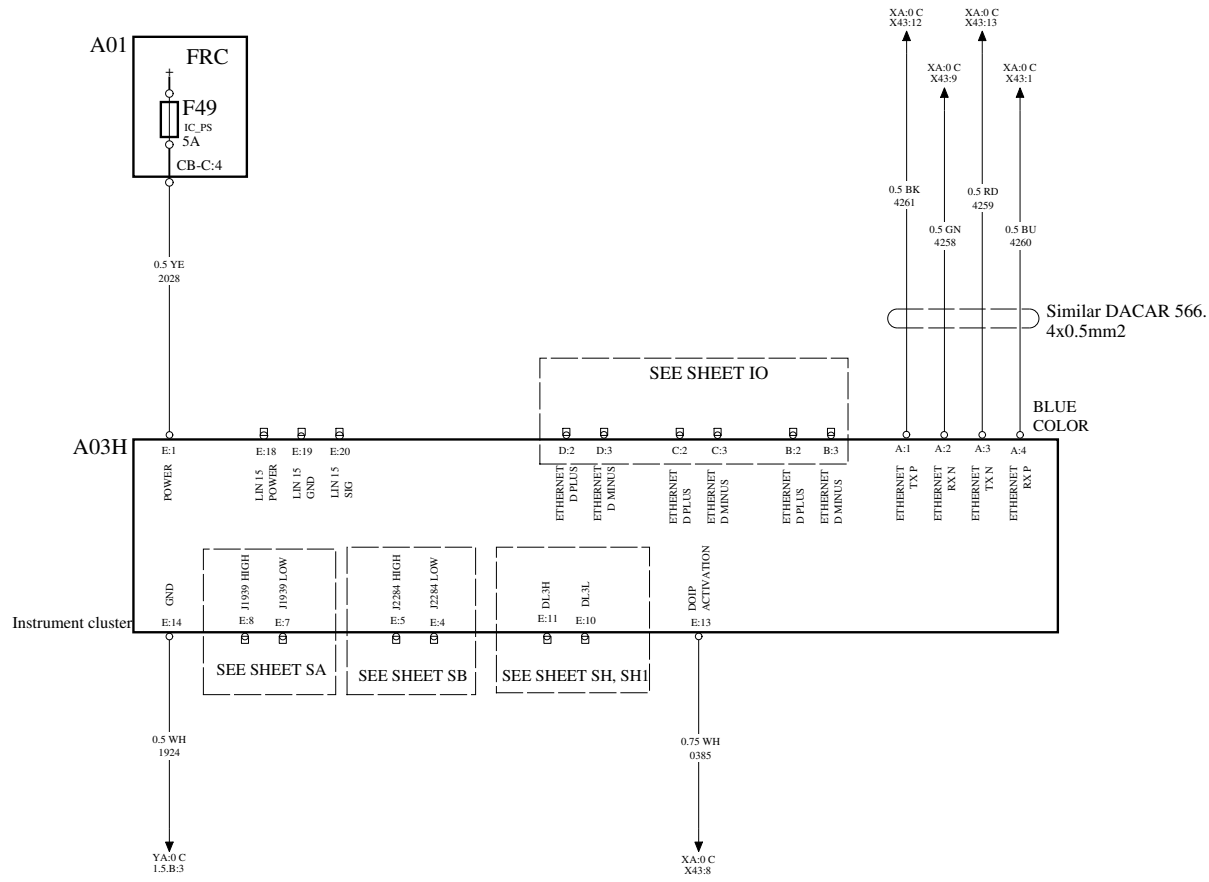

VEHICLE MASTER CONTROL UNIT

WIRING DIAGRAM BE

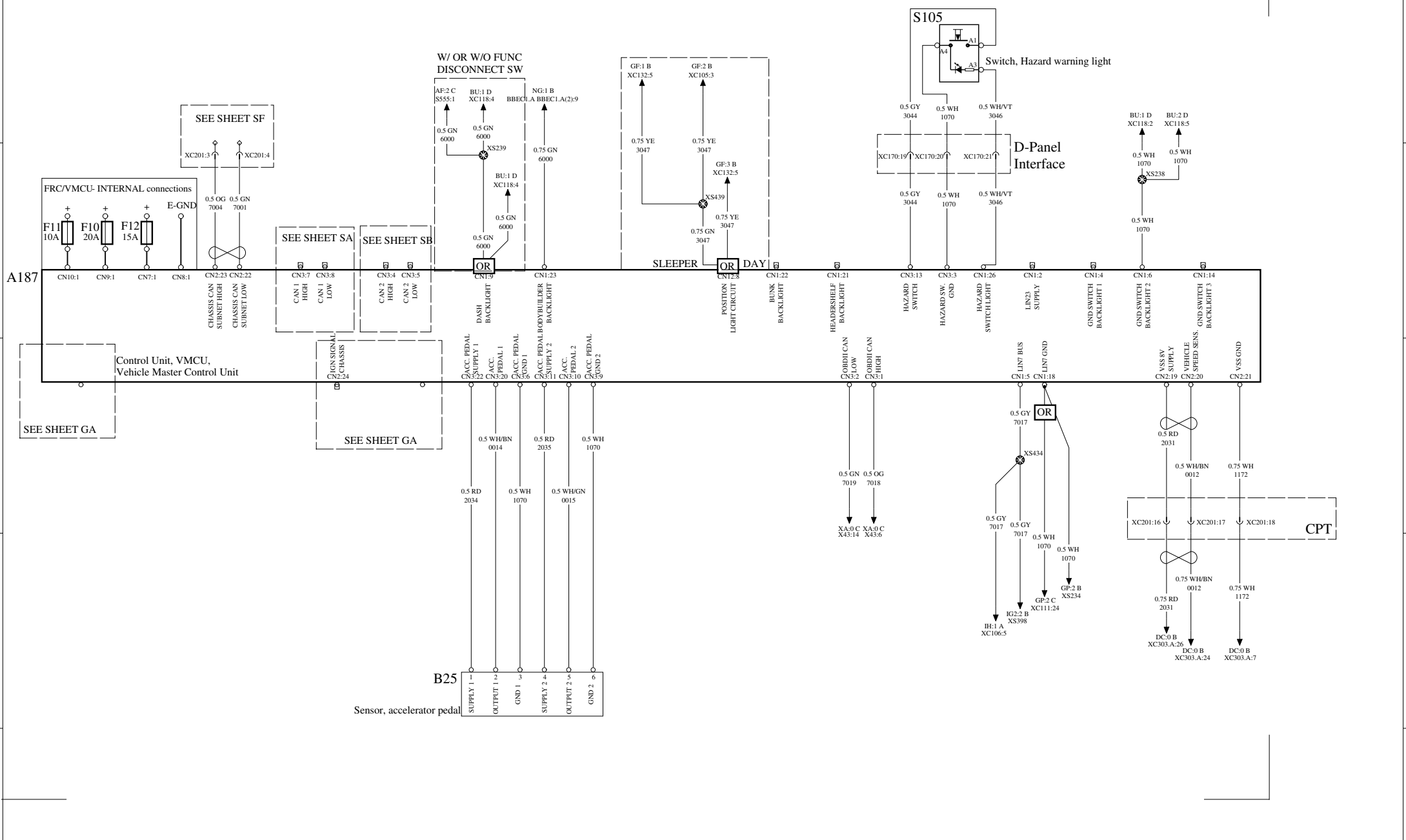

Document title
WIRING DIAGRAM, TEA2+ DIESEL

Legal Owner
Volvo Truck Corporation

Document No

24798720

Issue

01

Volume

1(1)

Page

14 (125)

SECURITY & CAB INTERFACE MODULE (SCIM)

WIRING DIAGRAM BG

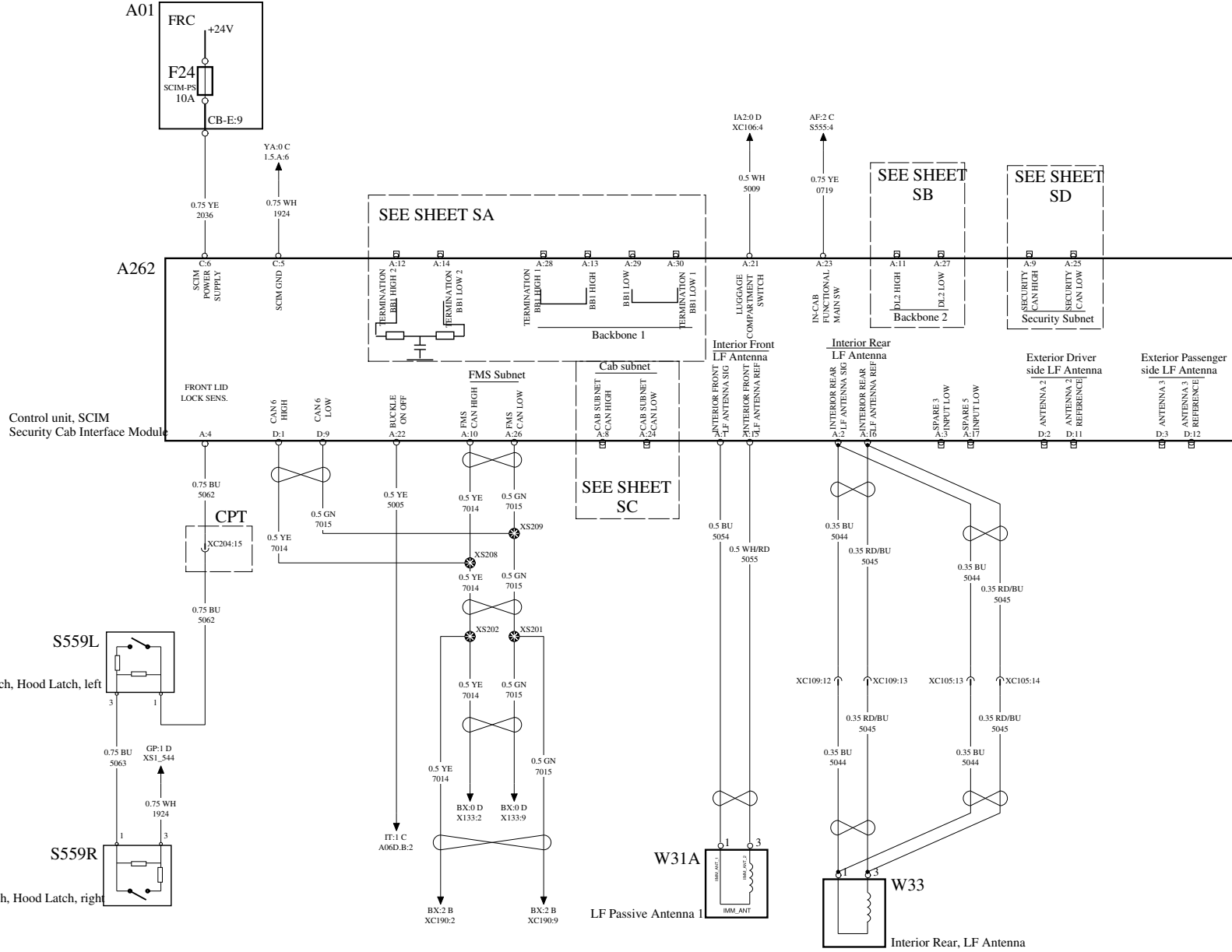

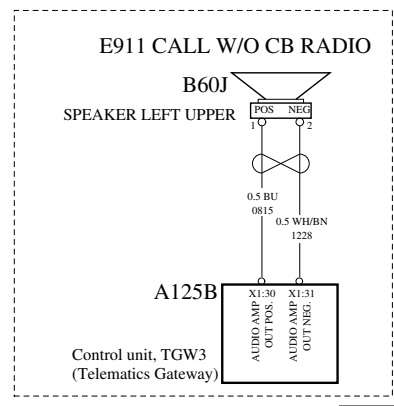
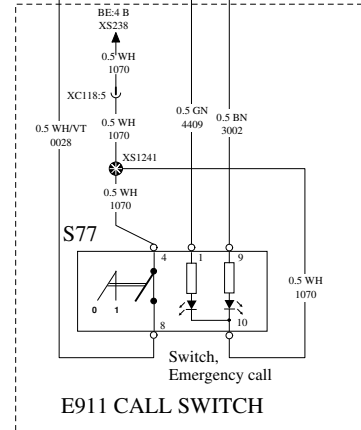
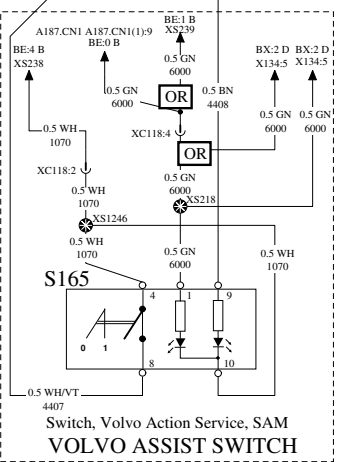
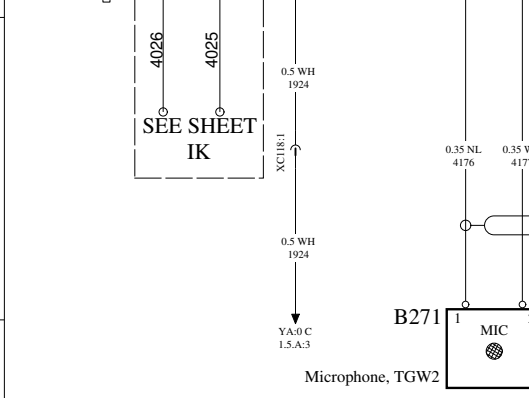
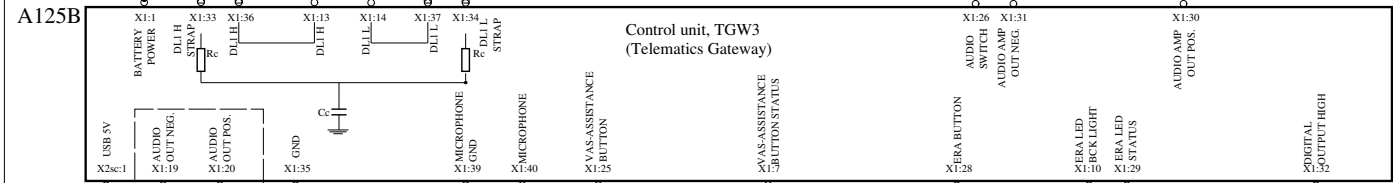
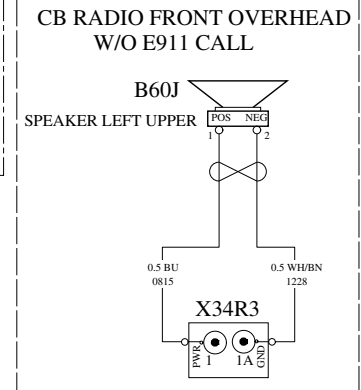
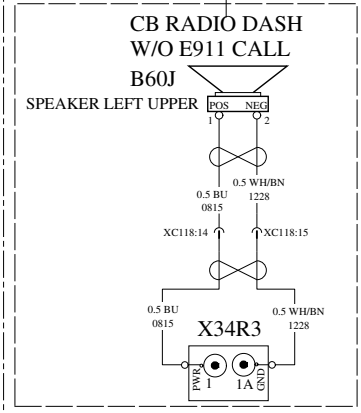
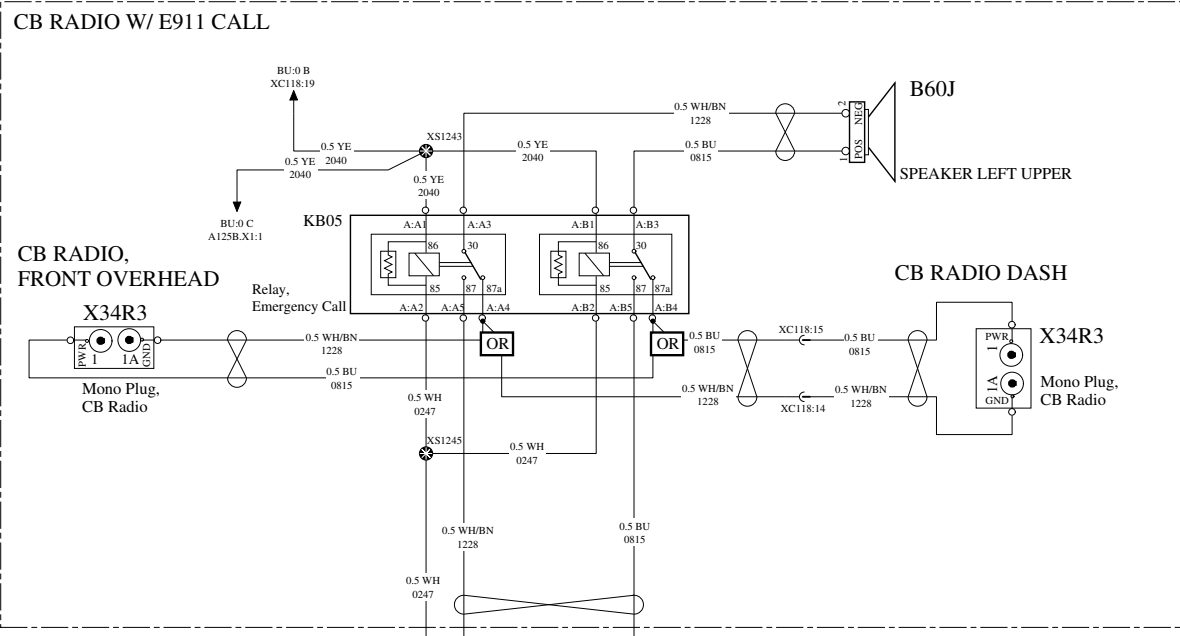
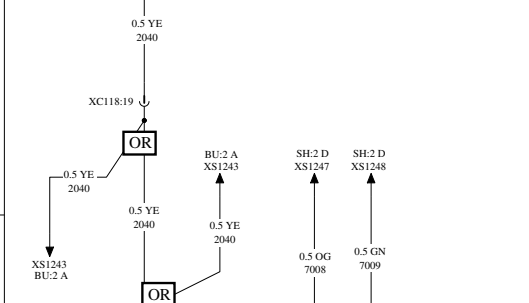
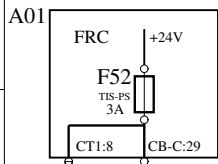

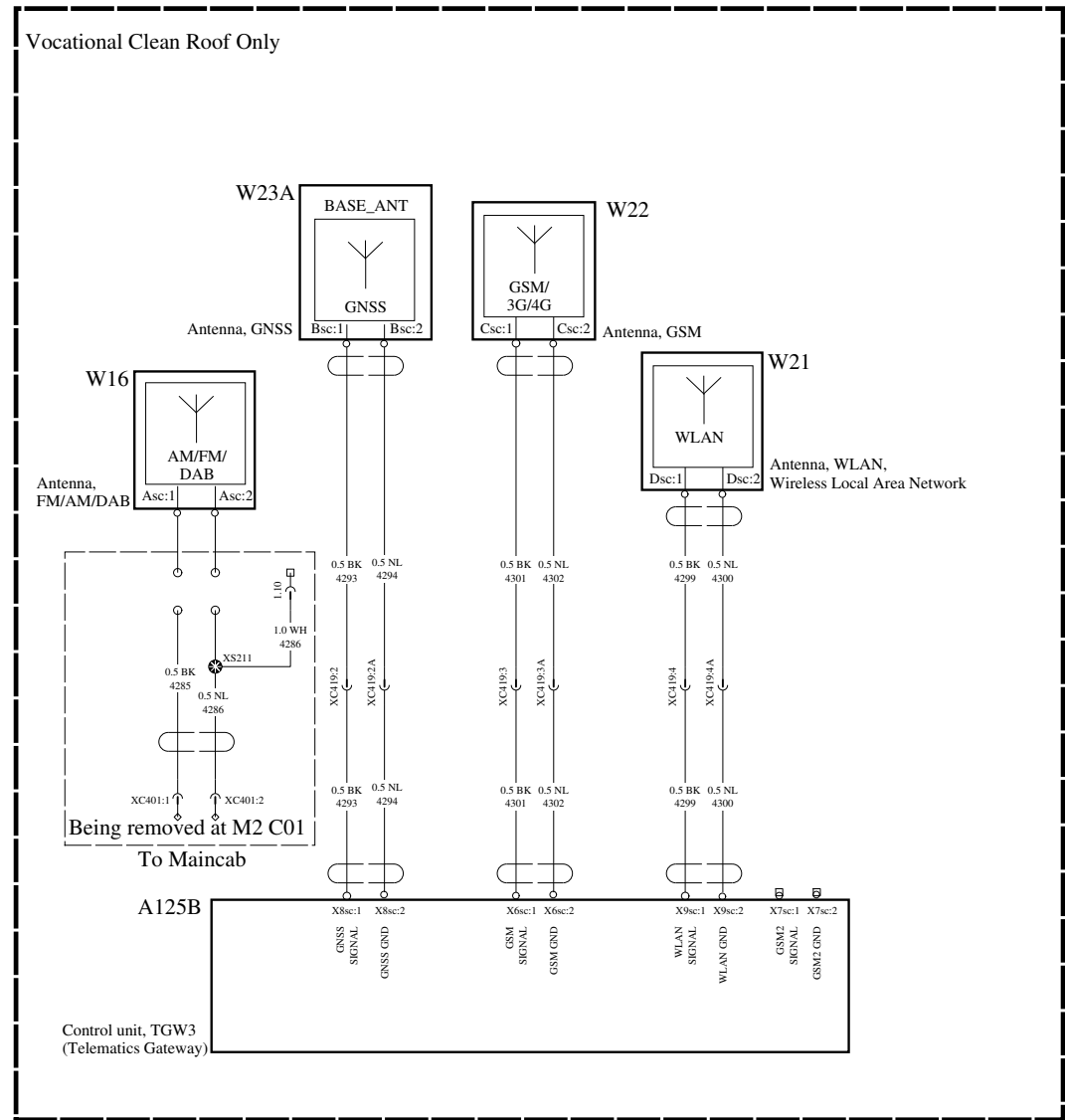
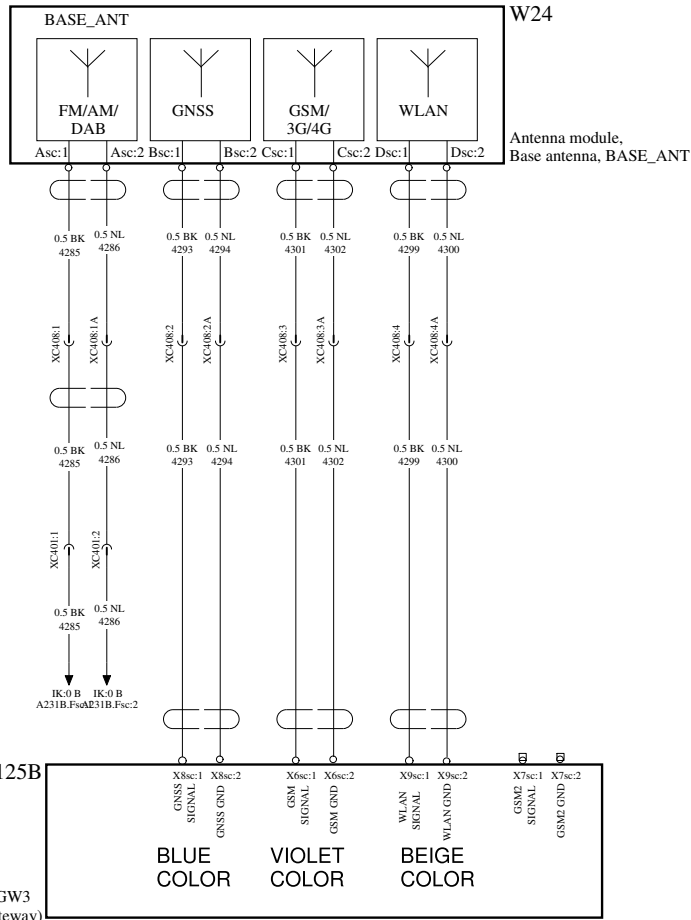

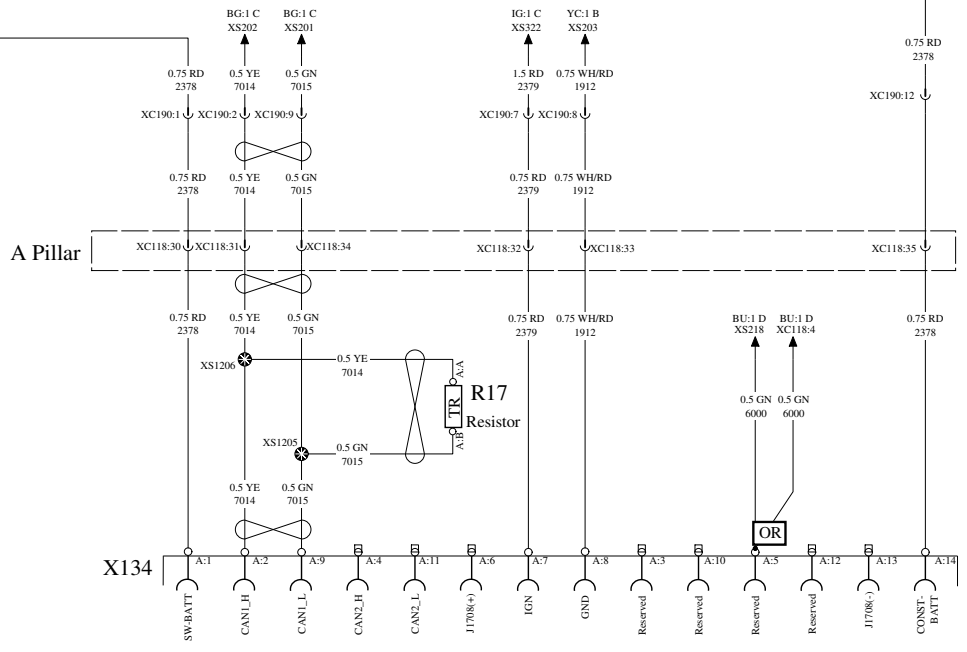
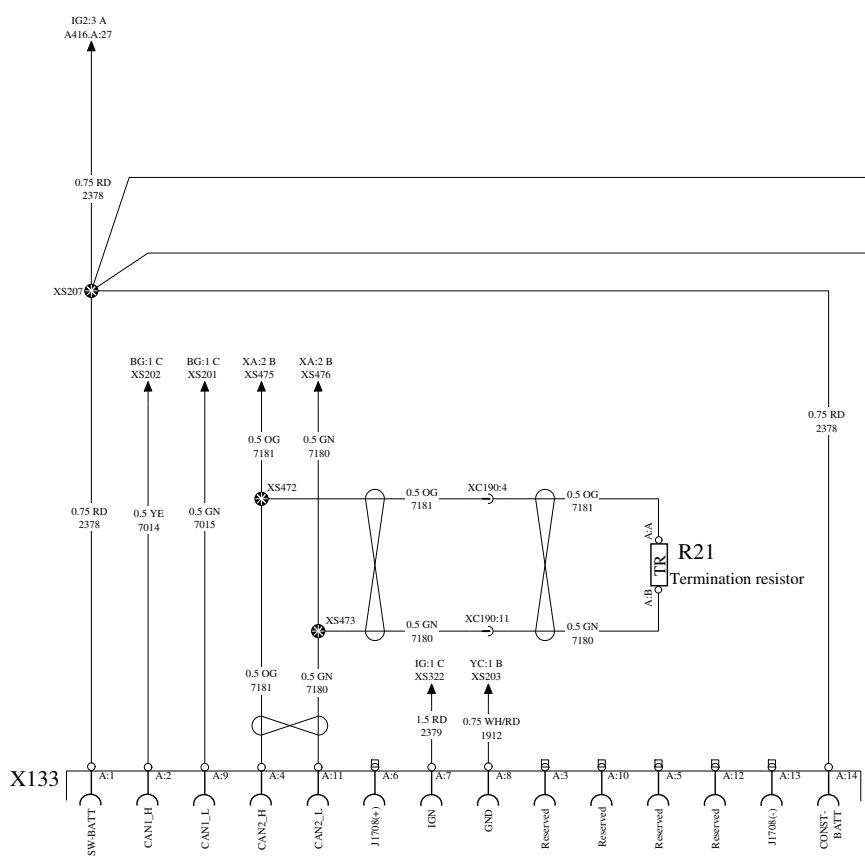

RP1226 #1

RP1226 #2



Document title WIRING DIAGRAM, TEA2+ DIESEL	Document No	Issue	Volume	Page
	24798720	01	1(1)	18 (125)
Legal Owner Volvo Truck Corporation				

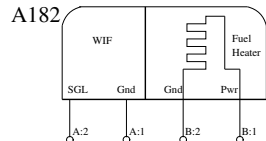

SEE SHEET AA1 FOR MATING CONNECTOR

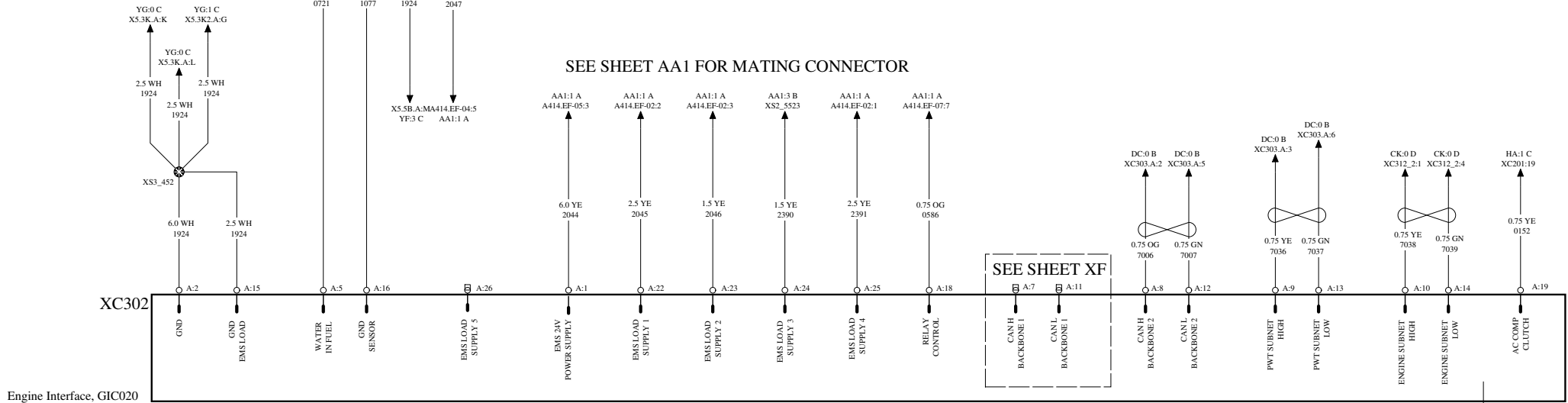

Engine Interface, GIC020



Document title
WIRING DIAGRAM, TEA2+ DIESEL

Legal owner
Volvo Truck Corporation

Document No
24798720

Issue
01

Volume
1(1)

Page
19 (125)

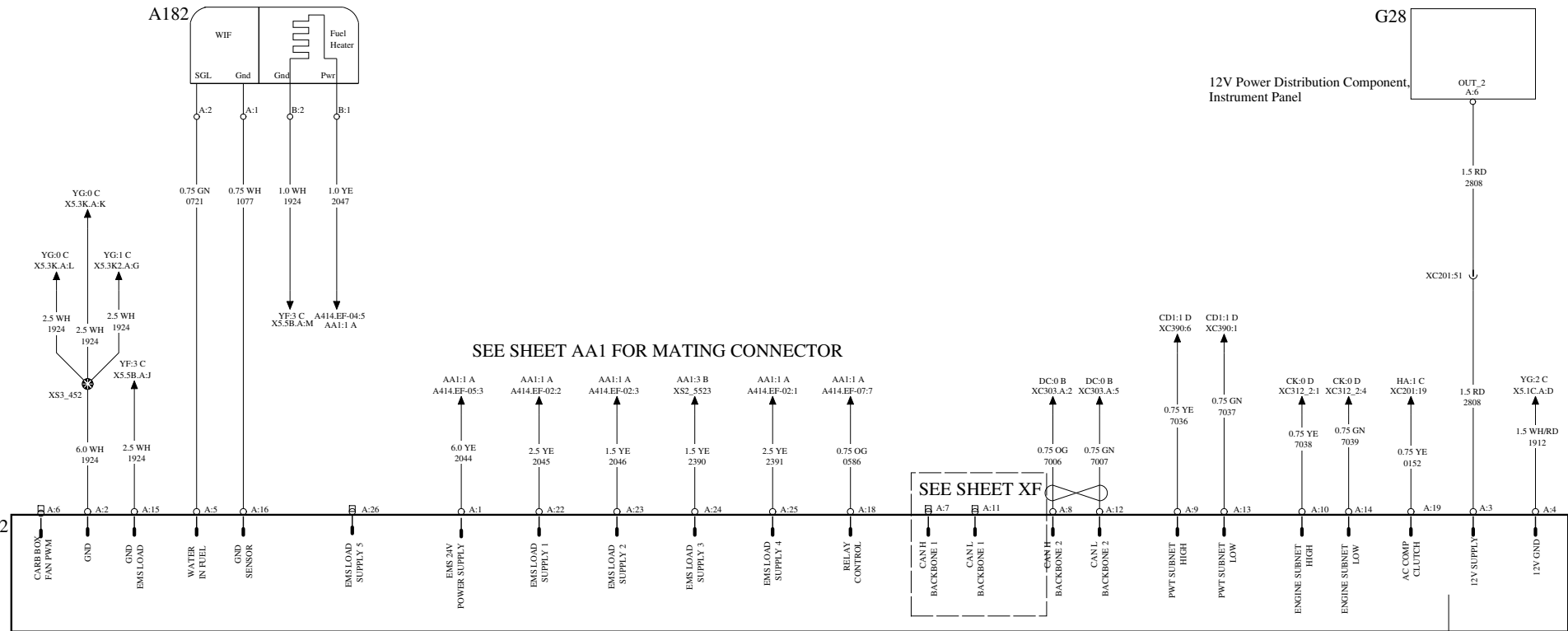

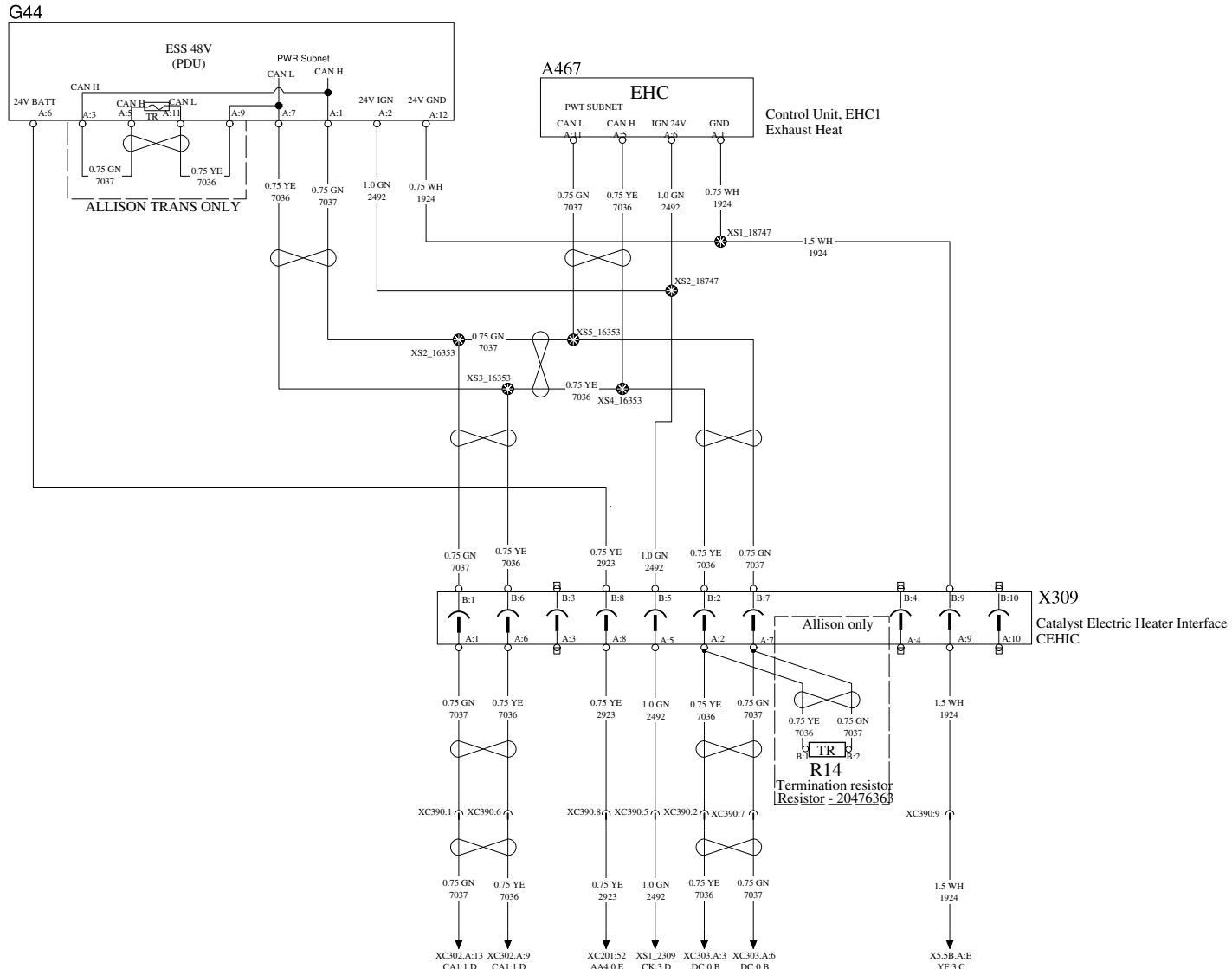

Document title
WIRING DIAGRAM, TEA2+ DIESEL

Legal owner
Volvo Truck Corporation

Document No

24798720

Issue

01

Volume

1(1)

Page

21 (125)

AFTERTREATMENT SYSTEM

EPA24

WIRING DIAGRAM CK

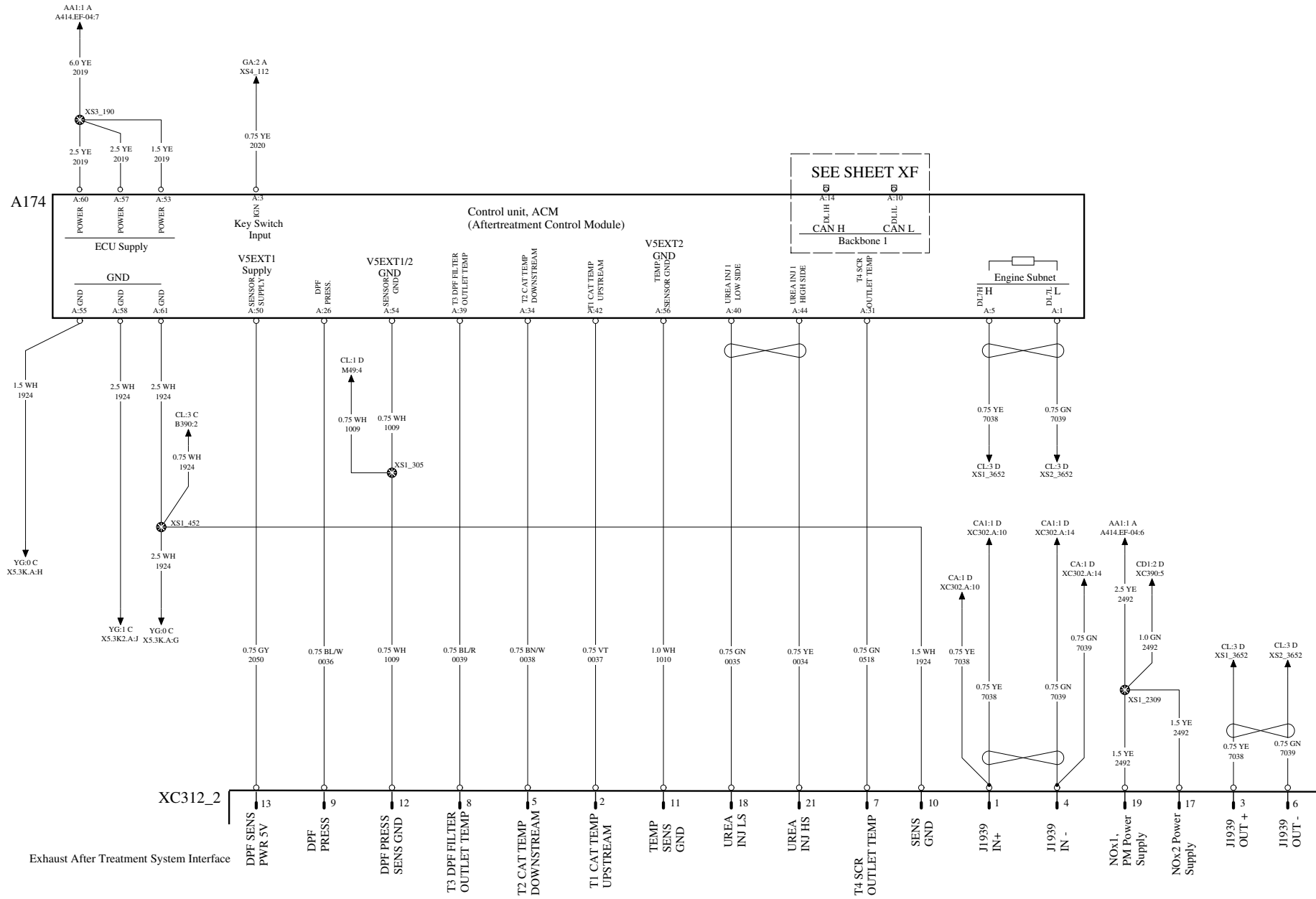

VOLVO

Document title
WIRING DIAGRAM, TEA2+ DIESEL
Legal Owner
Volvo Truck Corporation

Document No
24798720

Issue	Volume	Page
01	1(1)	22 (125)

A174

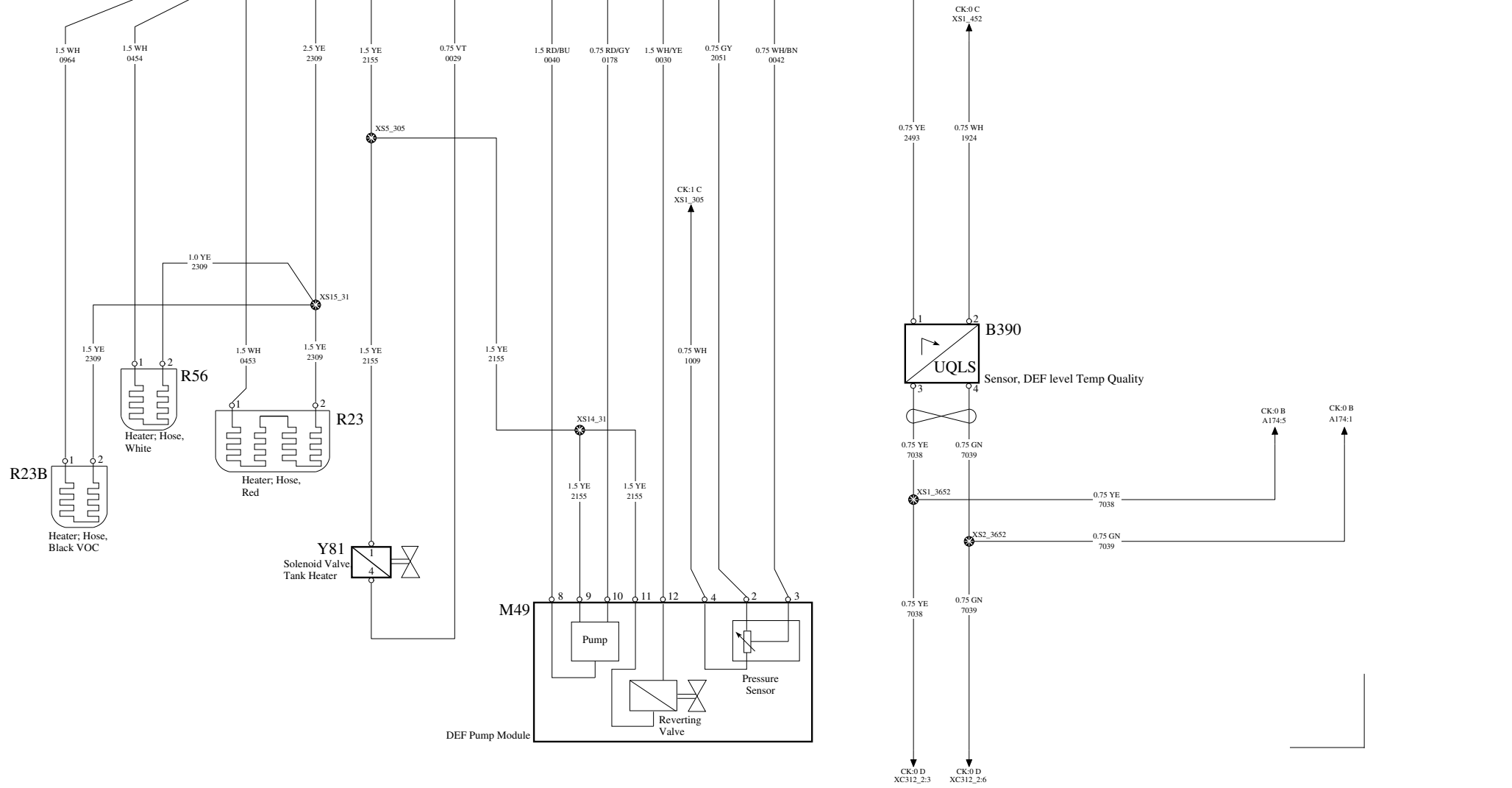
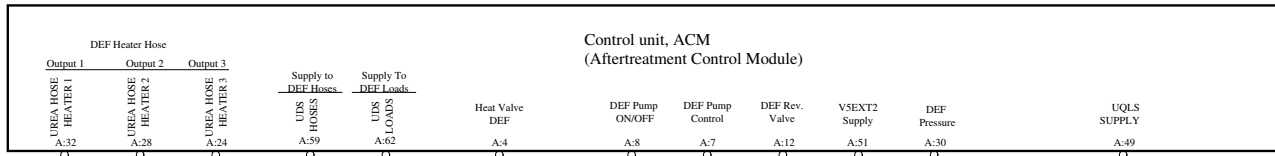

TRANSMISSION

I-SHIFT

WIRING DIAGRAM DC

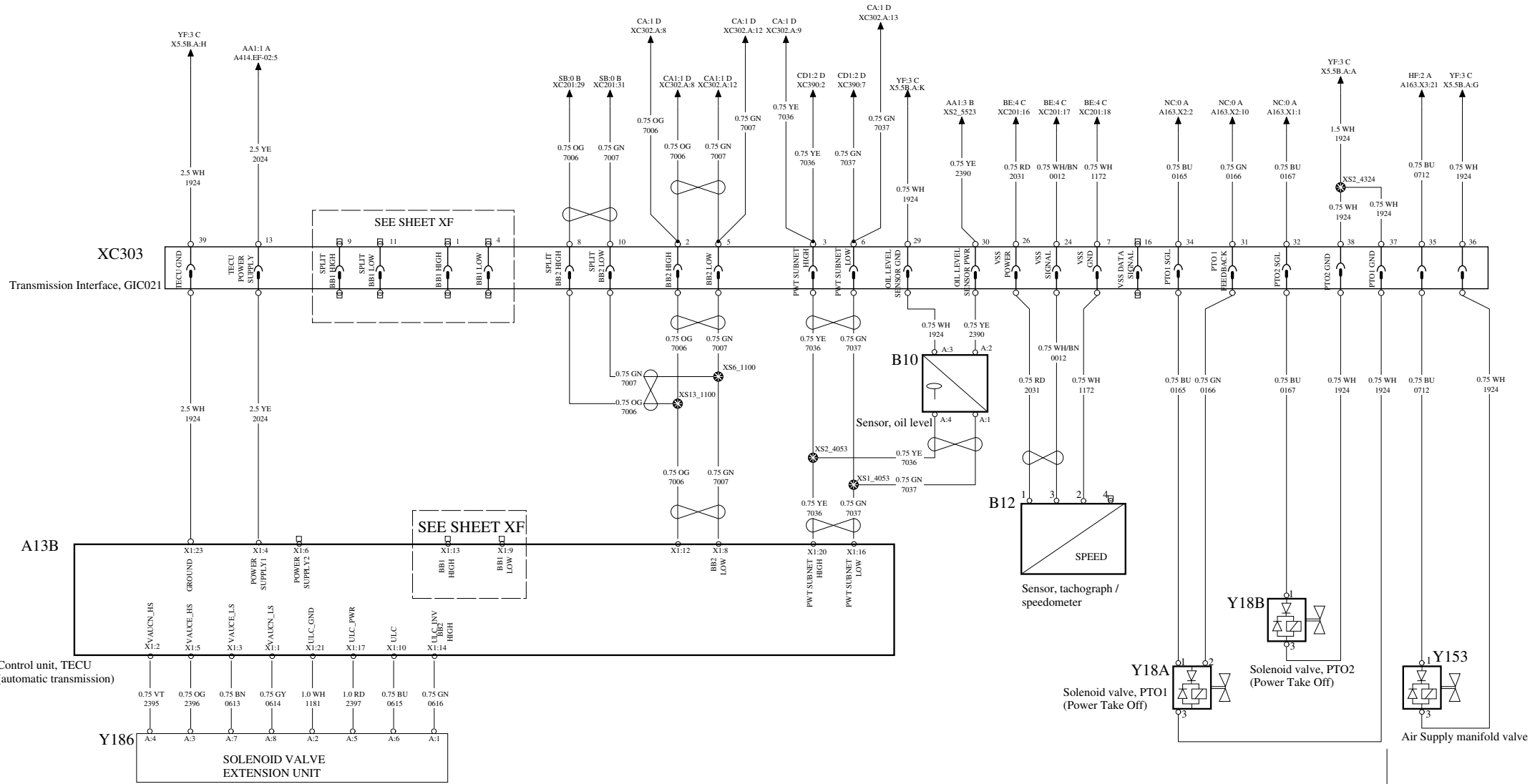

VOLVO

Document title
WIRING DIAGRAM, TEA2+ DIESEL

Legal Owner
Volvo Truck Corporation

Document No

24798720

Issue

01

Volume

1(1)

Page

24 (125)

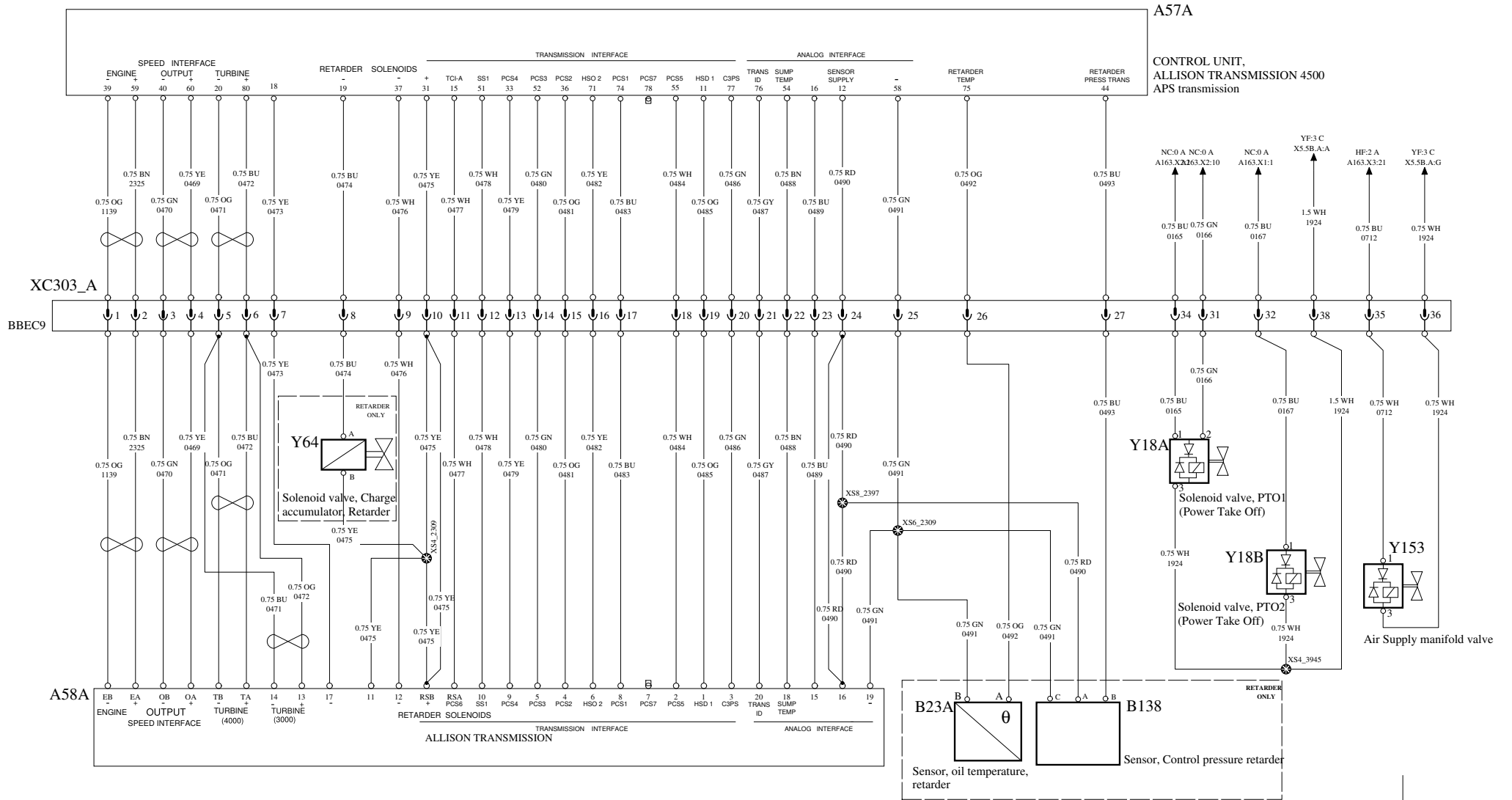

EBS HIGHWAY

CONTROL UNIT

WIRING DIAGRAM EE

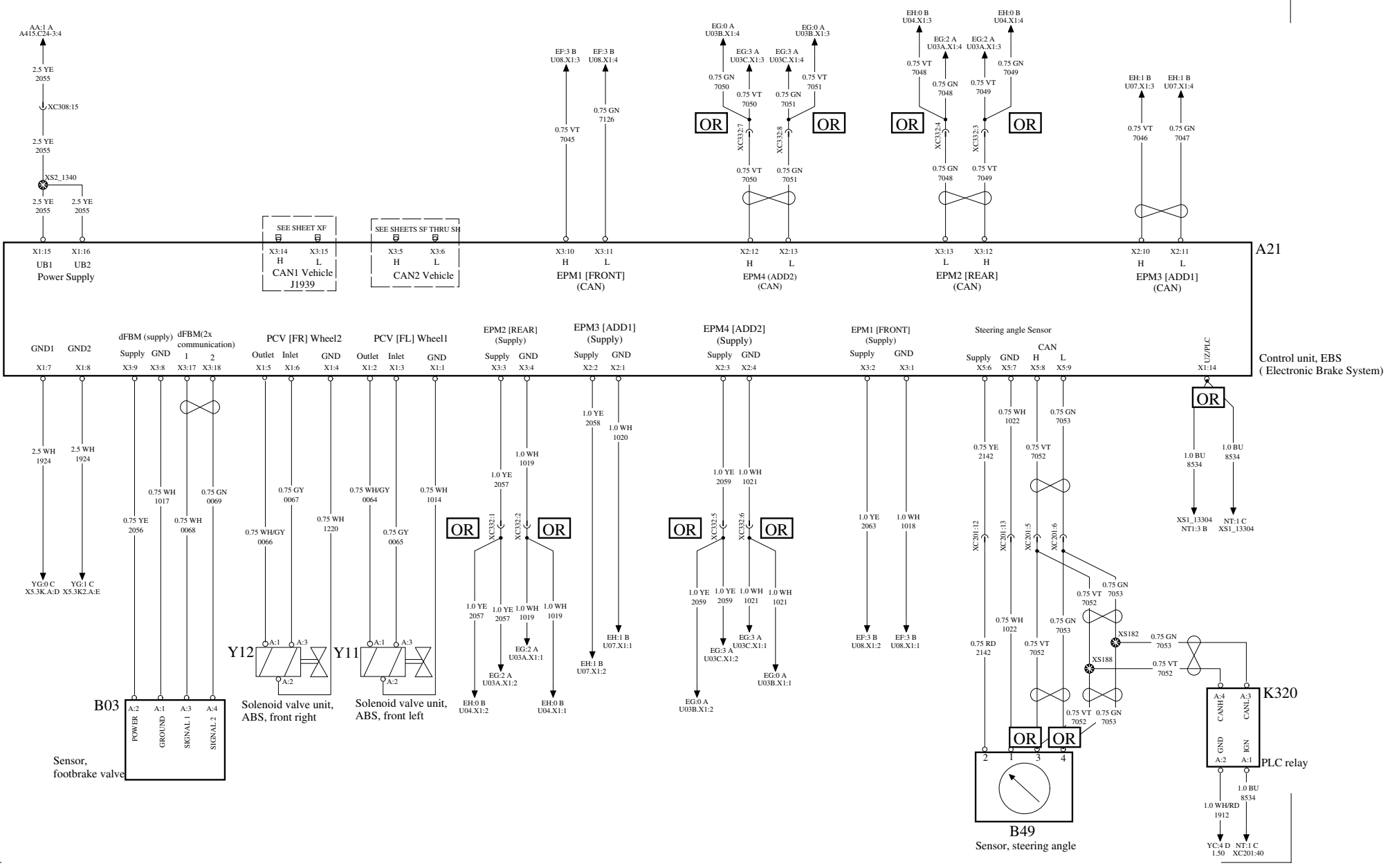

Document title
WIRING DIAGRAM, TEA2+ DIESEL

Legal Owner
Volvo Truck Corporation

Document No
24798720

Issue	Volume	Page
01	1(1)	26 (125)

EBS FRONT AXLE

MODULATOR

WIRING DIAGRAM EF

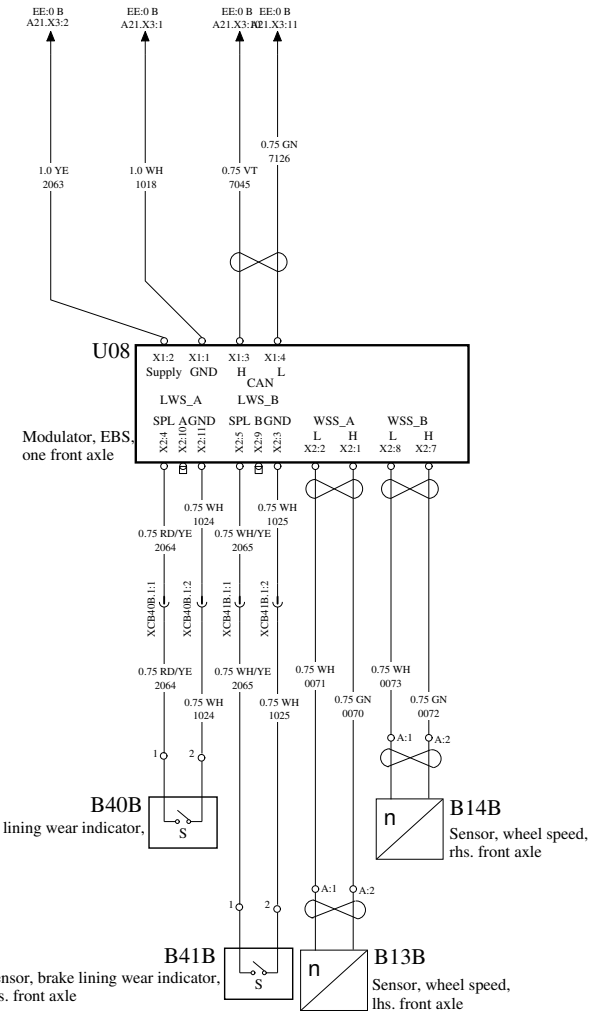
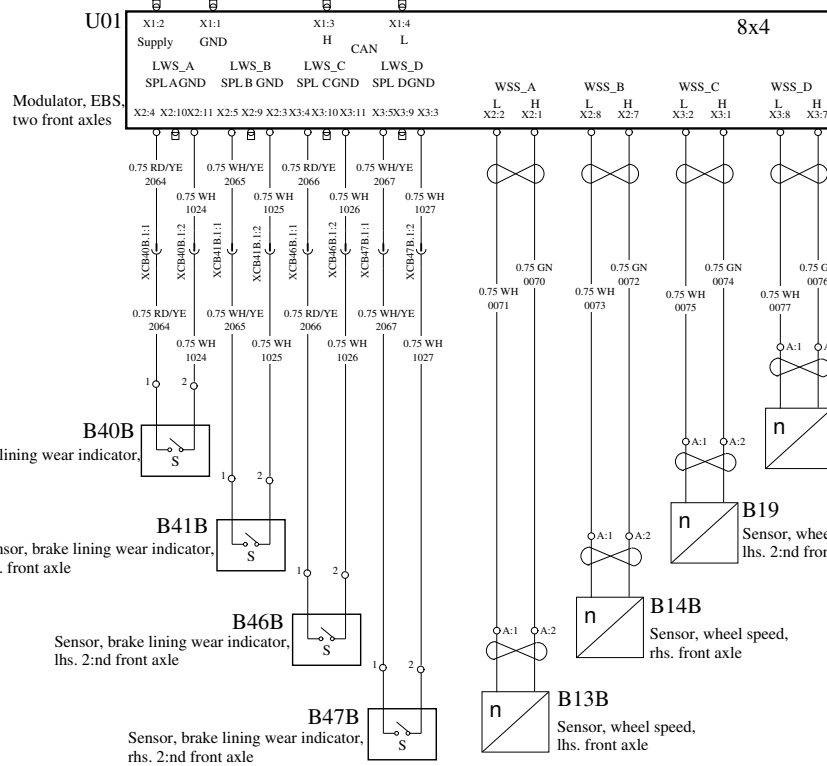

EBS 6S6M HIGHWAY

REAR AXLE MODULATOR

WIRING DIAGRAM EG

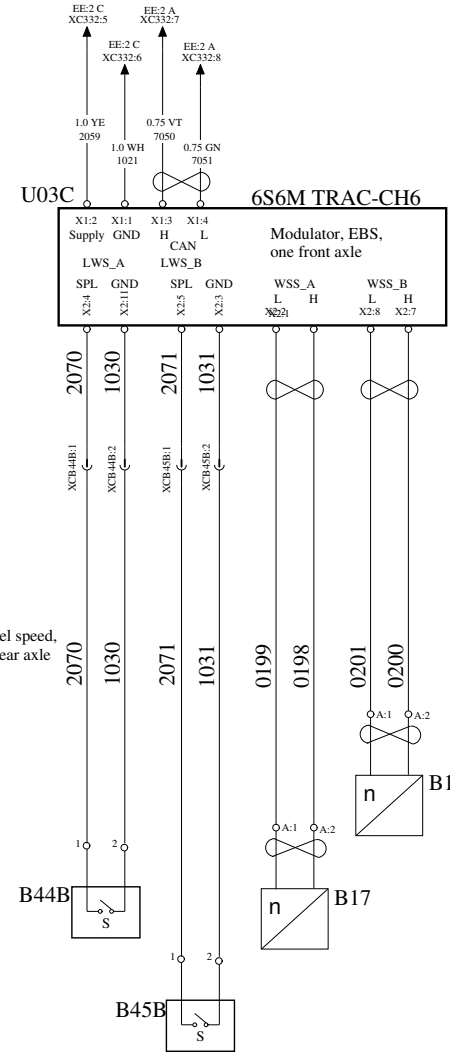
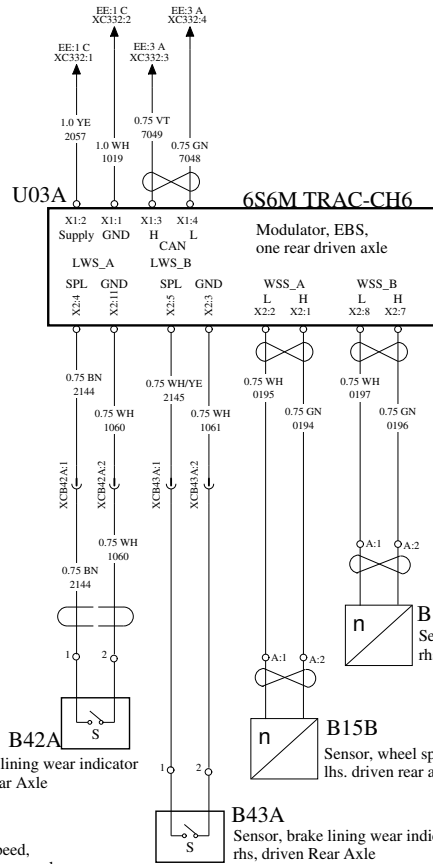
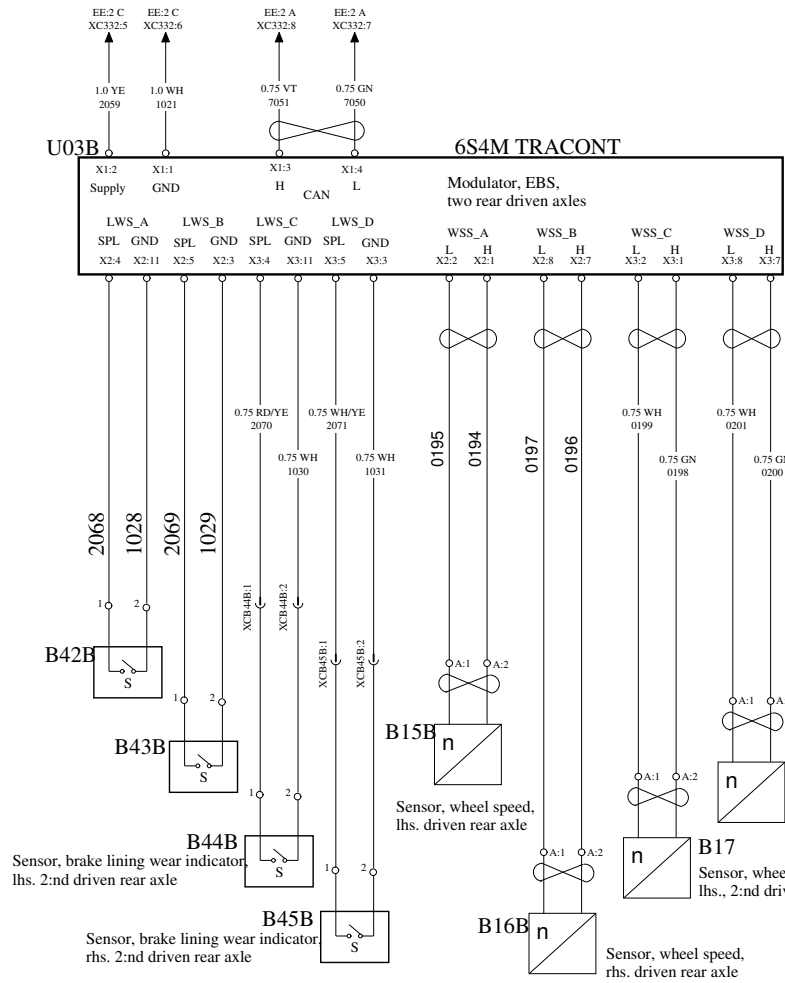

Driven Axle - 4x2 / 6x2

Driven Axles - 6x4 / 8x4 / 8x6



EBS OPTIONAL

8x2 TRIDEM MODULATORS

WIRING DIAGRAM EH

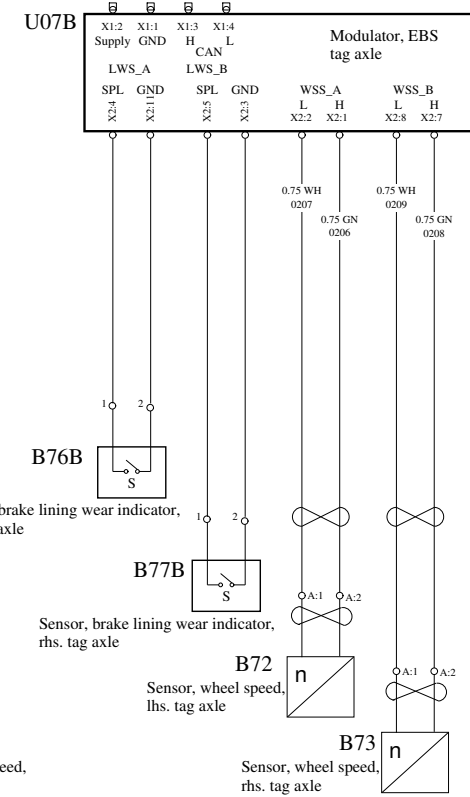
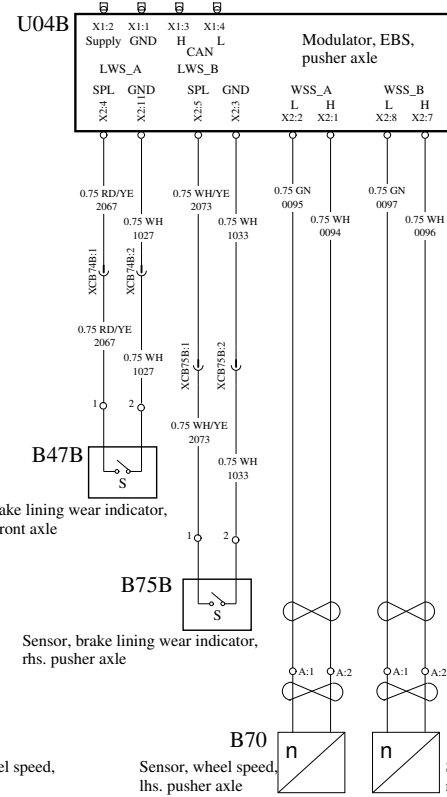
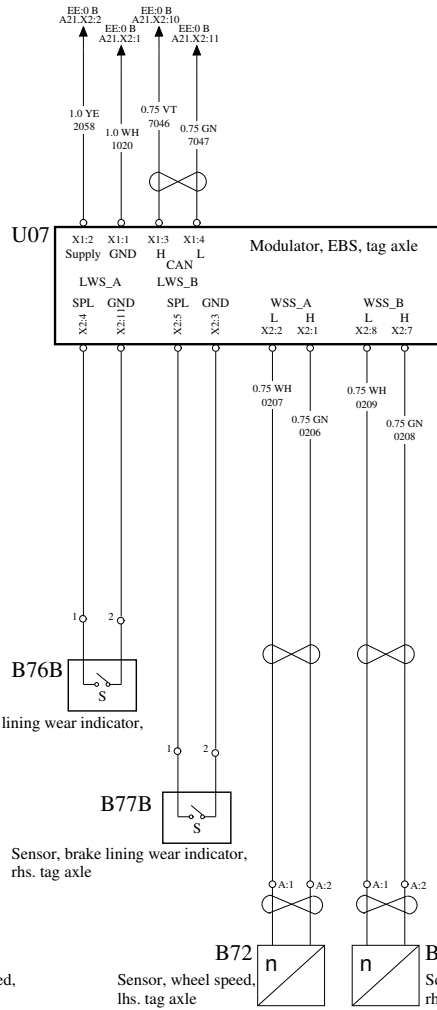
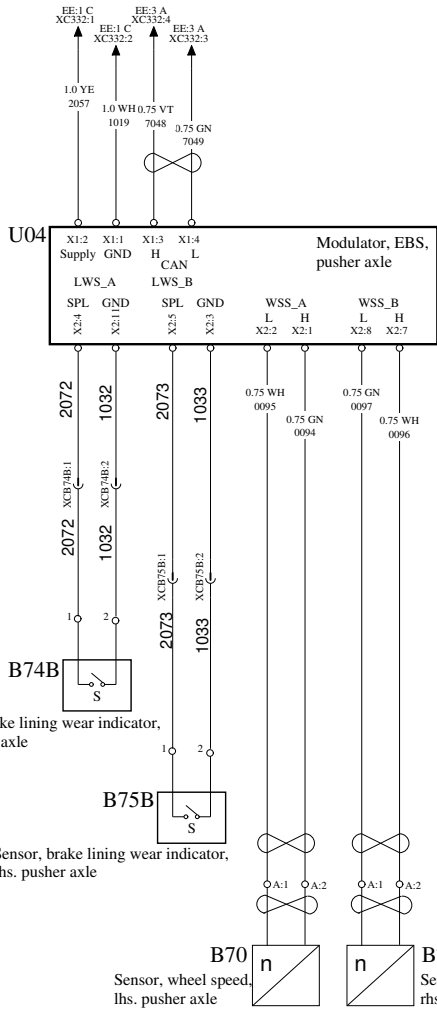

Pusher Axle



EBS TRAILER

MODULATOR

WIRING DIAGRAM EI

A21

TRACTOR

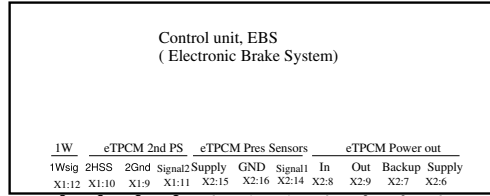

A21

POGO STICK MNT

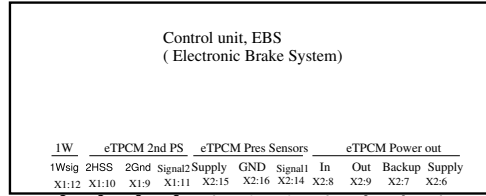

A21B

VOCATIONAL TRACTOR

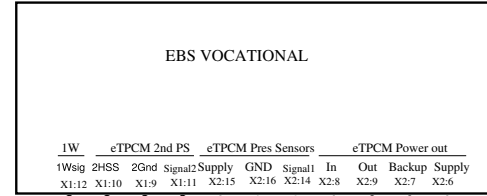

A21B

VOCATIONAL POGO & RIGID

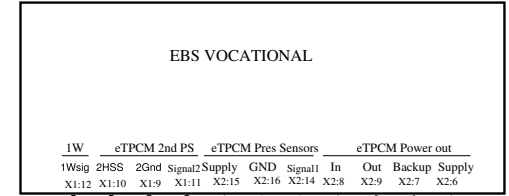

U05C

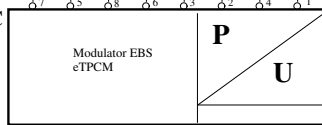

Modulator, EBS, trailer

U05C

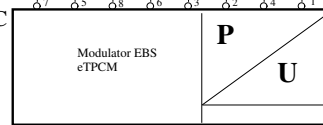

Modulator, EBS, trailer

U05C

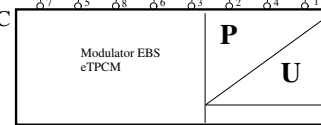

Modulator, EBS, trailer

U05D

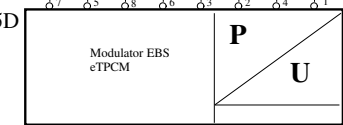

Document title
WIRING DIAGRAM, TEA2+ DIESEL

Legal Owner
Volvo Truck Corporation

Document No

24798720

Issue

01

Volume

1(1)

Page

30 (125)

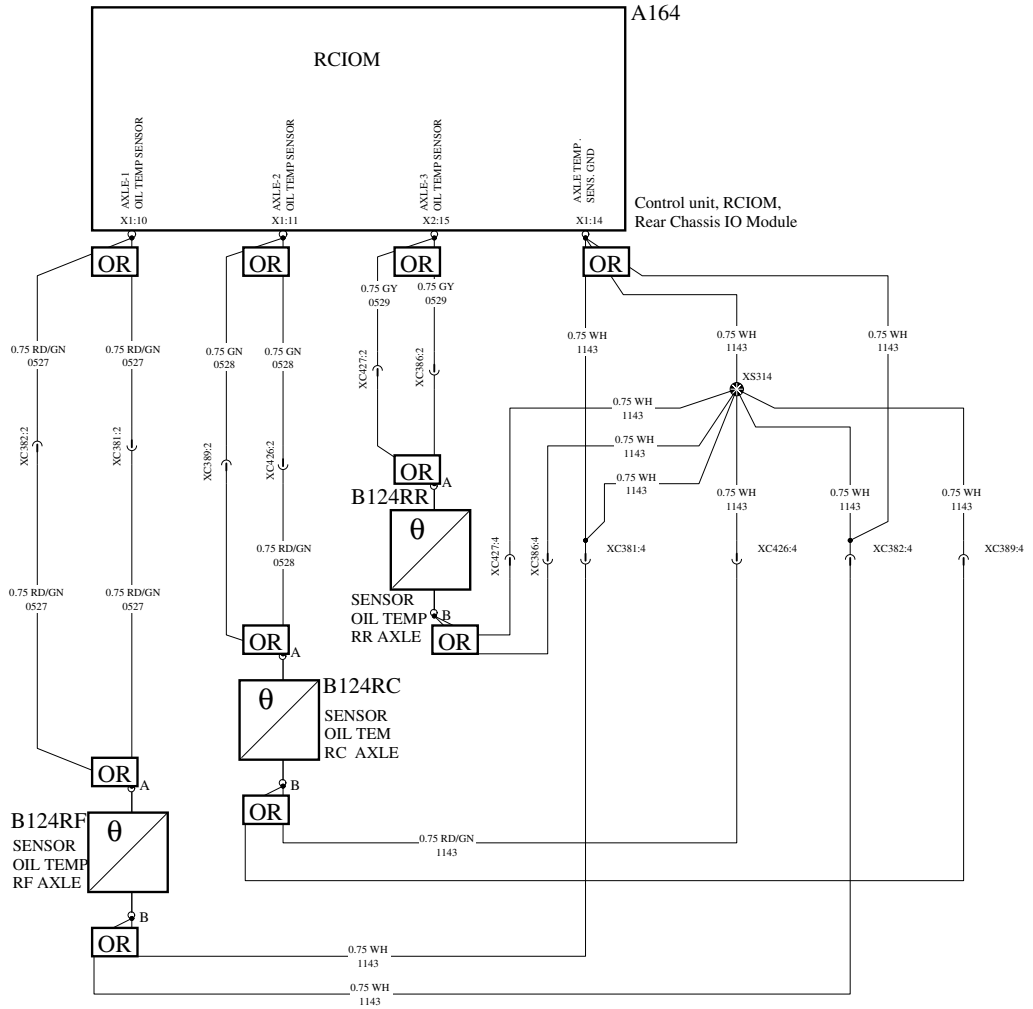
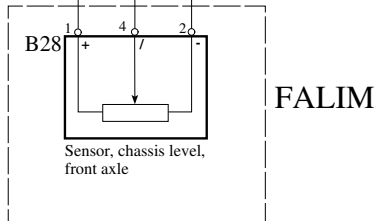
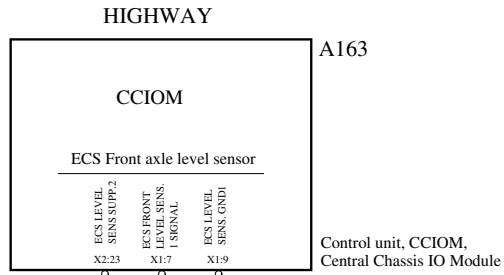

A164

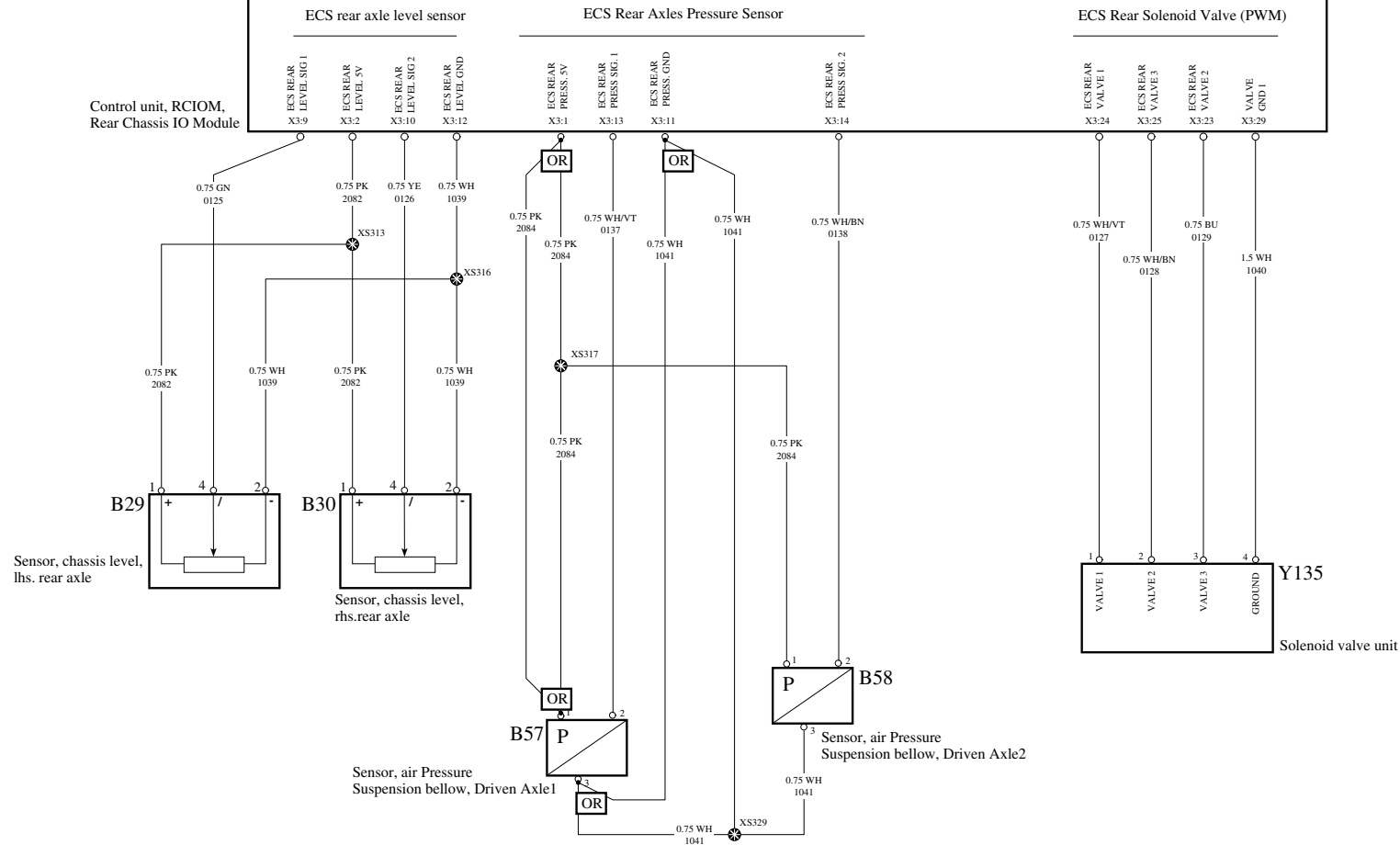

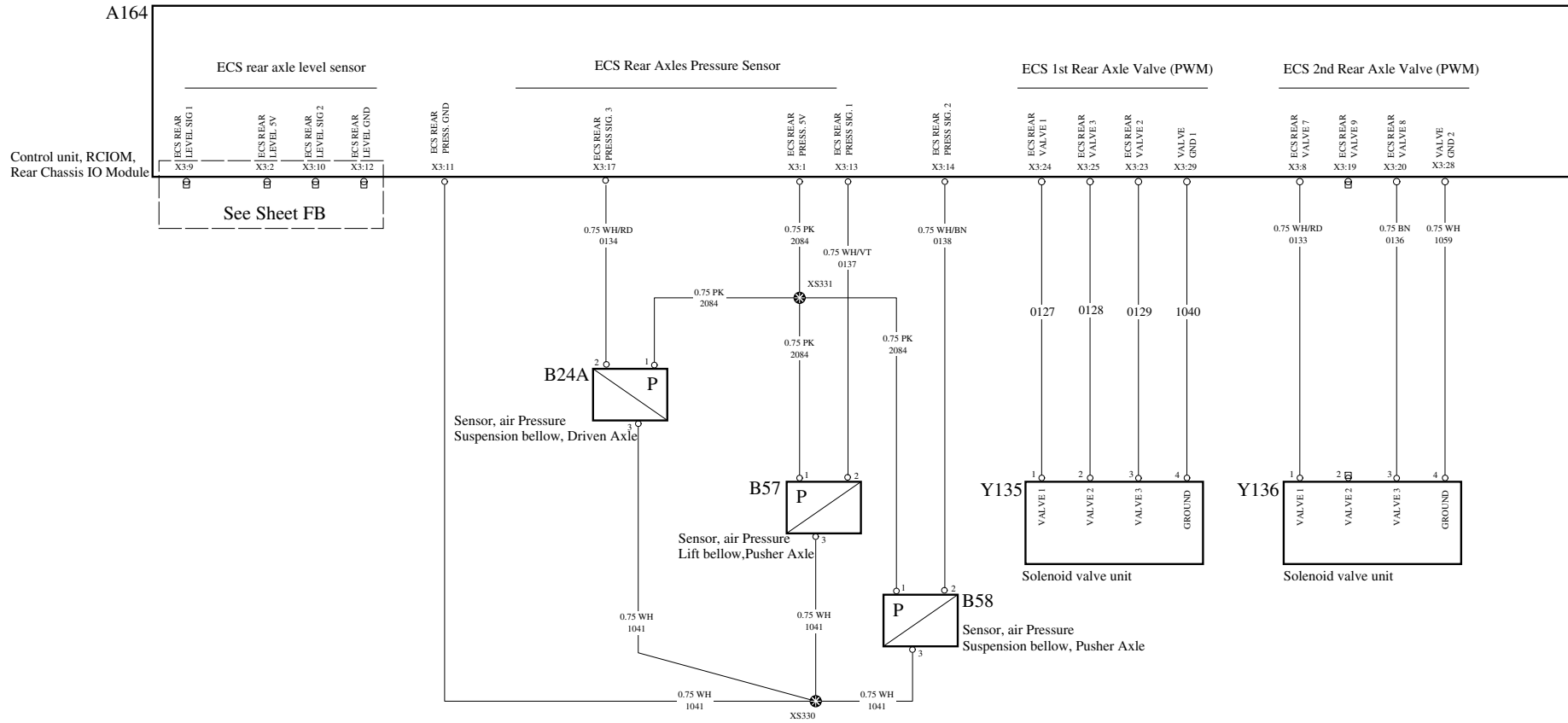

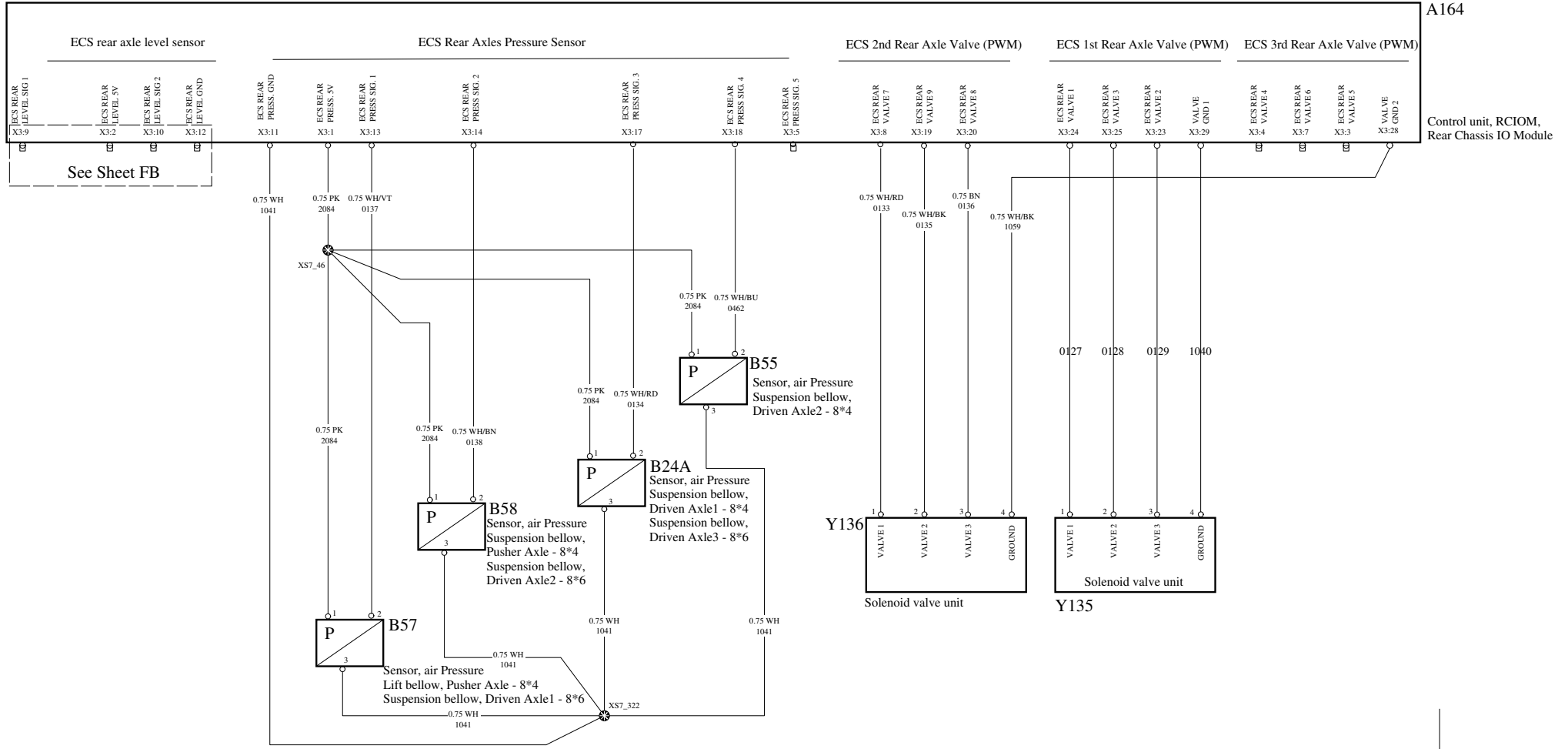

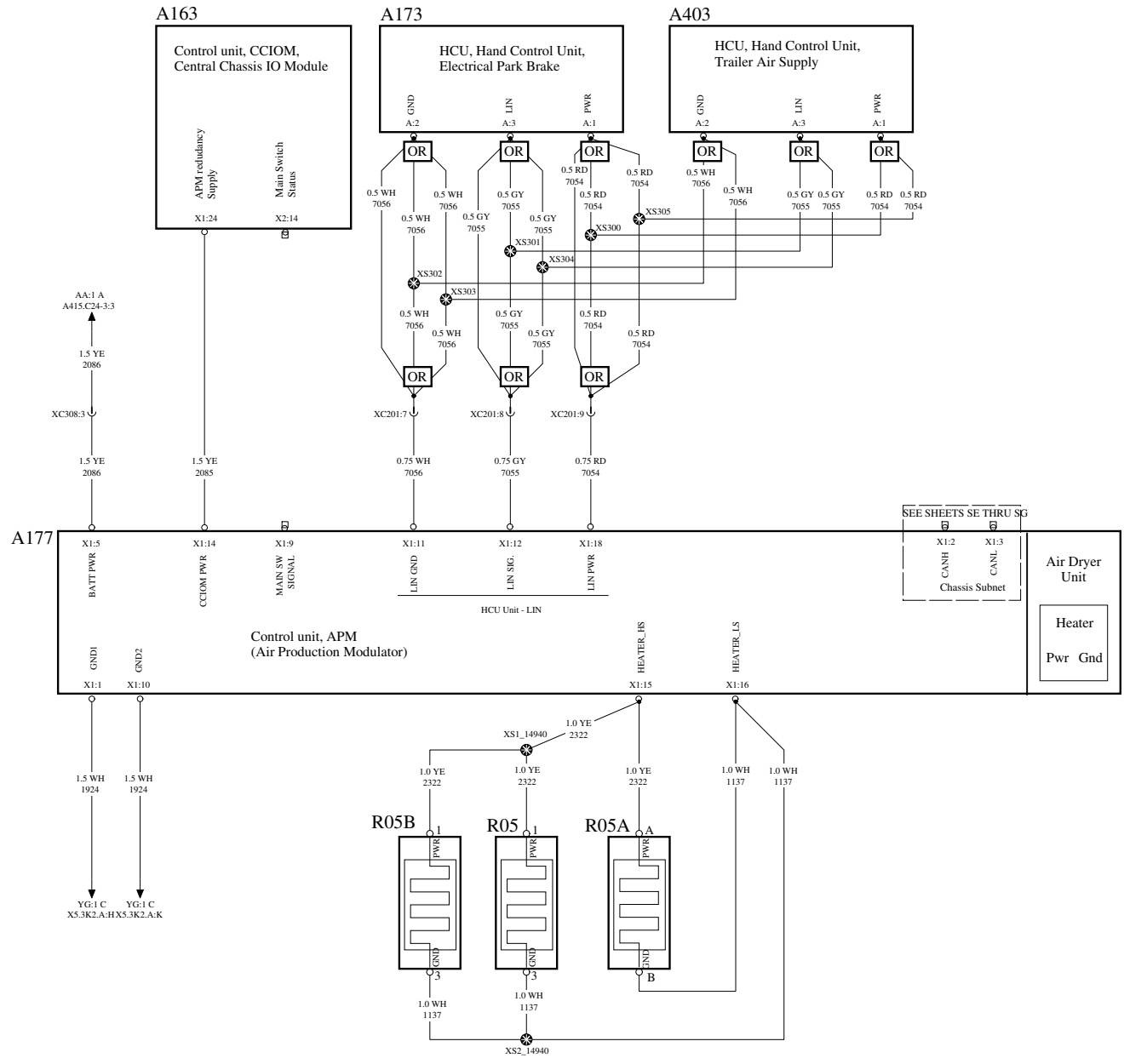

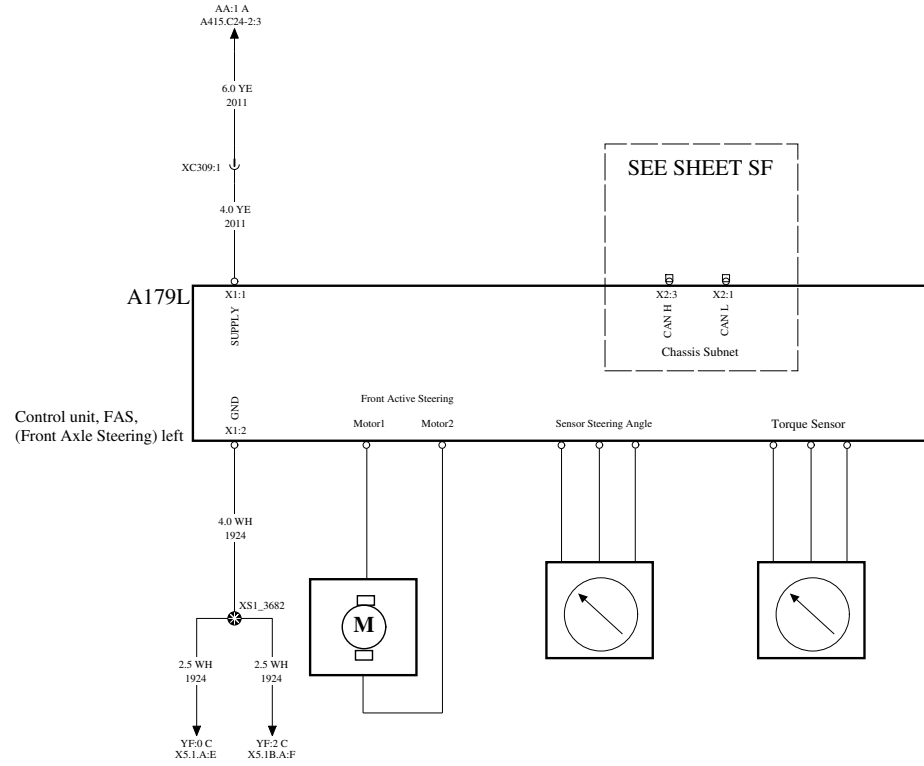

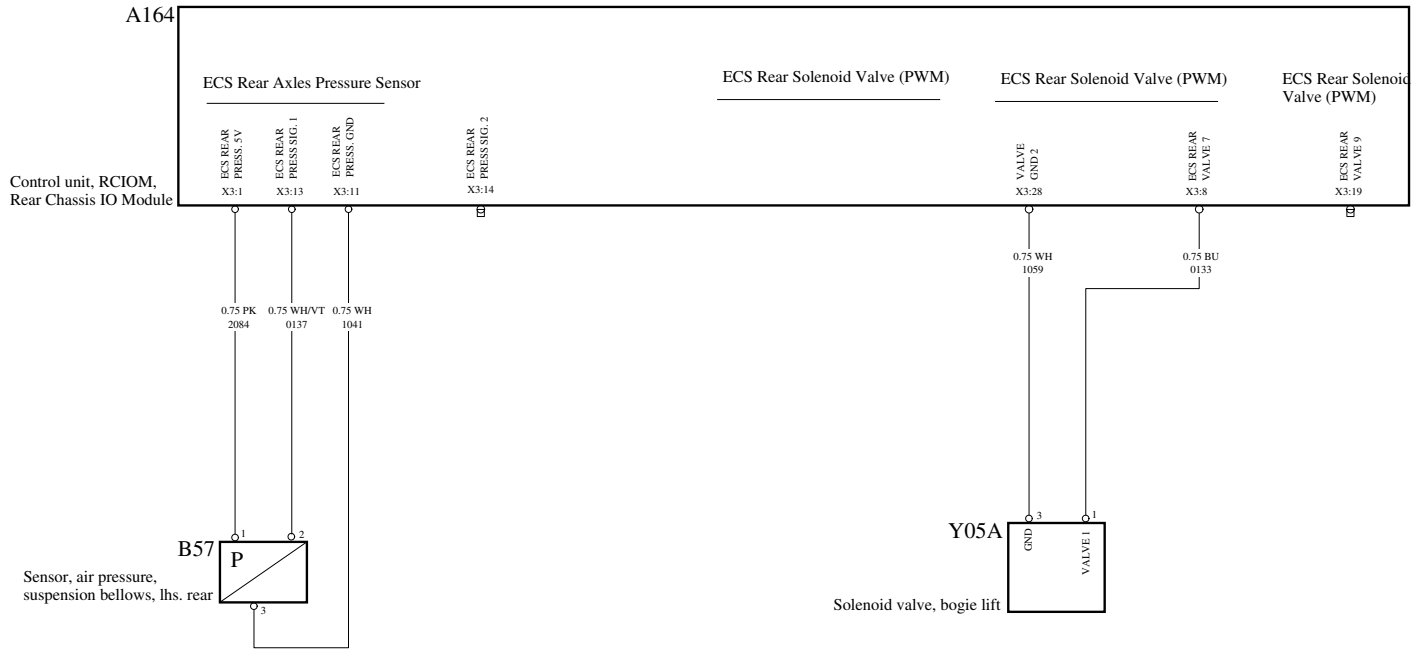

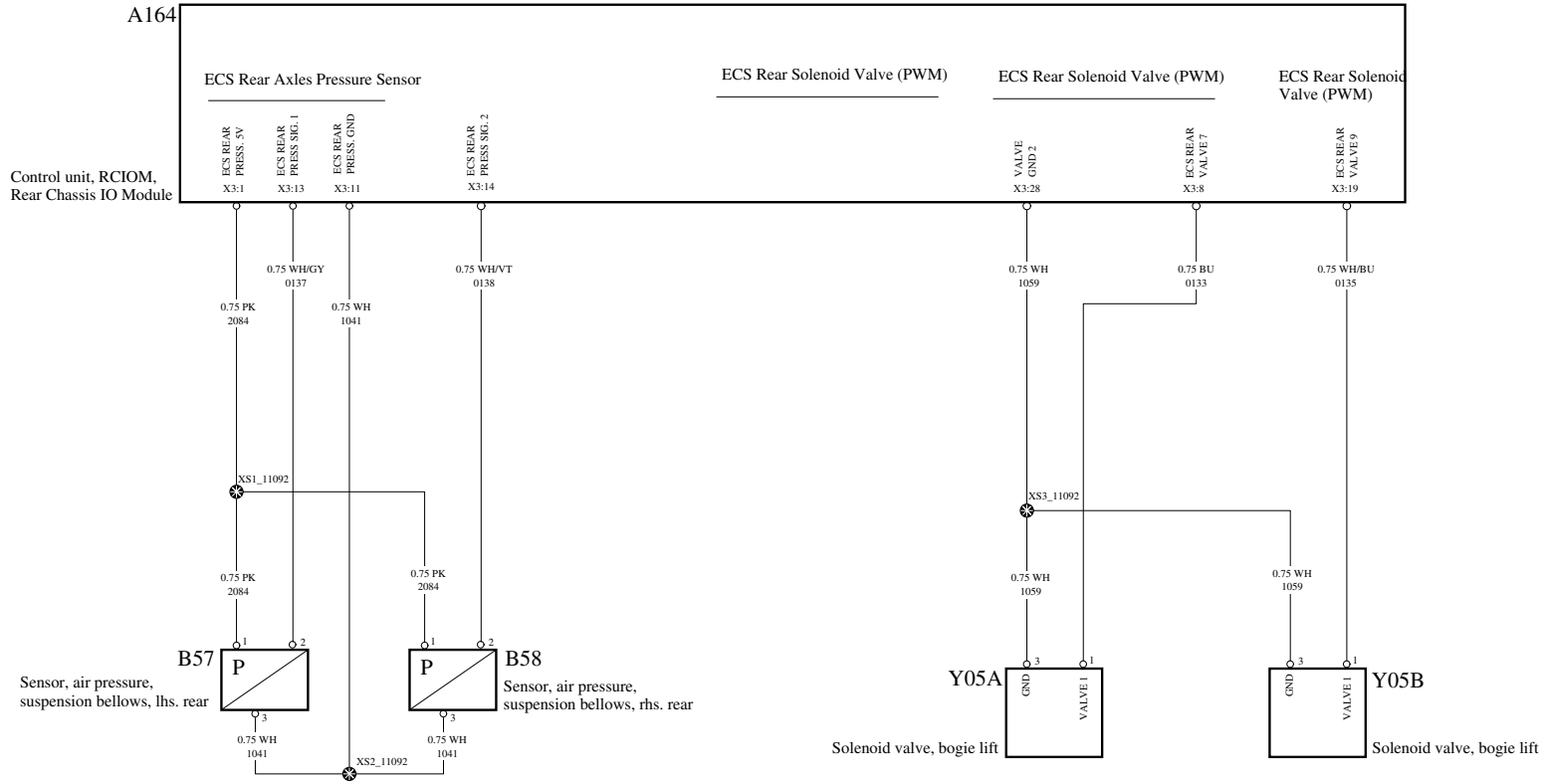

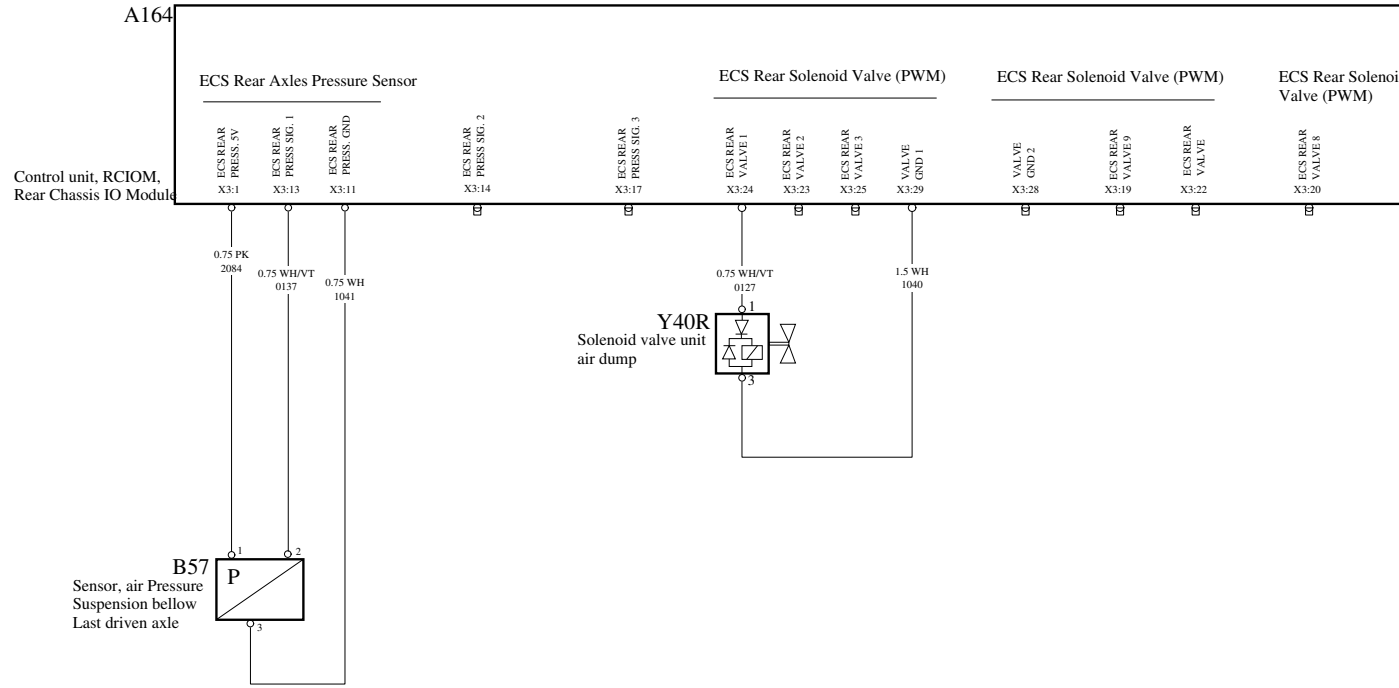

EXTERIOR LIGHT, FRONT, LEFT

WIRING DIAGRAM GA

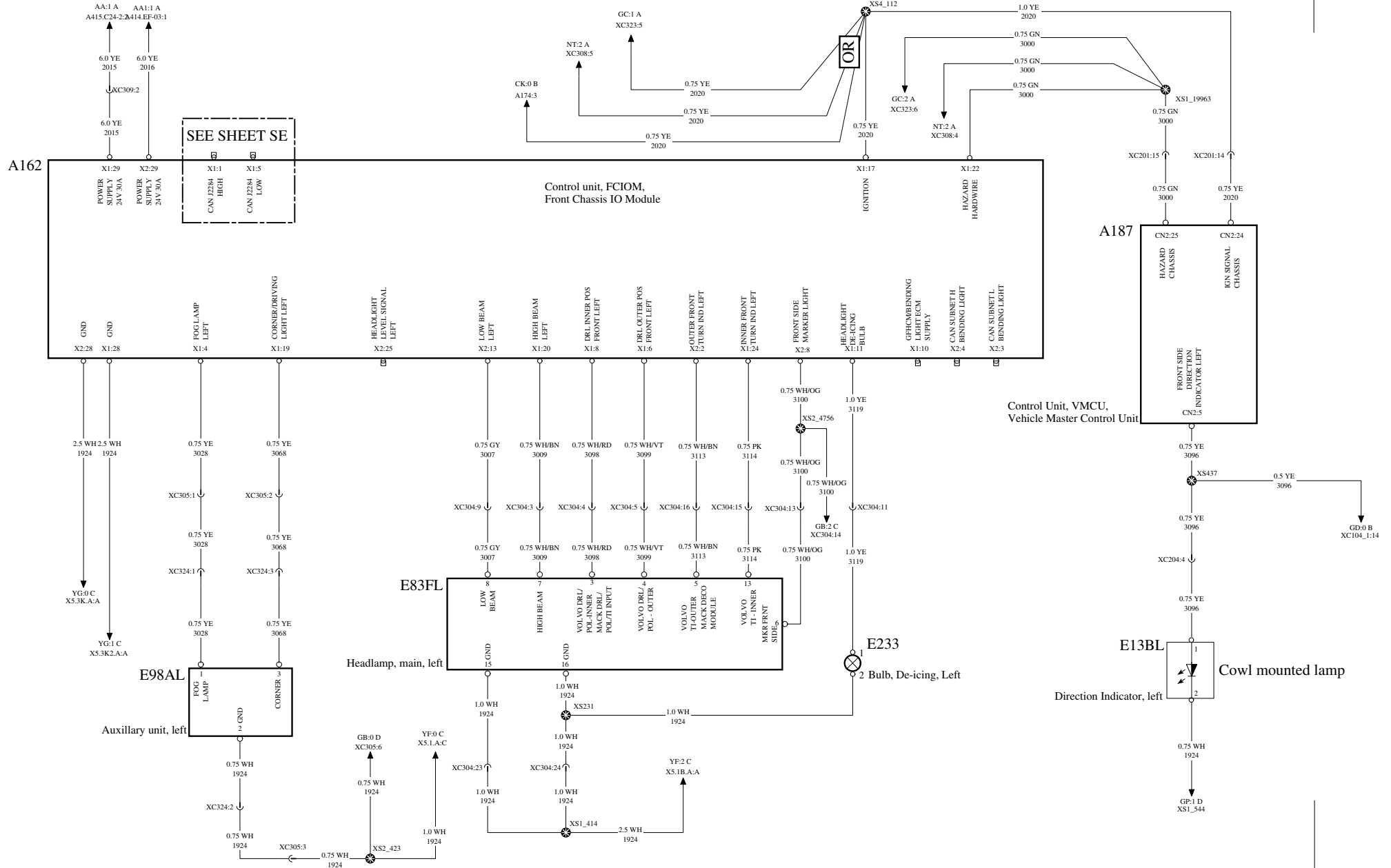

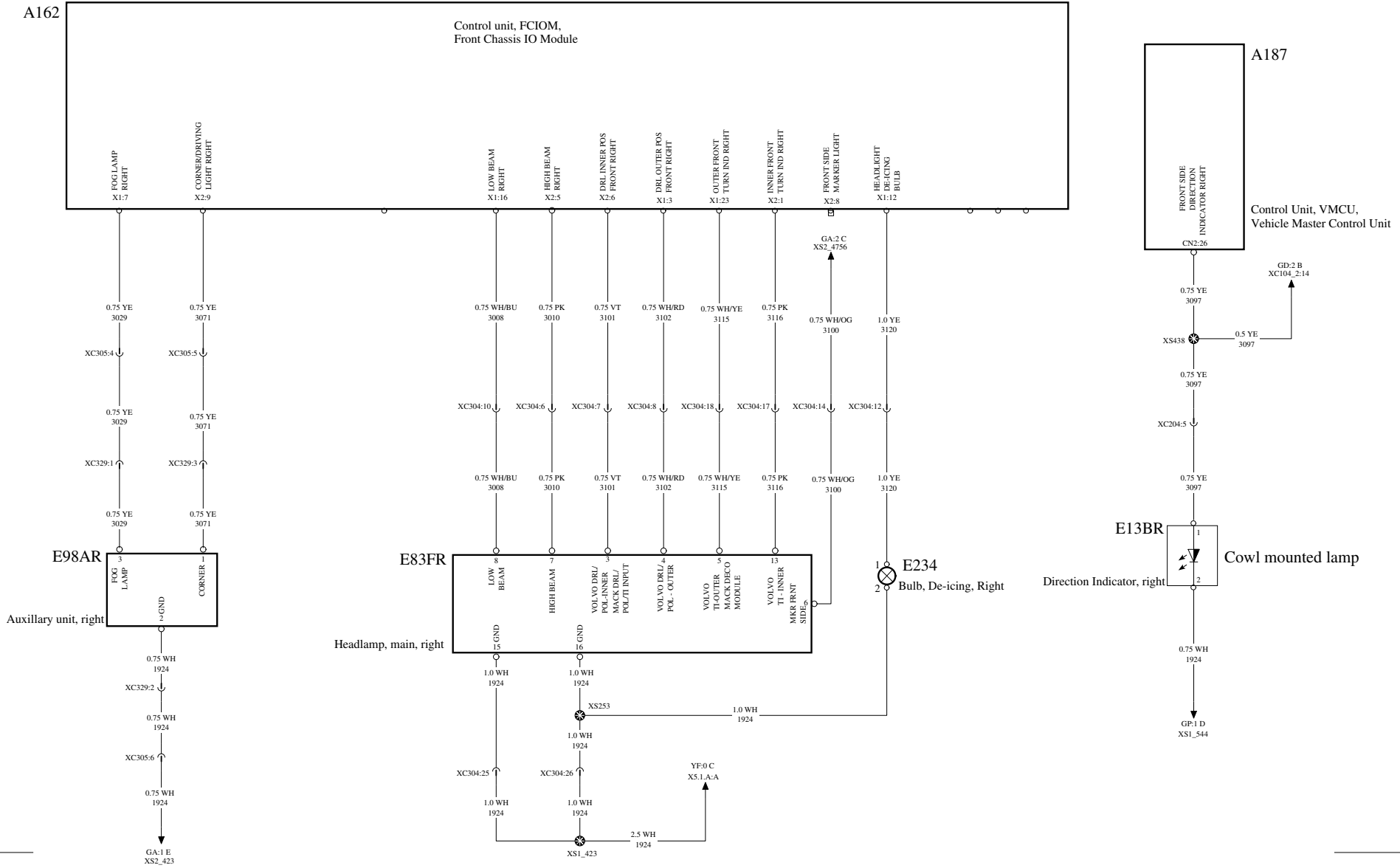

EXTERIOR LIGHTS TL-LED

REAR LIGHT - TL-LED

WIRING DIAGRAM GC

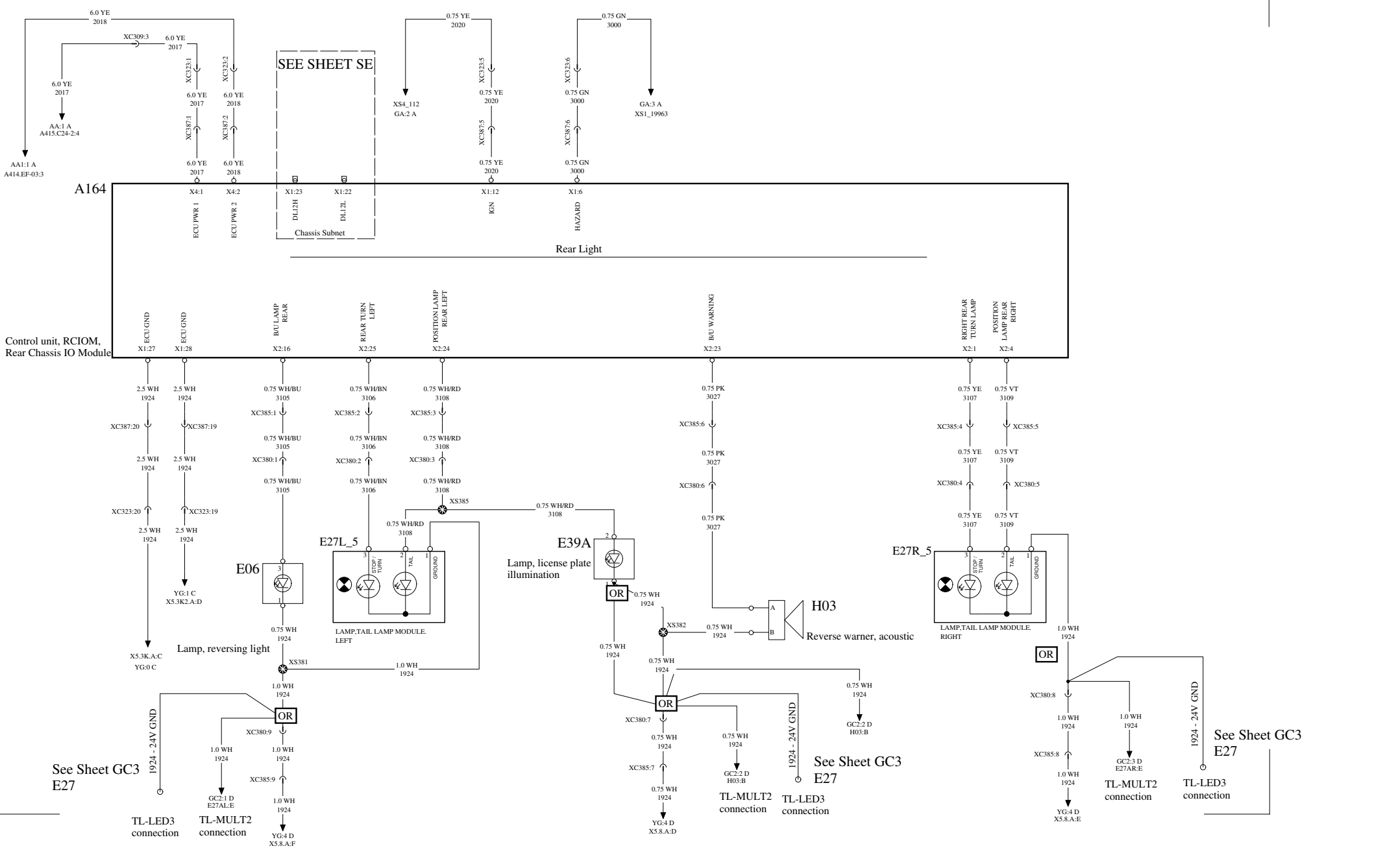

Document title
WIRING DIAGRAM, TEA2+ DIESEL
 Legal Owner
 Volvo Truck Corporation

Document No	Issue	Volume	Page
24798720	01	1(1)	42 (125)

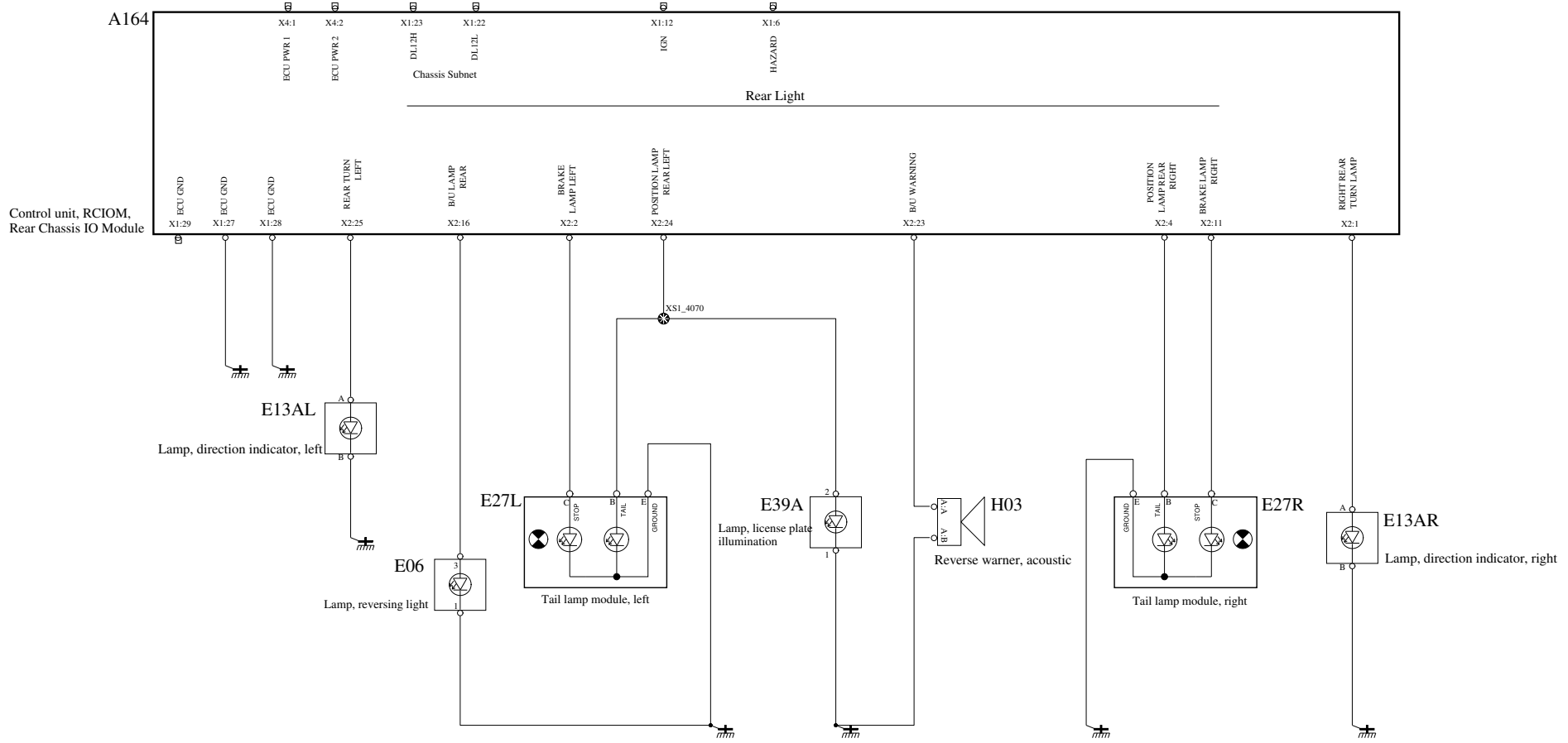

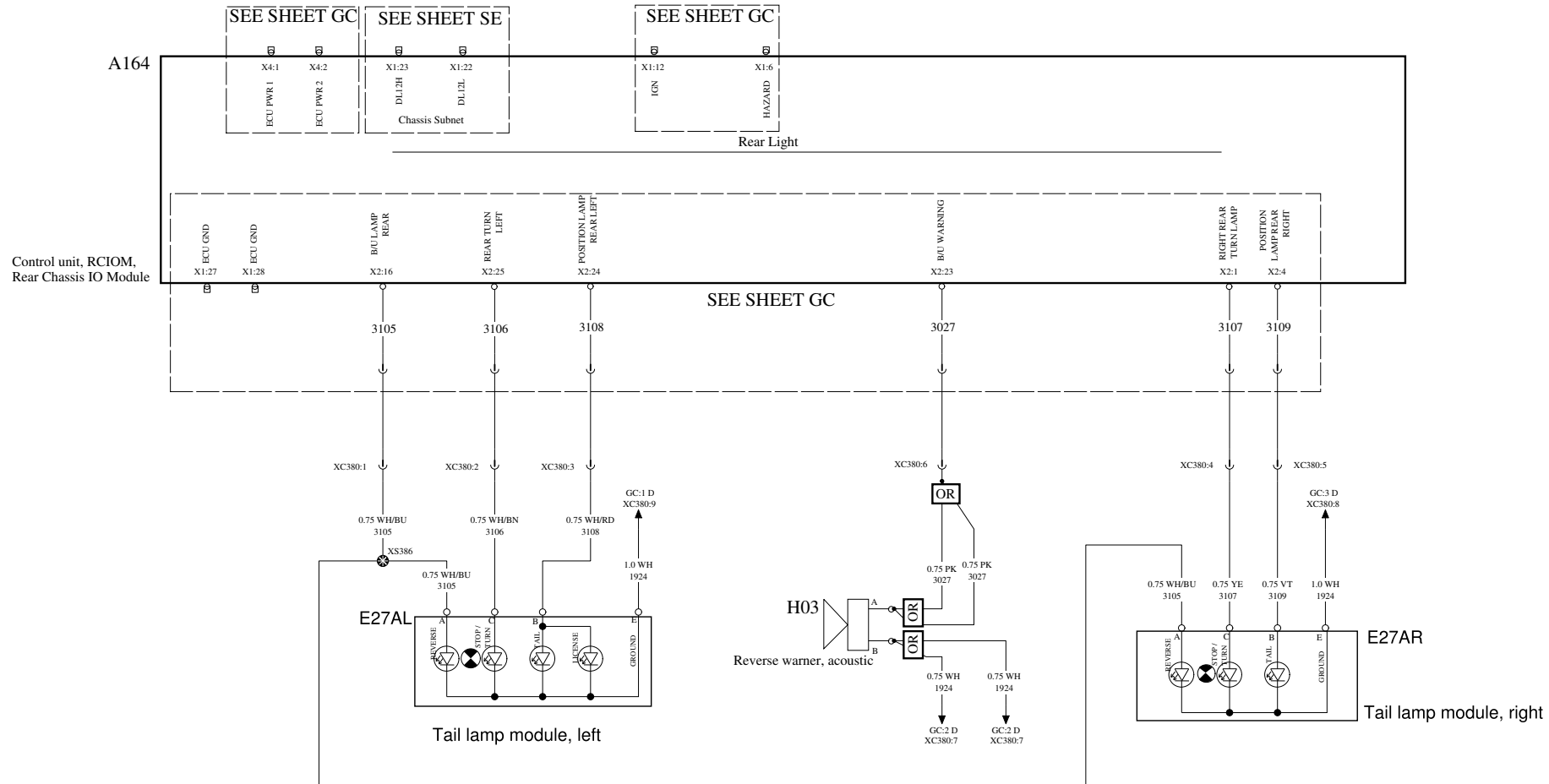

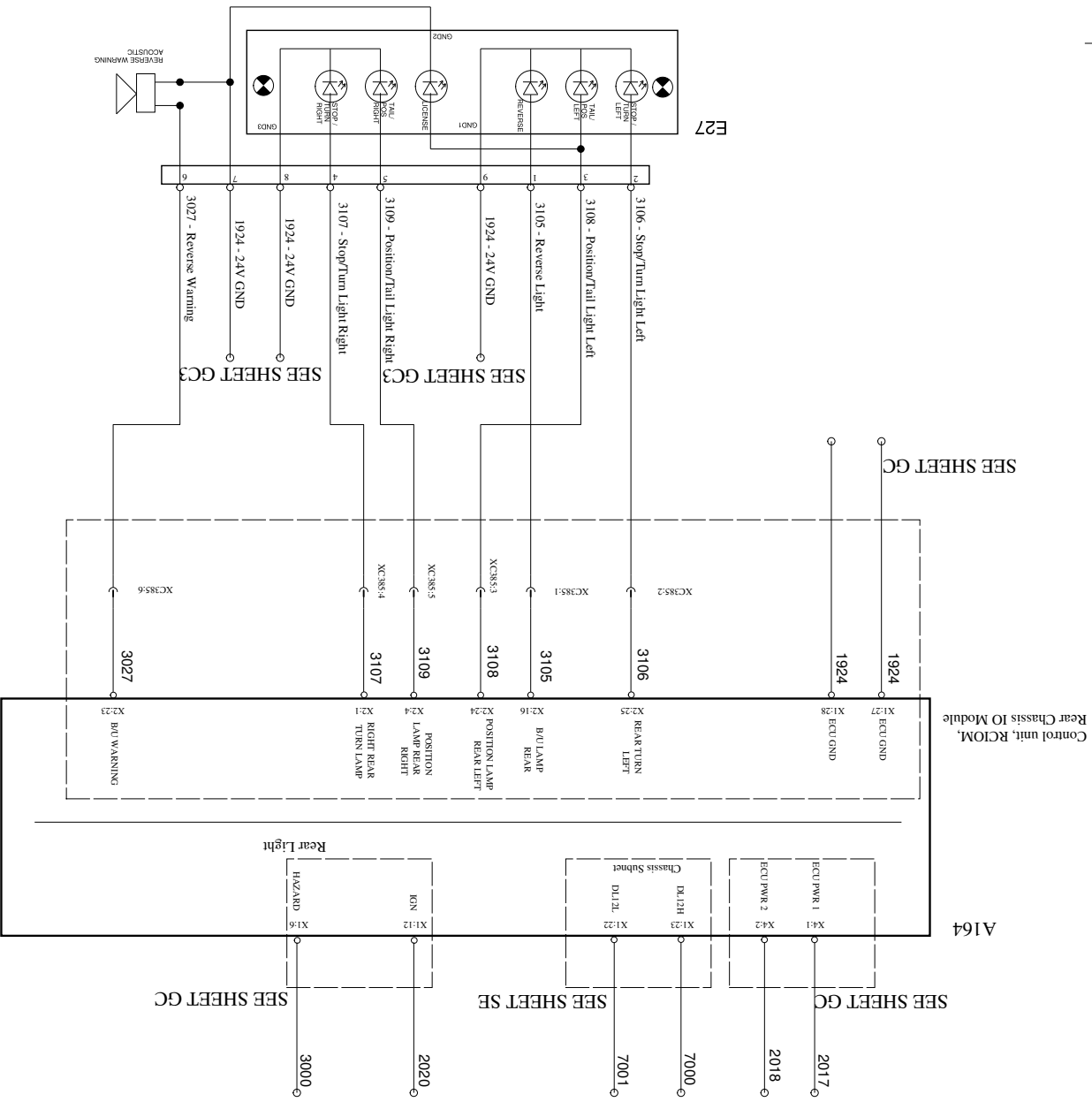

TL-LED3 wiring is part of lamps unit from supplier

WIRING DIAGRAM GC3

REAR LIGHT - TL-LED3

EXTERIOR LIGHTS TL-LED3

EXTERIOR LIGHT, MIRROR

SURROUND & MIRROR GLASS REPEATER LIGHT

WIRING DIAGRAM GD

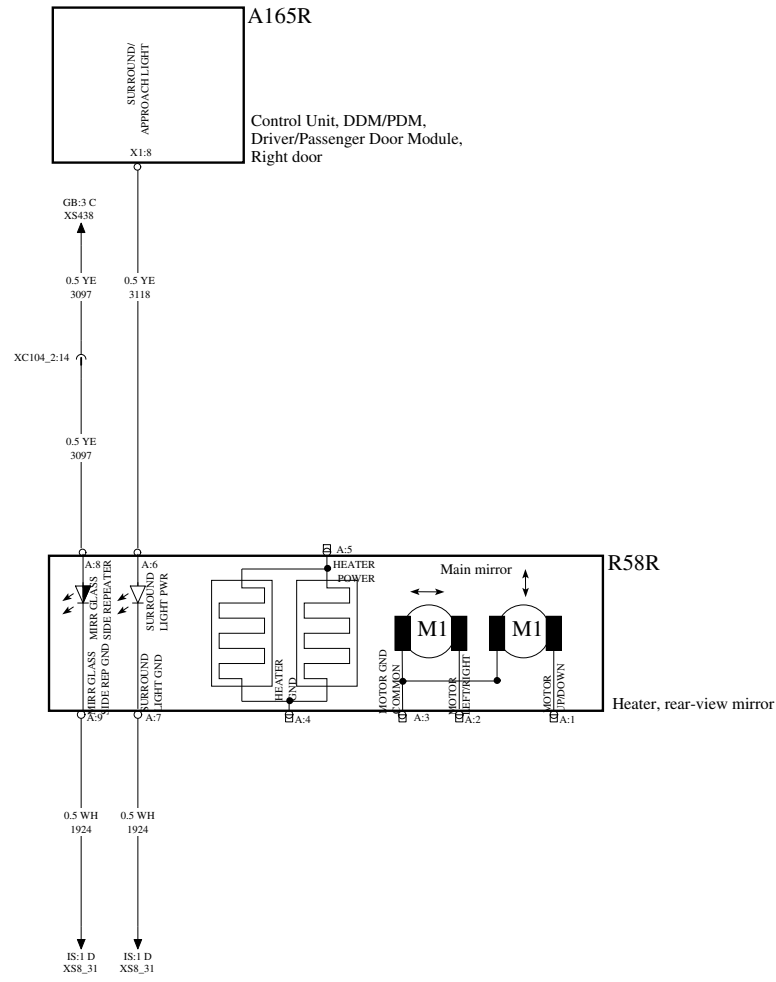
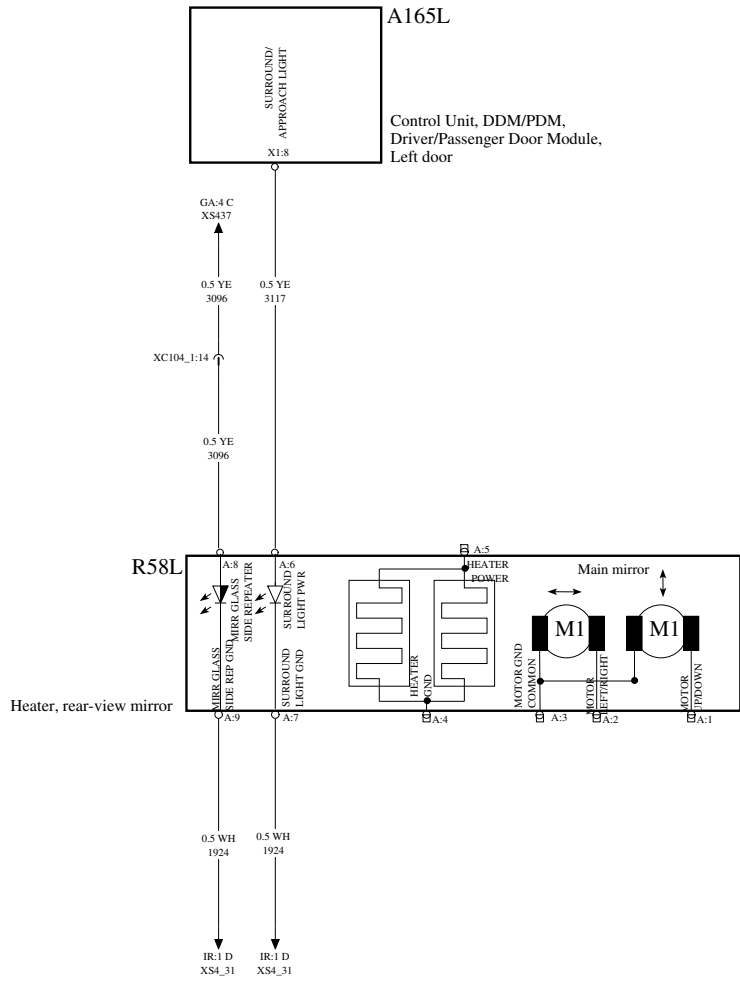

EXTERIOR LIGHTS, ROOF

IDENTIFICATION LIGHTS

WIRING DIAGRAM GF

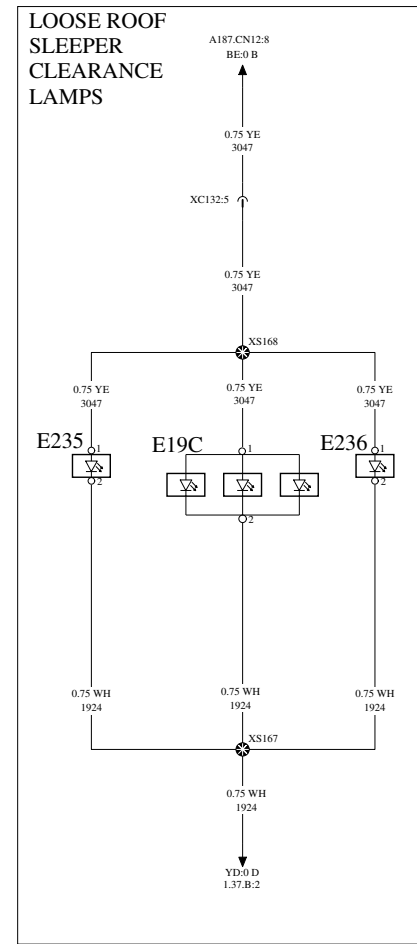
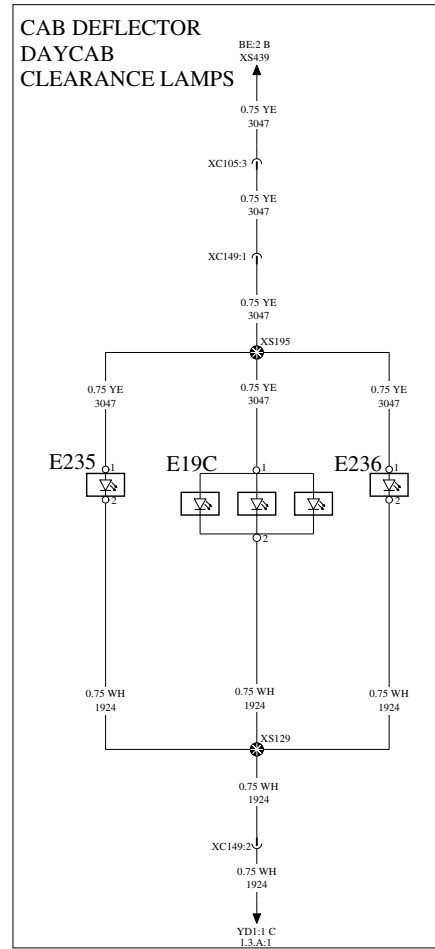
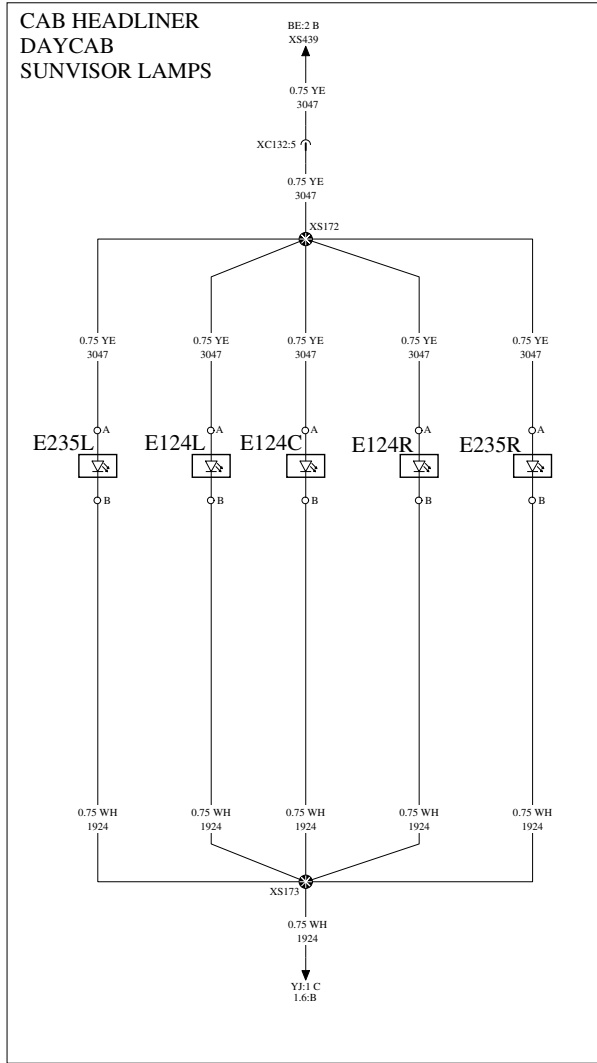

Document title
WIRING DIAGRAM, TEA2+ DIESEL

Legal Owner
Volvo Truck Corporation

Document No

24798720

Issue

01

Volume

1(1)

Page

47 (125)

WIPER AND WASHER

WIRING DIAGRAM GP

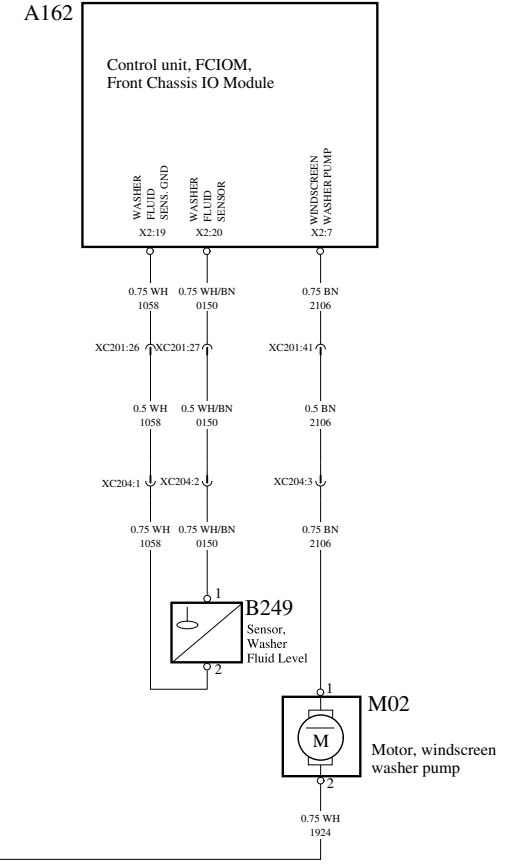
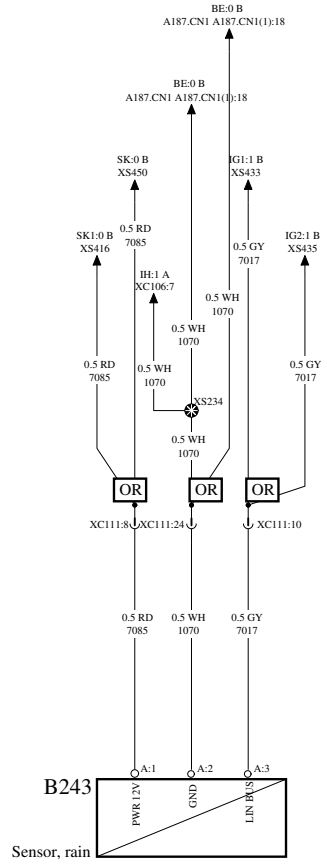
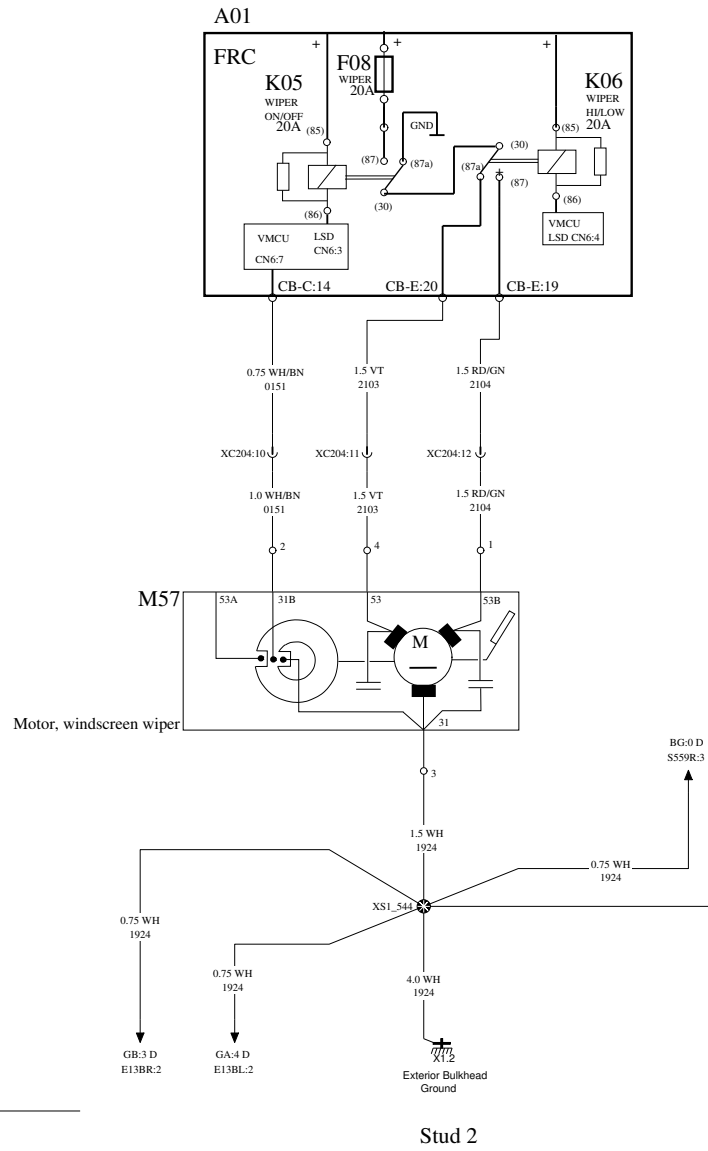

V O L V O

Document title WIRING DIAGRAM, TEA2+ DIESEL		Document No 24798720	Issue 01	Volume 1(1)	Page 48 (125)
Legal Owner Volvo Truck Corporation					

CLIMATE UNIT

WIRING DIAGRAM HA

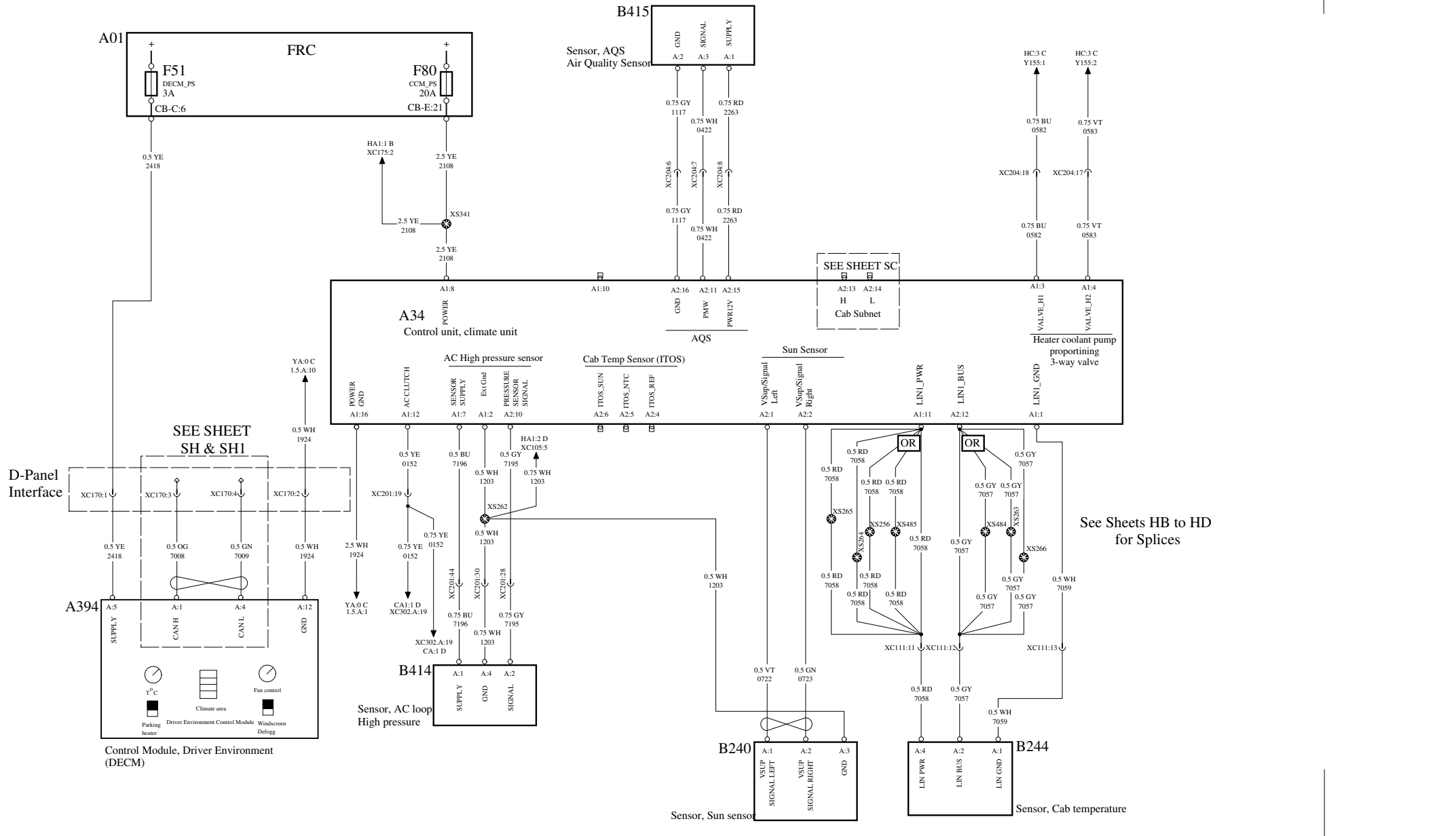

Document title
WIRING DIAGRAM, TEA2+ DIESEL

Legal Owner
Volvo Truck Corporation

Document No

24798720

Issue

01

Volume

1(1)

Page

49 (125)

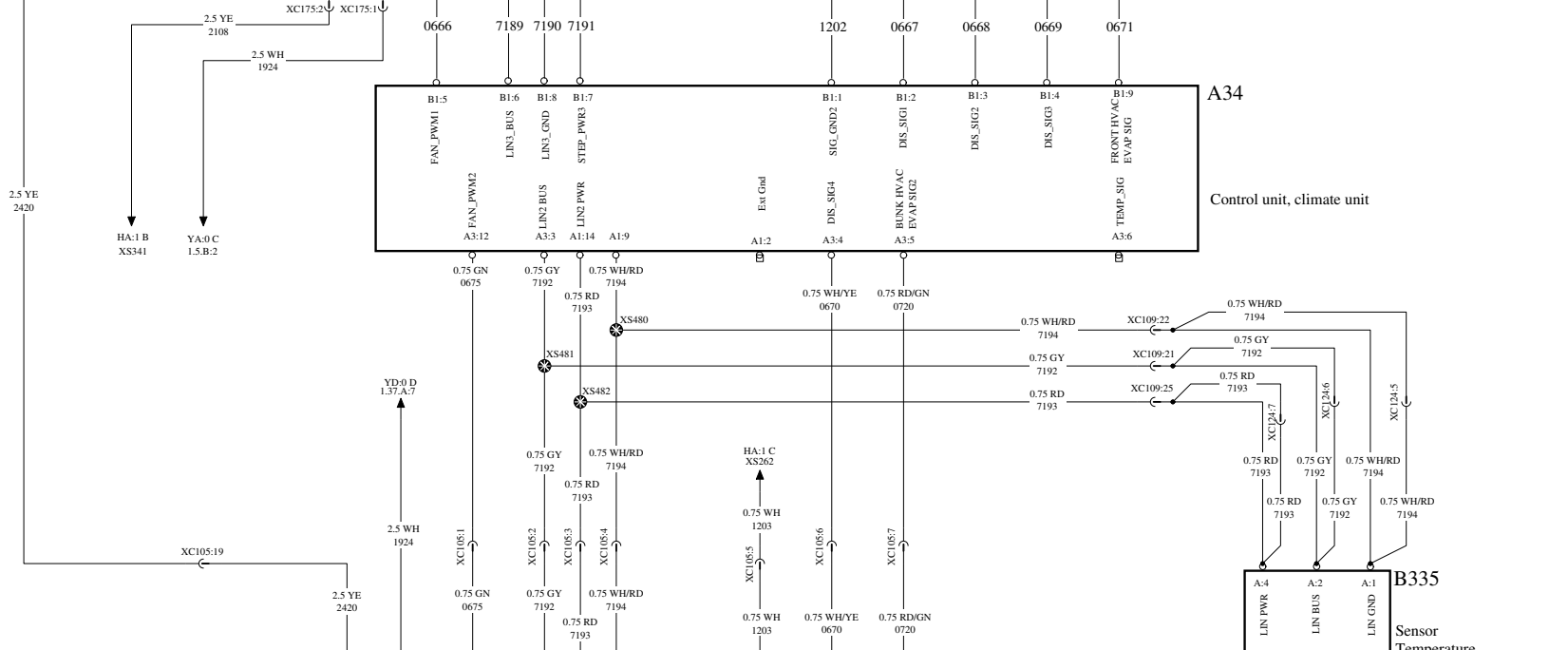
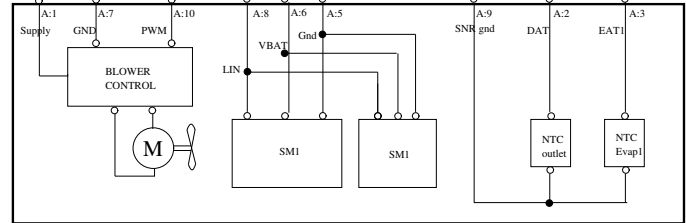
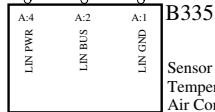
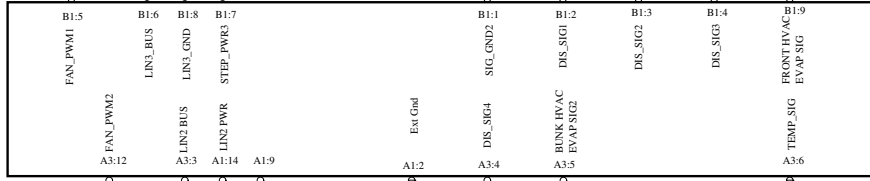
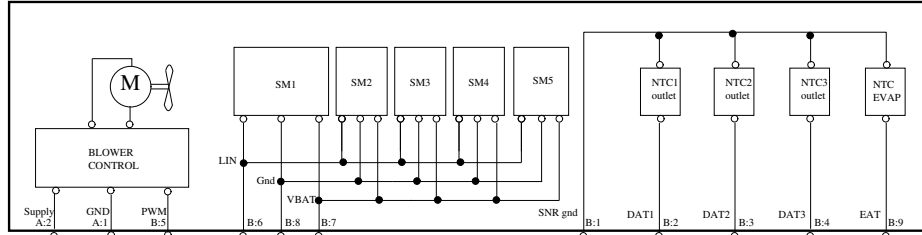
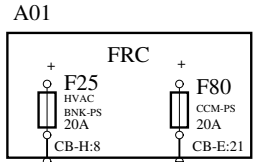

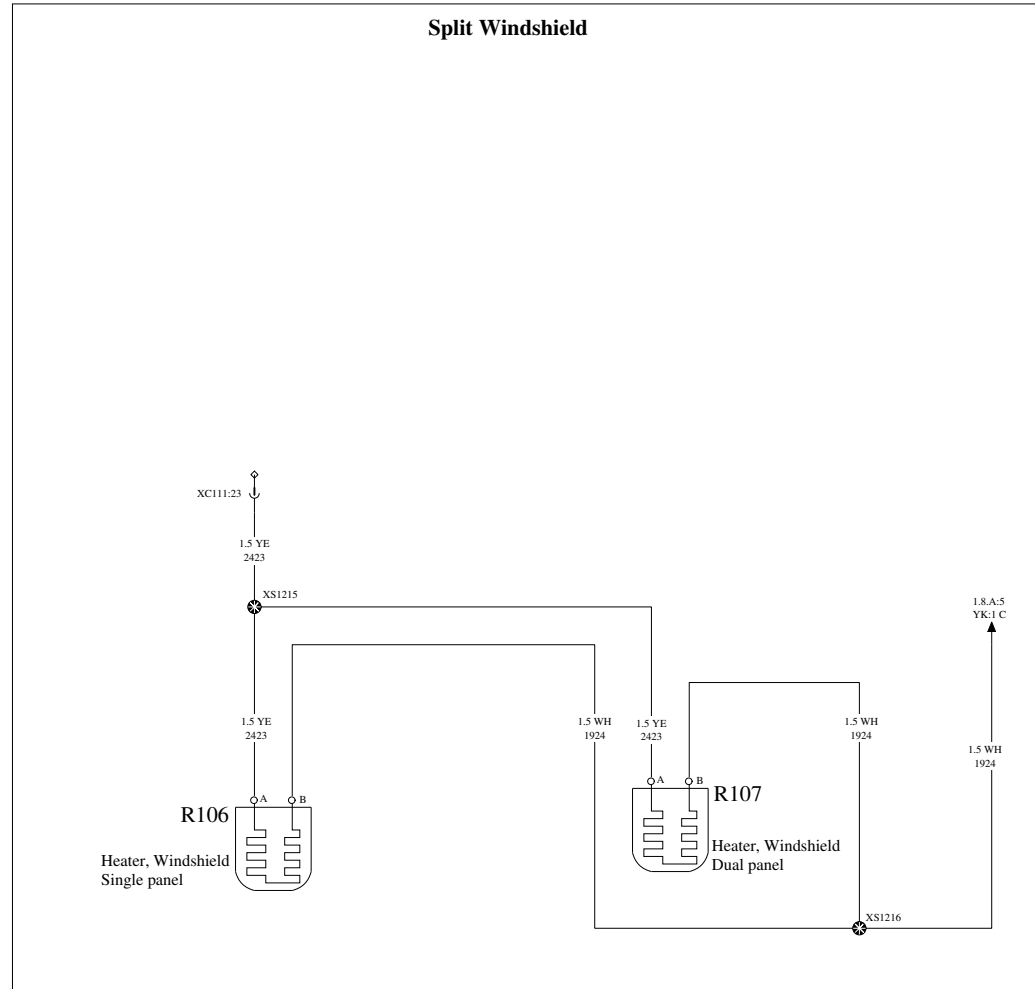
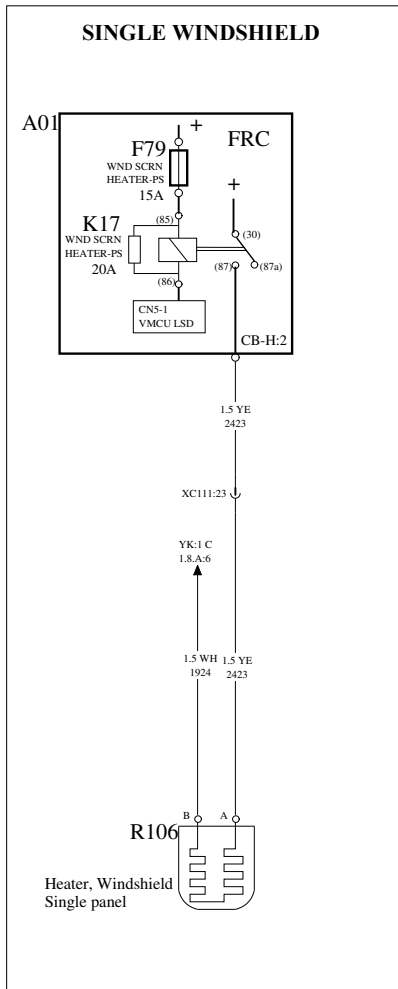

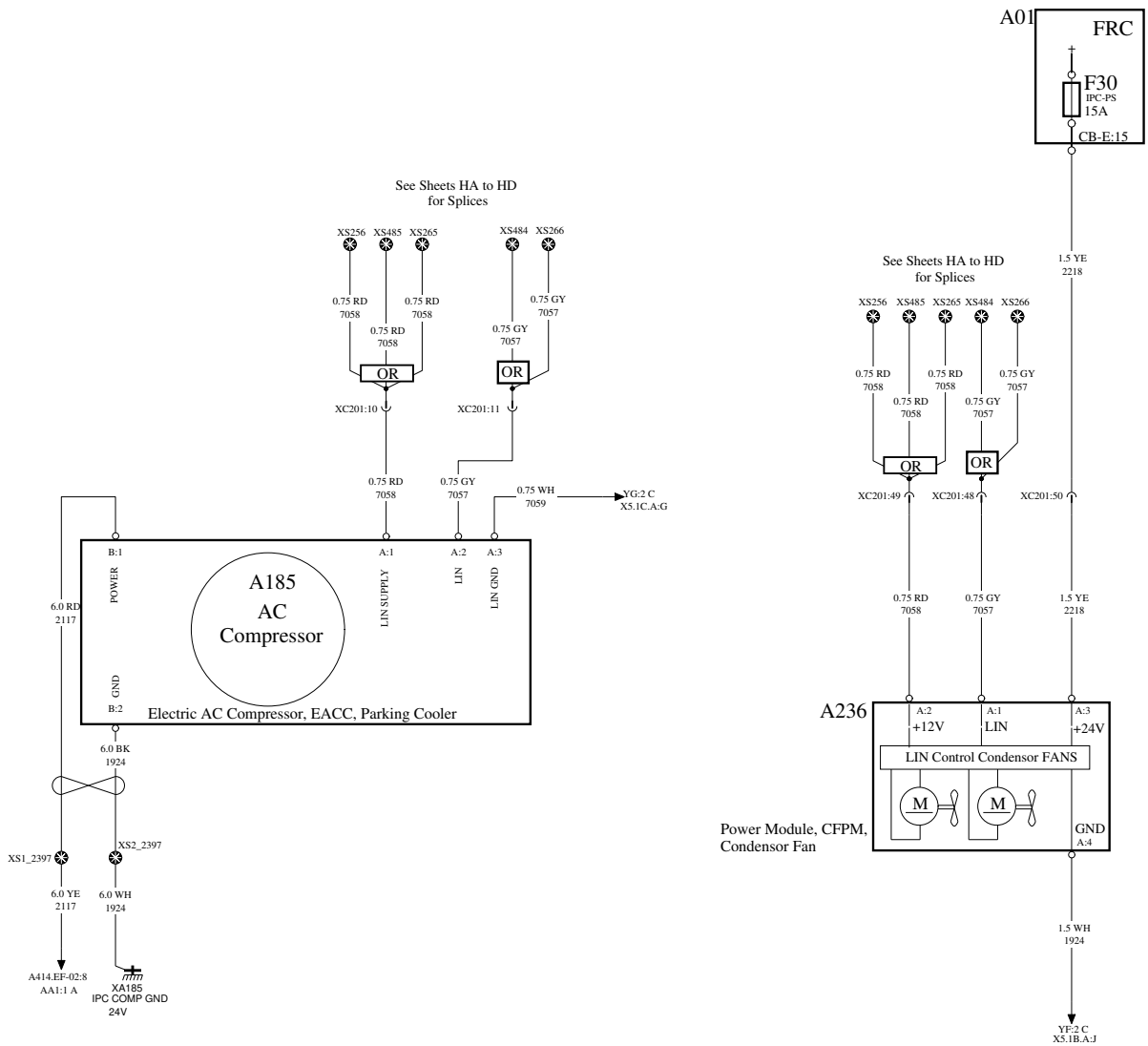

Document title WIRING DIAGRAM, TEA2+ DIESEL	Document No 24798720	Issue 01	Volume 1(1)	Page 52 (125)

PARKING HEATER - WATER

WIRING DIAGRAM HC

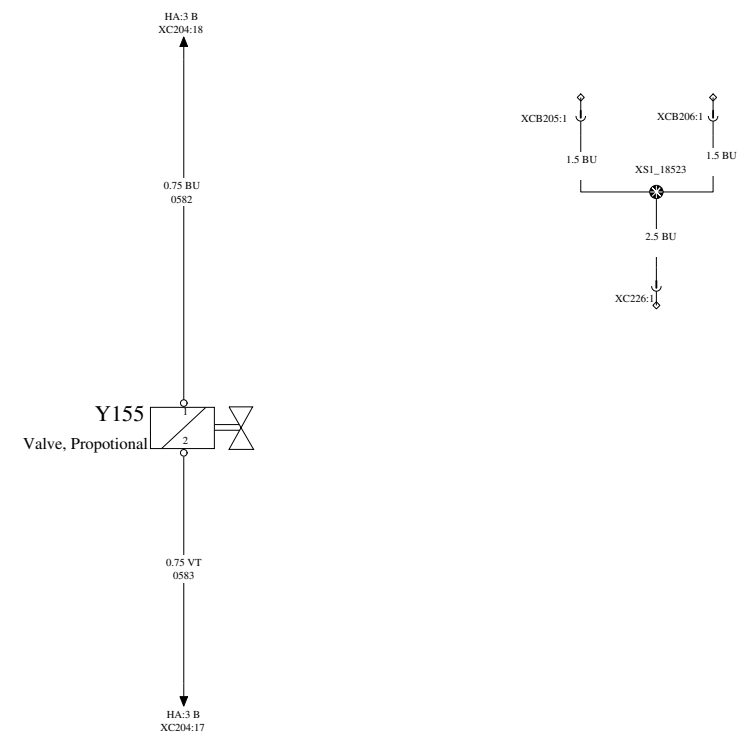
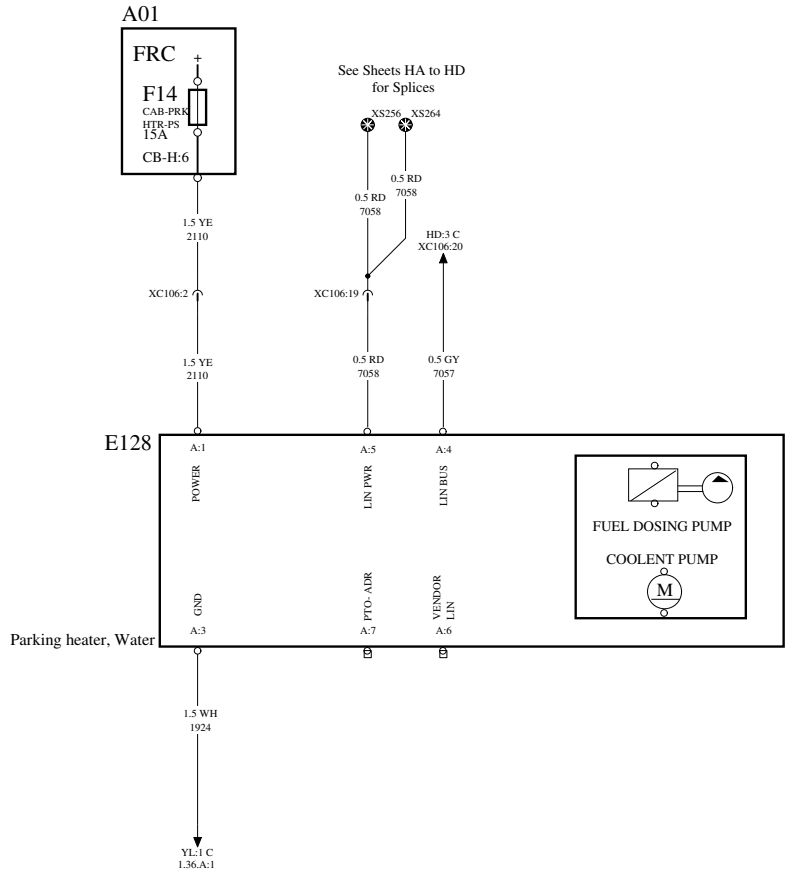

Document title WIRING DIAGRAM, TEA2+ DIESEL	Document No 24798720	Issue 01	Volume 1(1)	Page 53 (125)
Legal Owner Volvo Truck Corporation				

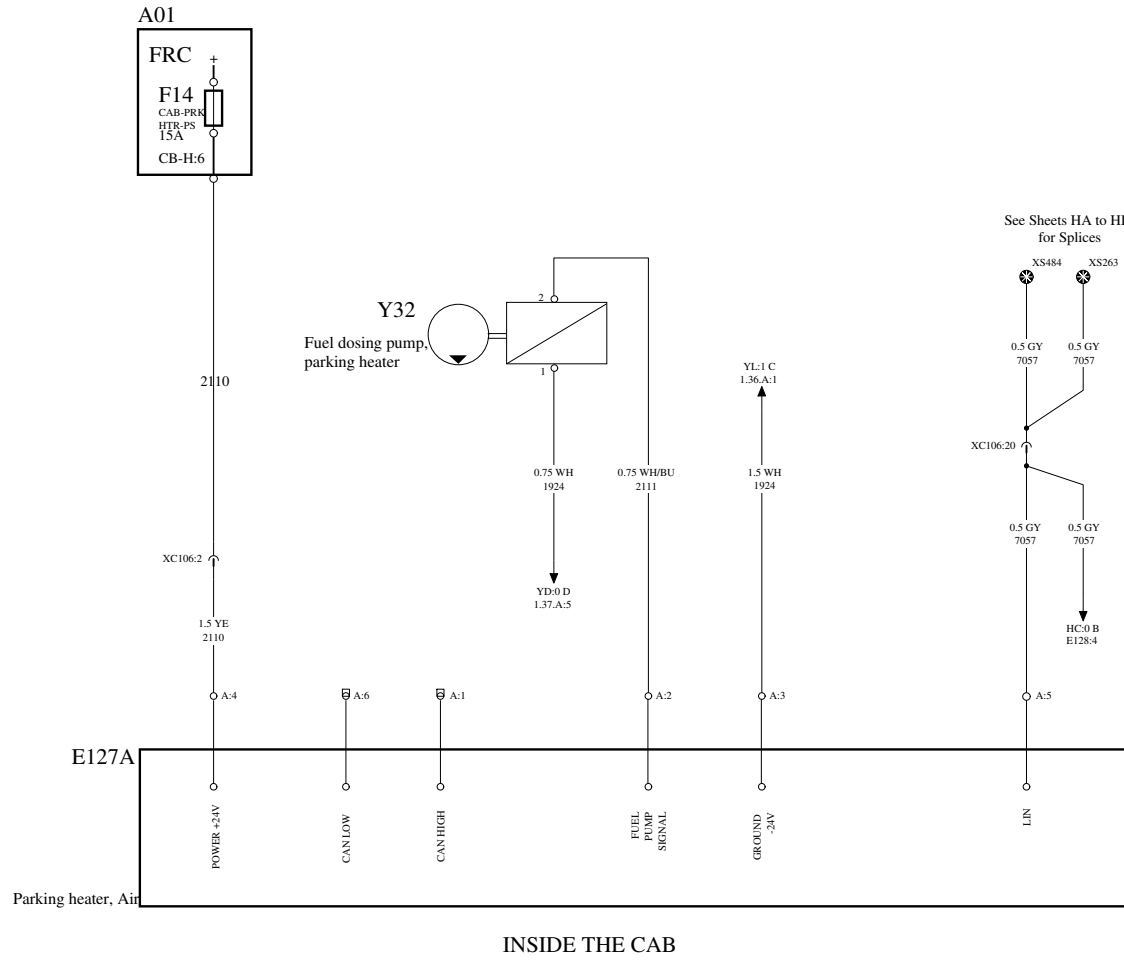

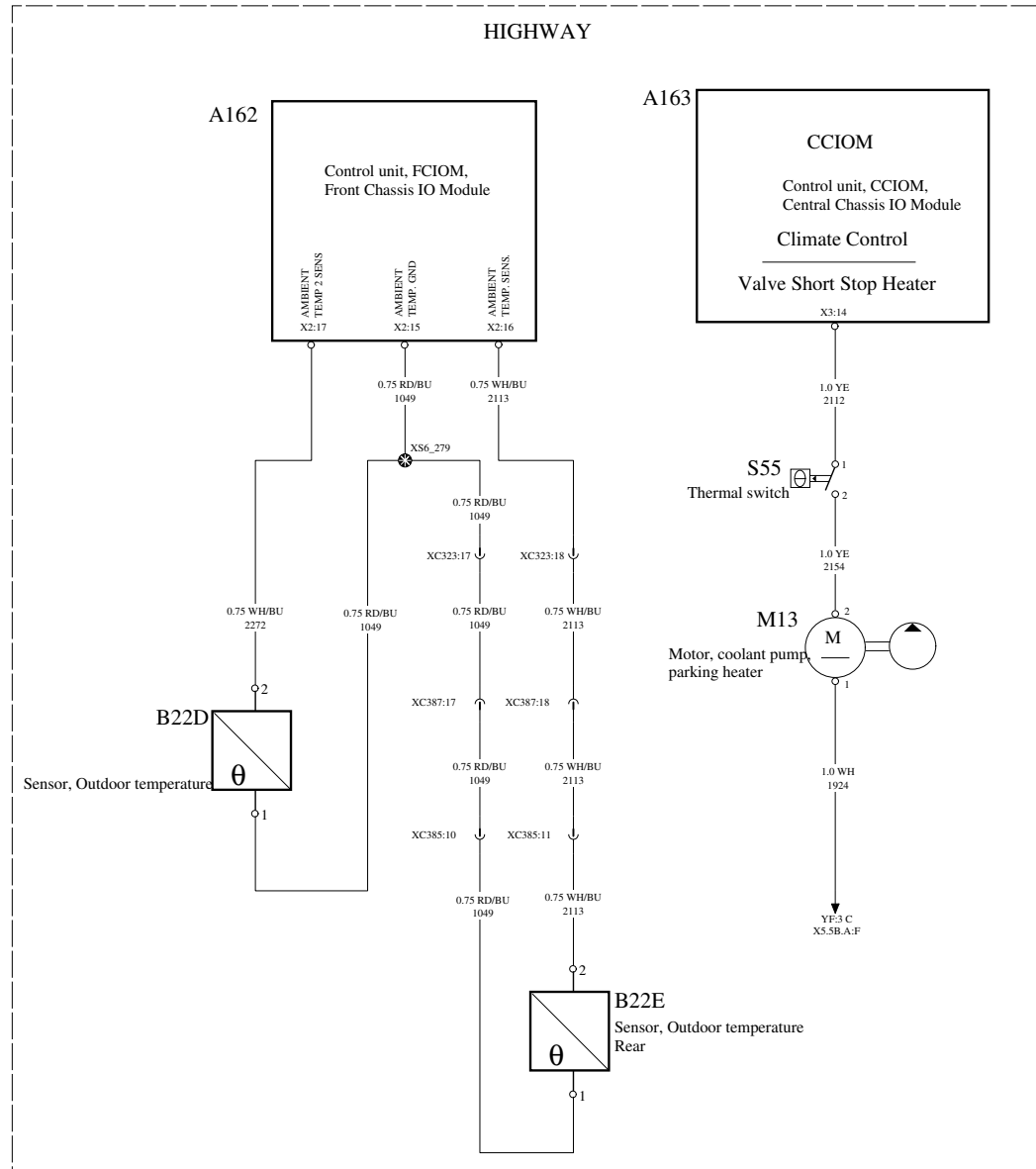

0

1

2

3

4

AIR FILTER MONITORING

AIR INTAKE SWITCHING

WIRING DIAGRAM HF

A

A

B

B

C

C

D

D

E

E

A163



Control unit, CCIOM,
Central Chassis IO Module

X3:21

0.75 BU
0712

DC:0 B
XC303.A:35

0.75 BU
0712

XC303.A.A:35
DE:0 B



Document title WIRING DIAGRAM, TEA2+ DIESEL
Legal Owner Volvo Truck Corporation

Document No 24798720

Issue 01

Volume 1(1)

Page 56 (125)

0

1

2

3

4

INTERIOR LIGHTS

BASE AND HIGH VARIANT

WIRING DIAGRAM IA1

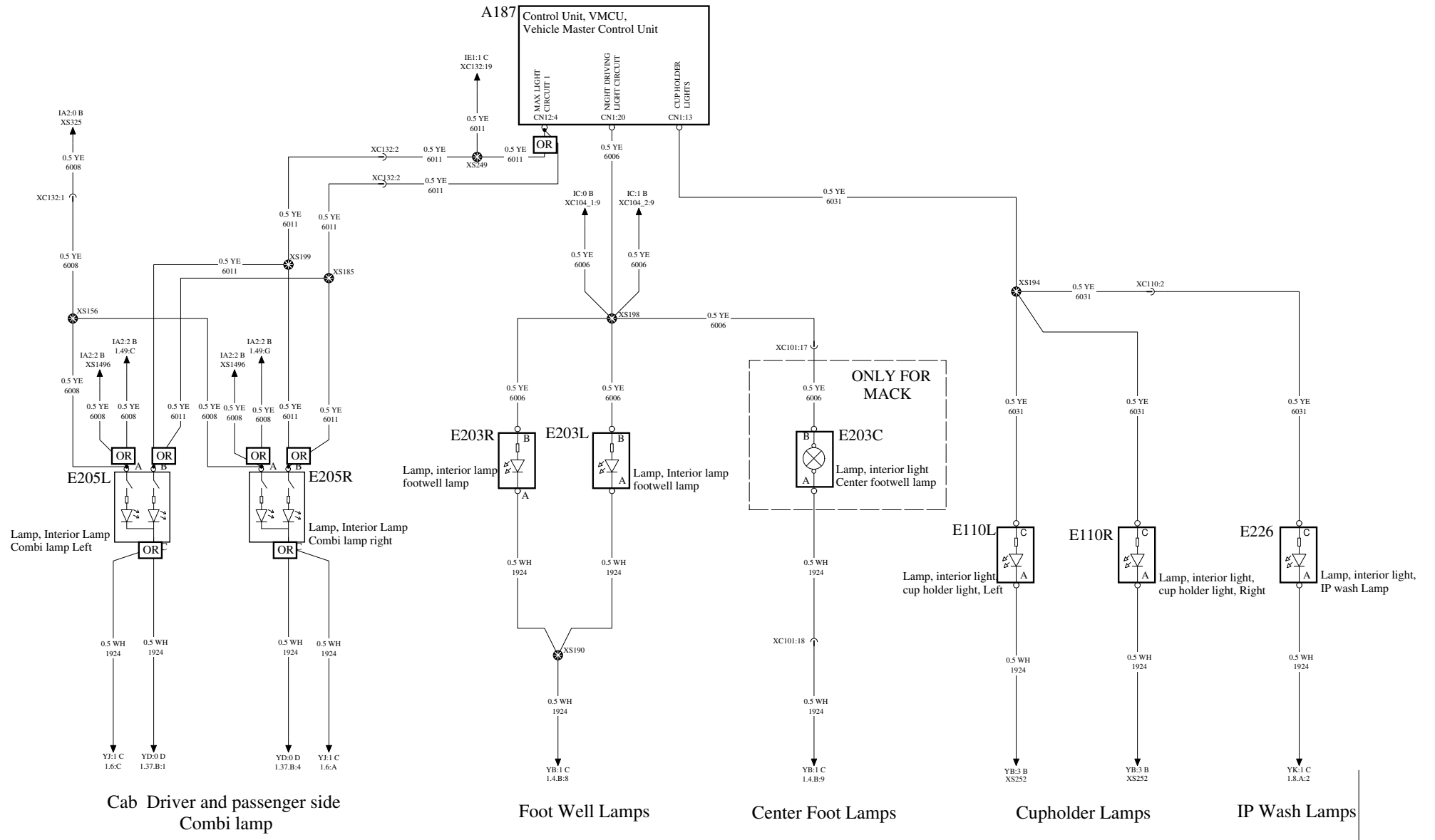

Document title
WIRING DIAGRAM, TEA2+ DIESEL

Legal Owner
Volvo Truck Corporation

Document No
24798720

Issue
01

Volume
1(1)

Page
57 (125)

INTERIOR LIGHTS

BASE AND HIGH VARIANT

WIRING DIAGRAM IA2

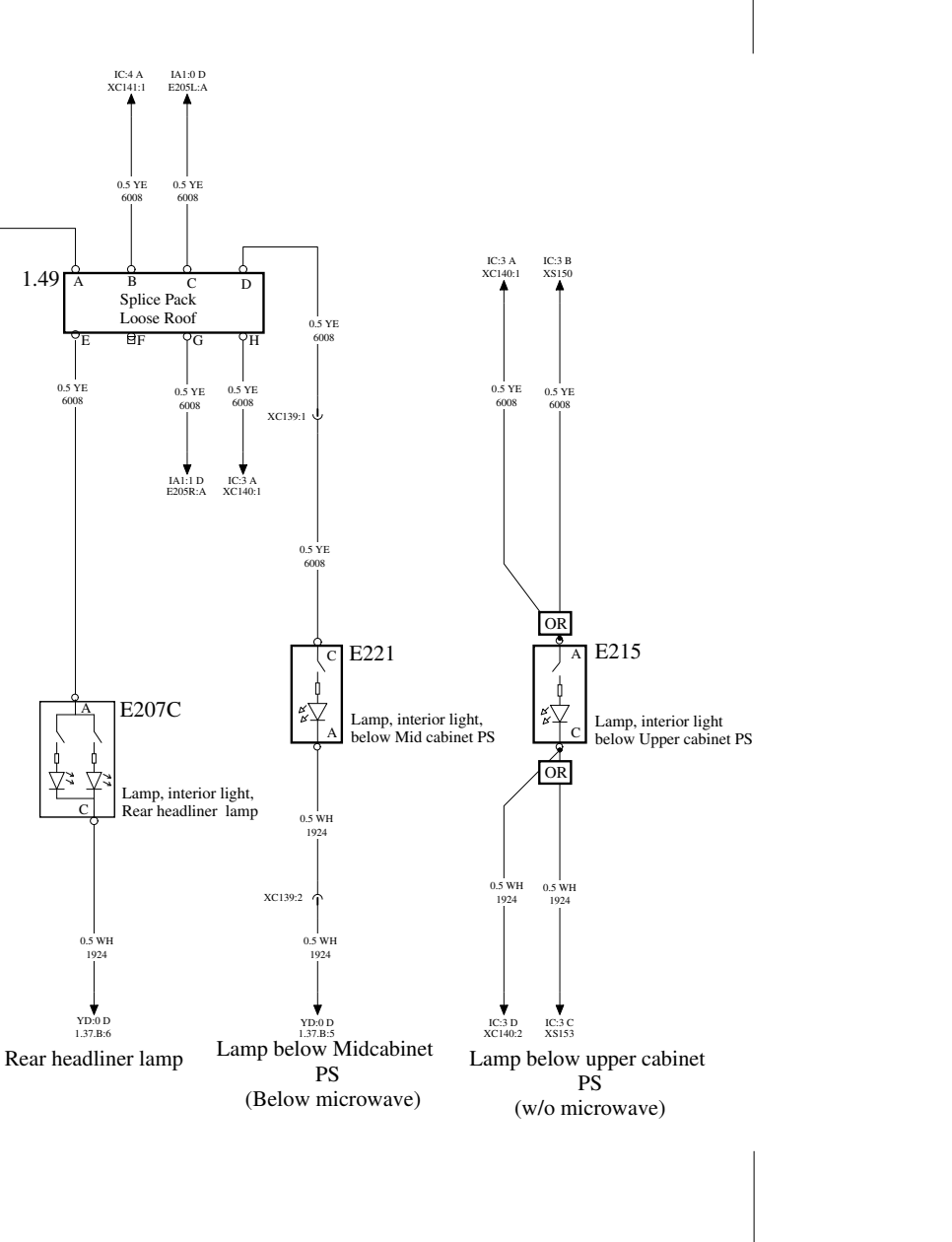
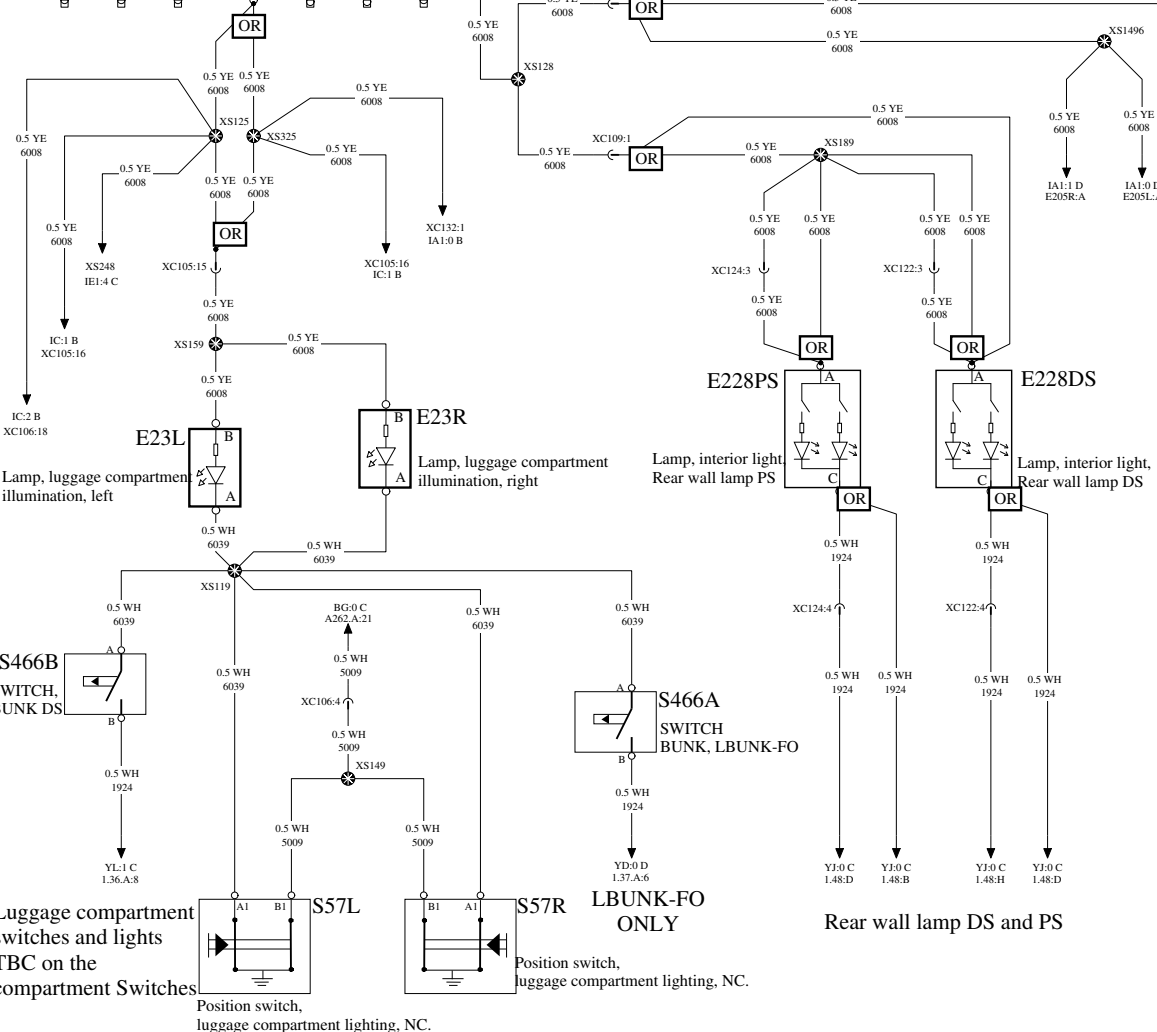
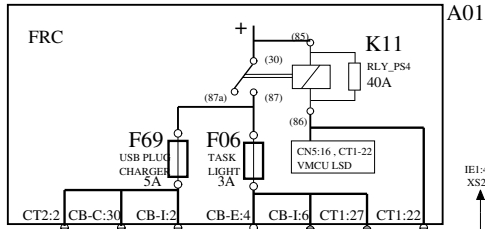

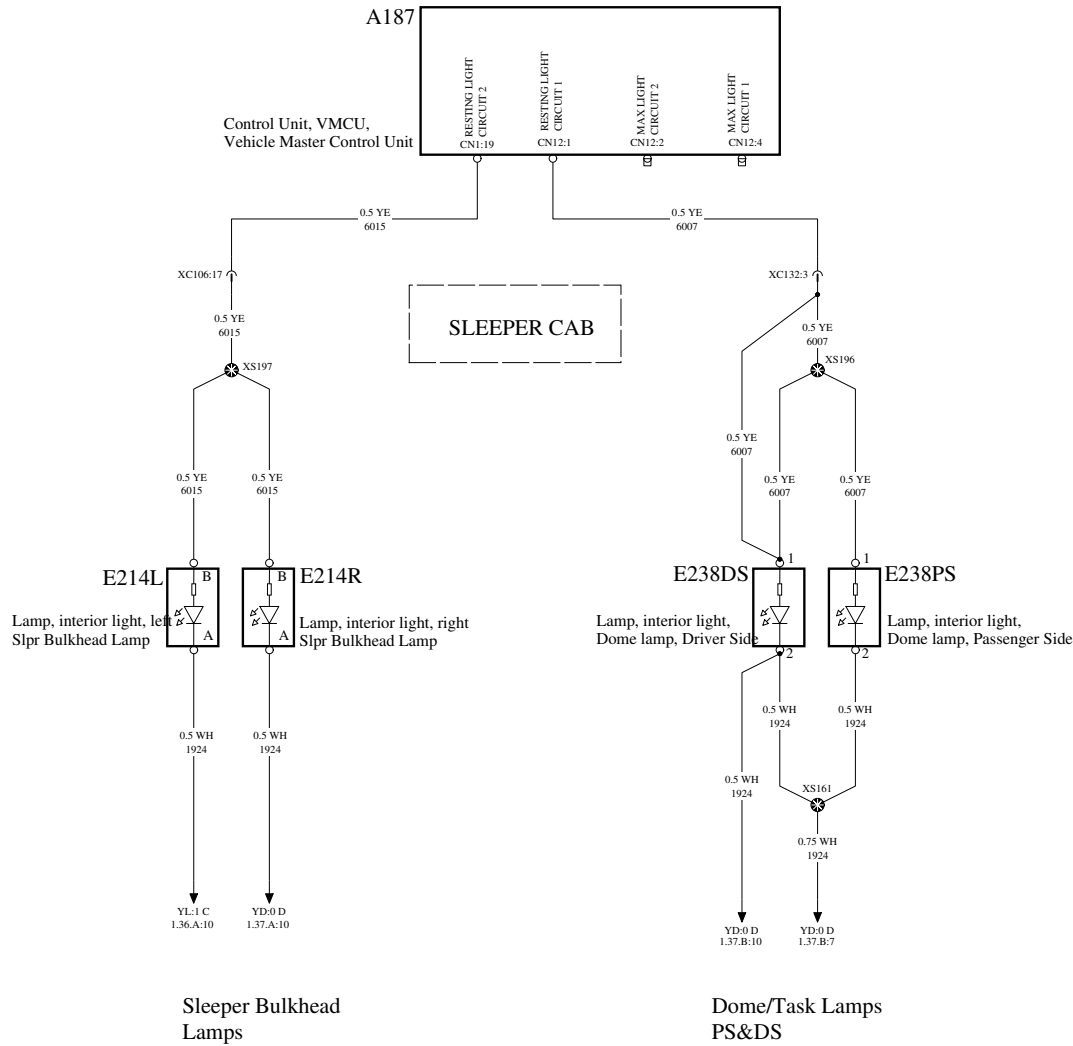

INTERIOR LIGHTS

BASE, MID AND HIGH VARIANT

WIRING DIAGRAM IC

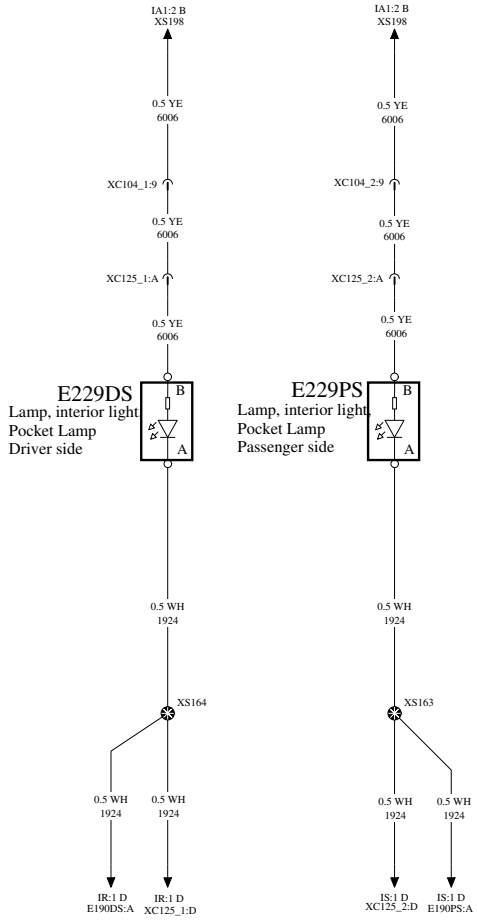

Map Pocket Lamps

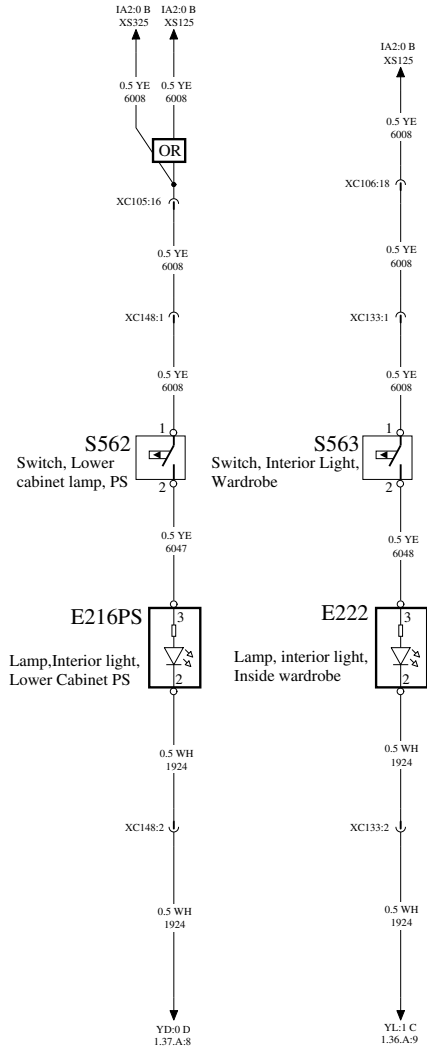

Lower Cabinet PS lamp

Lower inside wardrobe DS

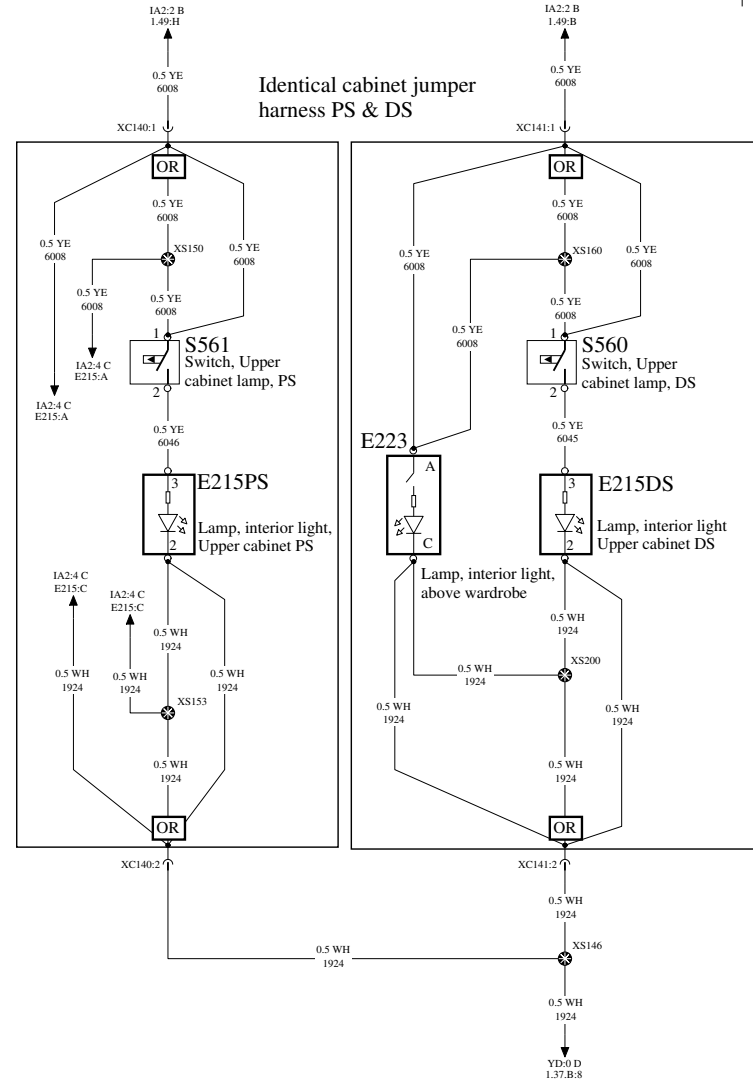

Upper cabinet lamp PS

Lamp below upper cabinet PS

Upper cabinet lamp DS



Document title
WIRING DIAGRAM, TEA2+ DIESEL

Legal Owner
Volvo Truck Corporation

Document No

24798720

Issue

01

Volume

1(1)

Page

60 (125)

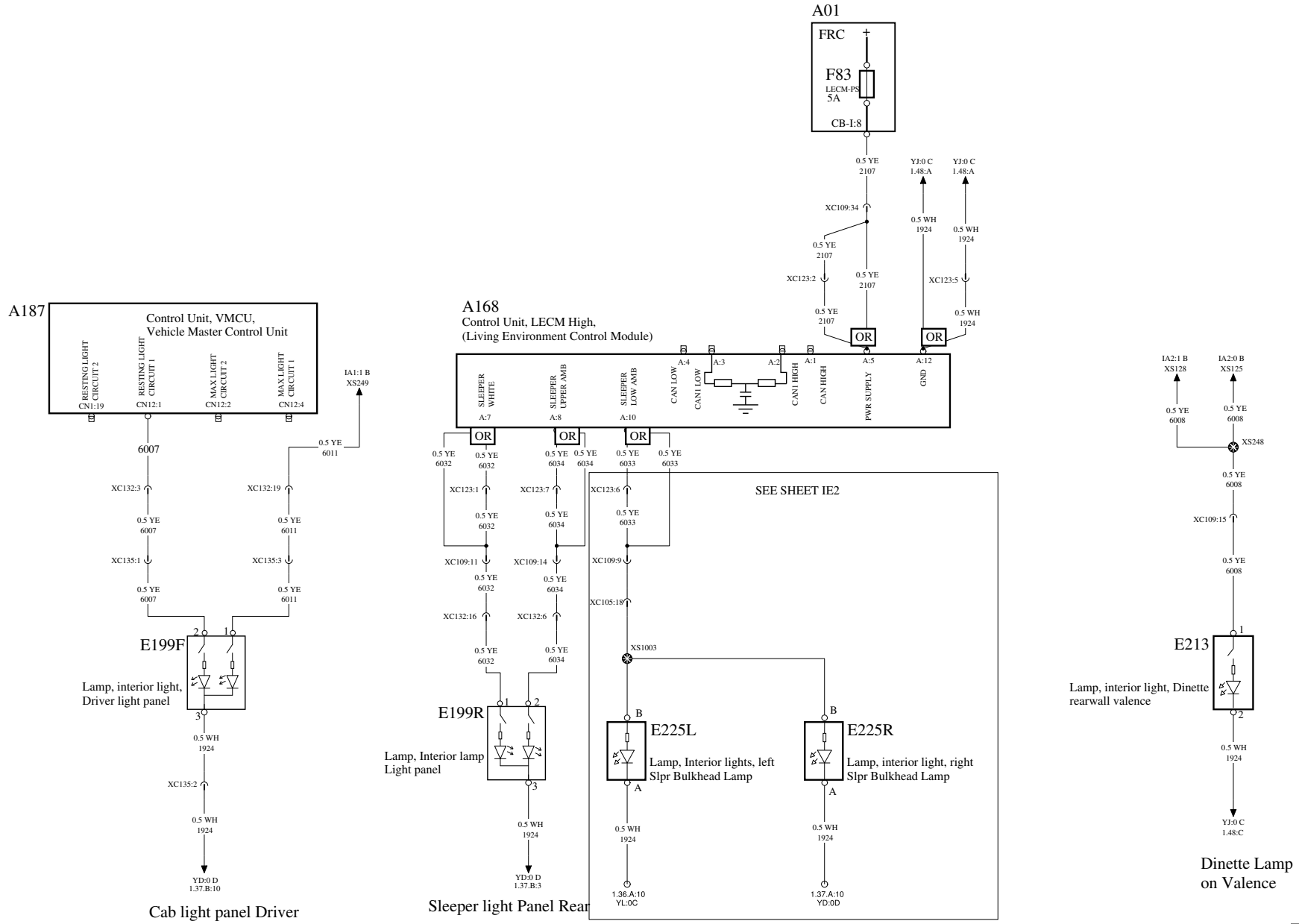

INTERIOR LIGHTS MID

MID VARIANT

WIRING DIAGRAM IE2

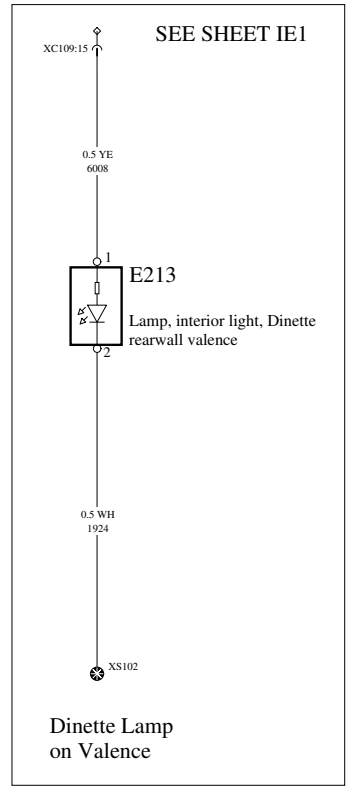
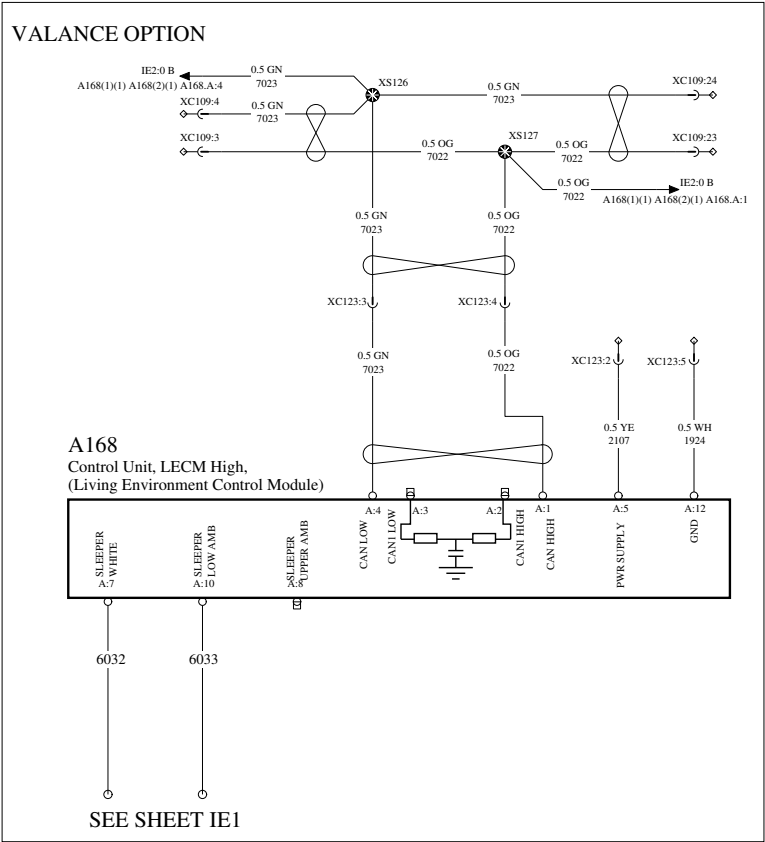
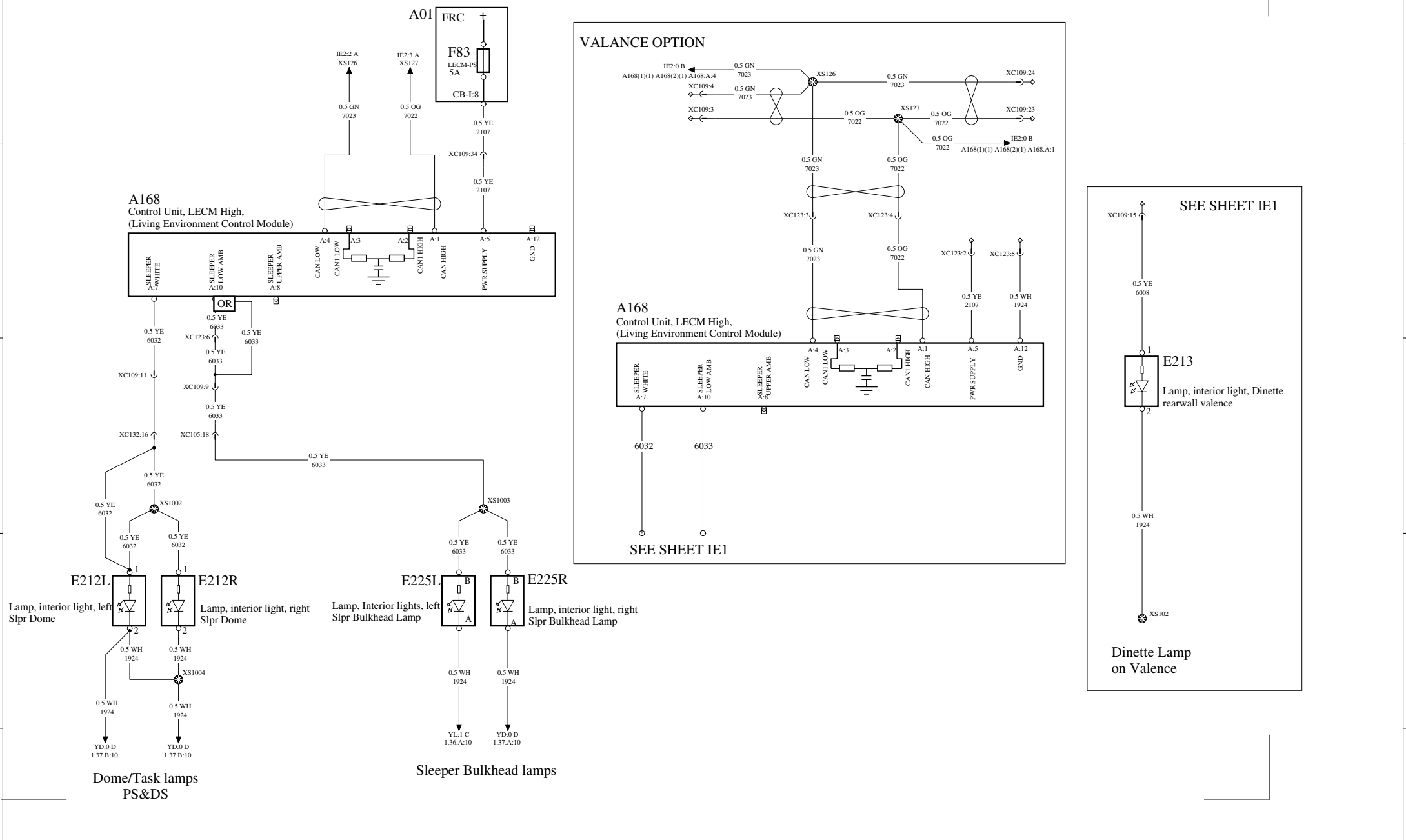

Document title WIRING DIAGRAM, TEA2+ DIESEL		Document No	Issue	Volume	Page
Legal Owner Volvo Truck Corporation		24798720	01	1(1)	62 (125)

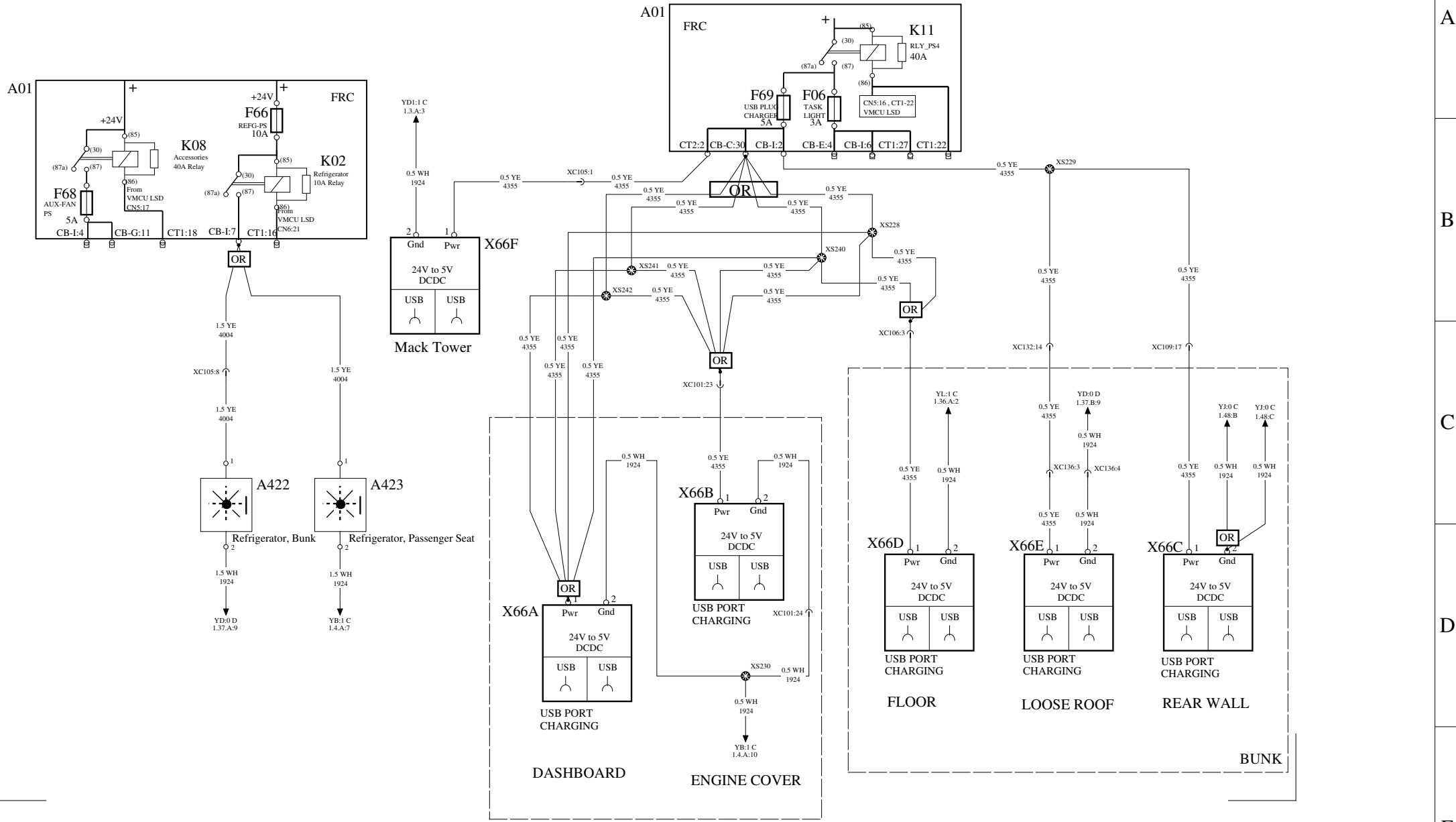

COMFORT ACCESSORIES PDC

12V PDC - IP

WIRING DIAGRAM IG

12V PDC - IP

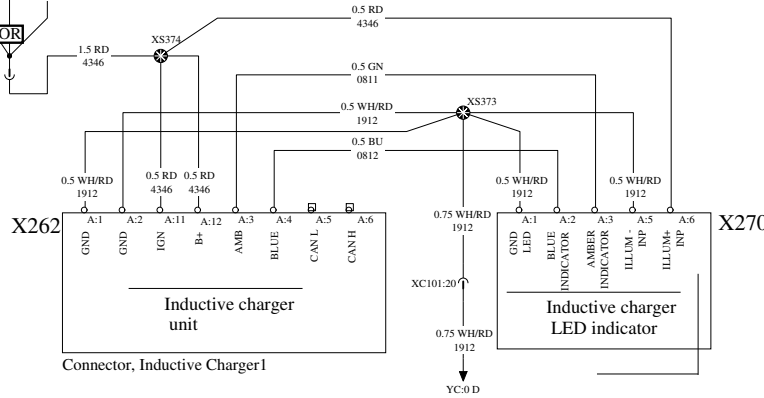
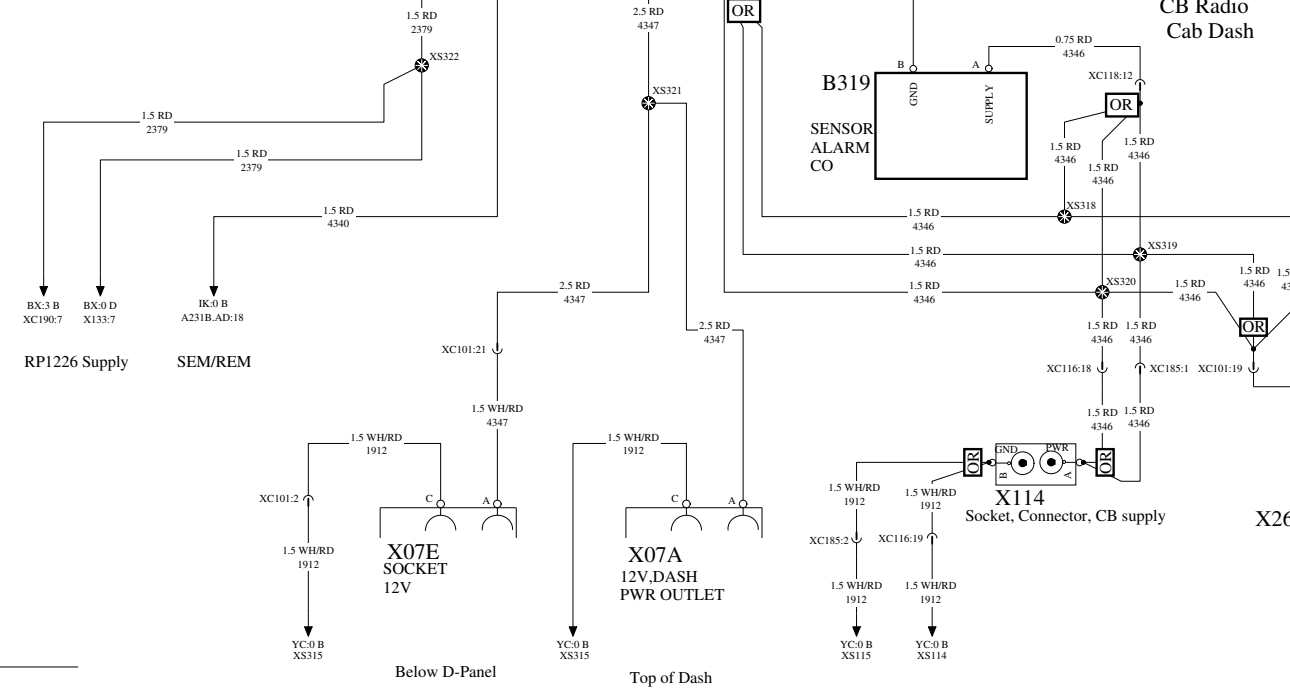
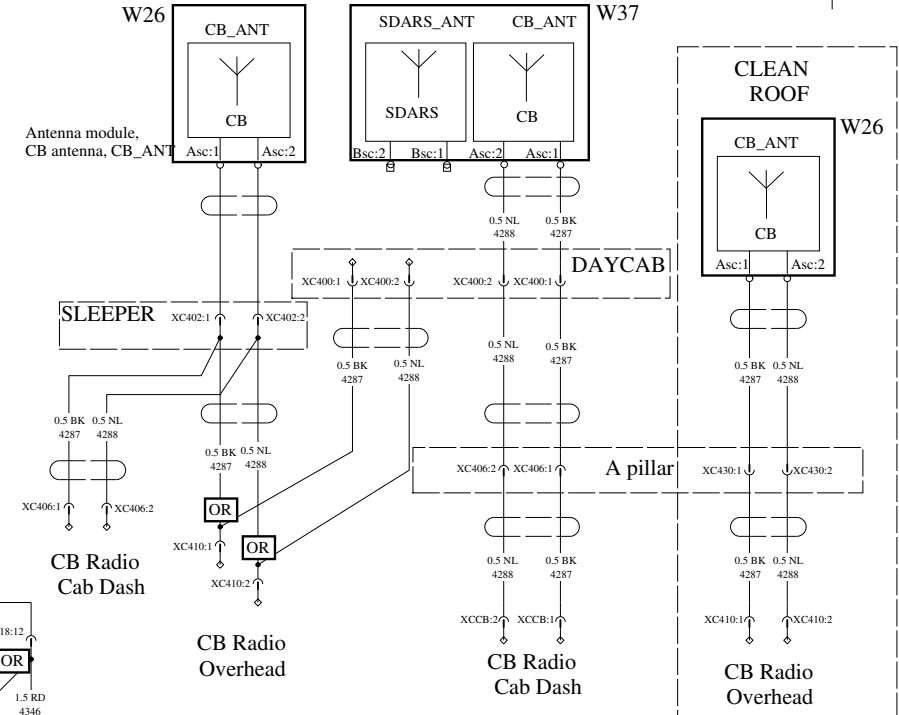
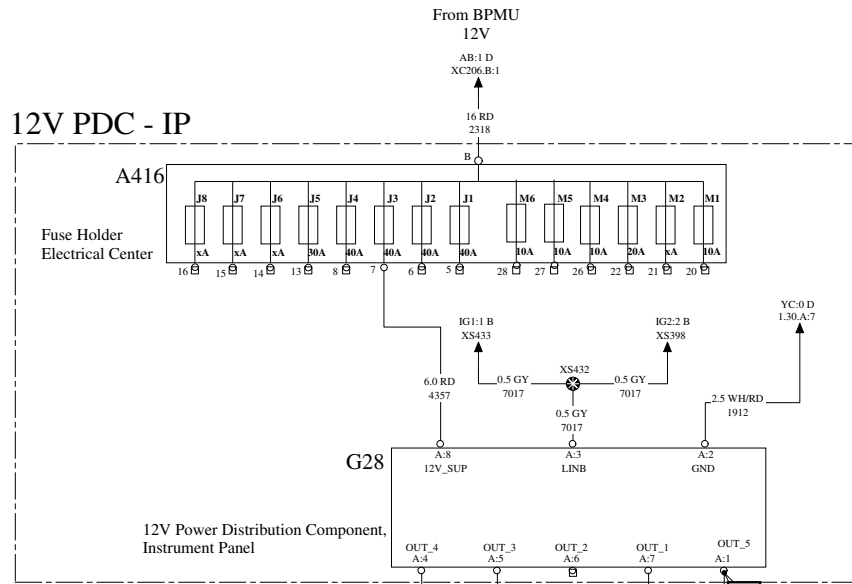

Document title WIRING DIAGRAM, TEA2+ DIESEL		Document No	Issue	Volume	Page
Legal Owner Volvo Truck Corporation		24798720	01	1(1)	64 (125)

COMFORT ACCESSORIES PDC

12V PDC, BUNK

WIRING DIAGRAM IG1

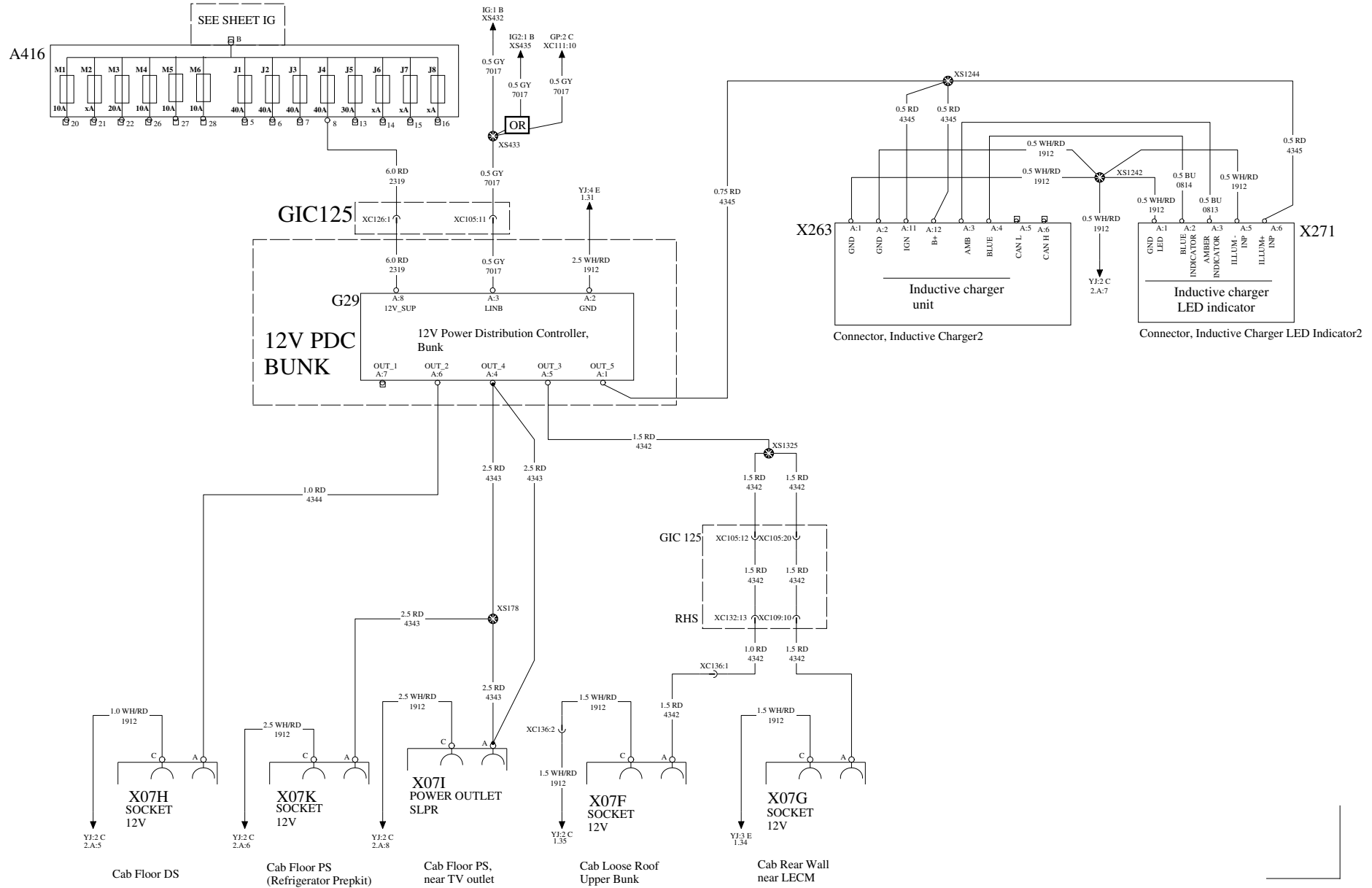

Document title
WIRING DIAGRAM, TEA2+ DIESEL

Legal Owner
Volvo Truck Corporation

Document No
24798720

Issue
01

Volume
1(1)

Page
65 (125)

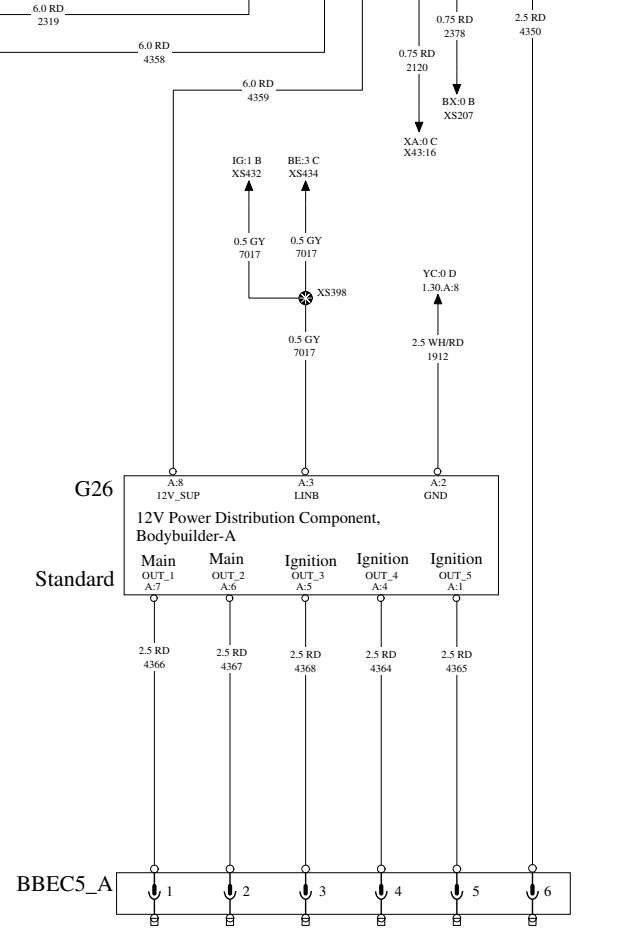
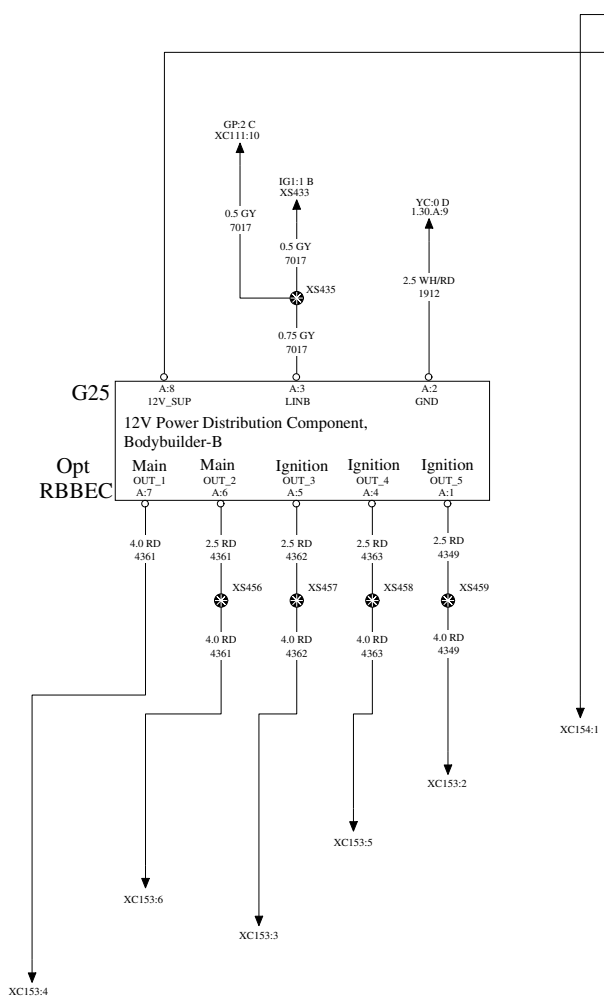
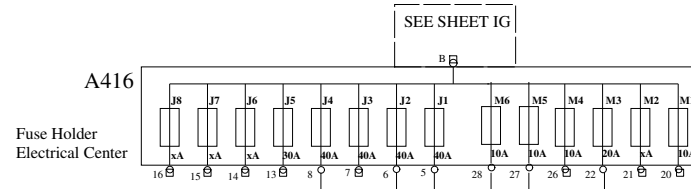

COMFORT ACCESSORIES 120VAC

SHORE POWER & INVERTER

WIRING DIAGRAM IH

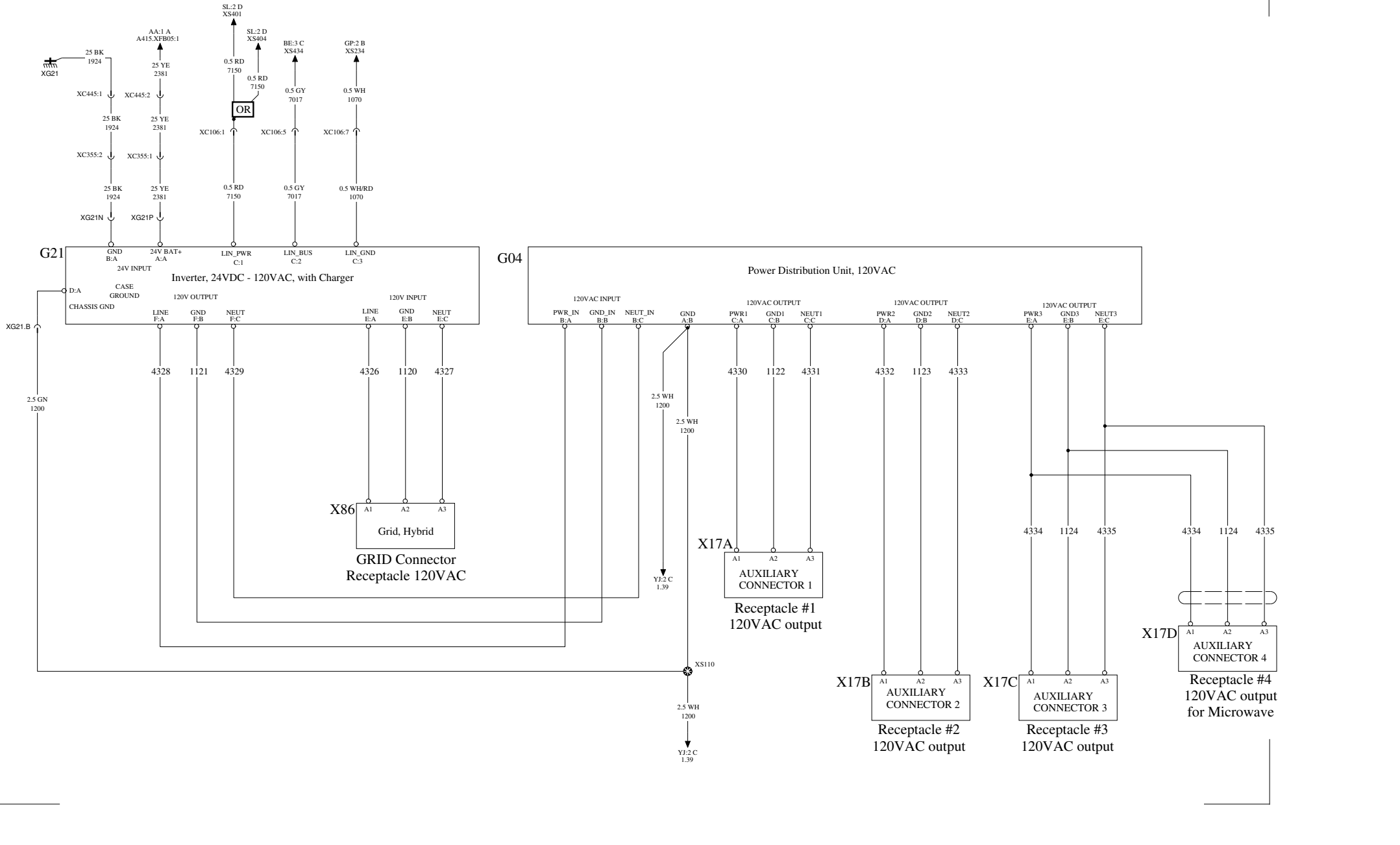

A

B

C

D

E

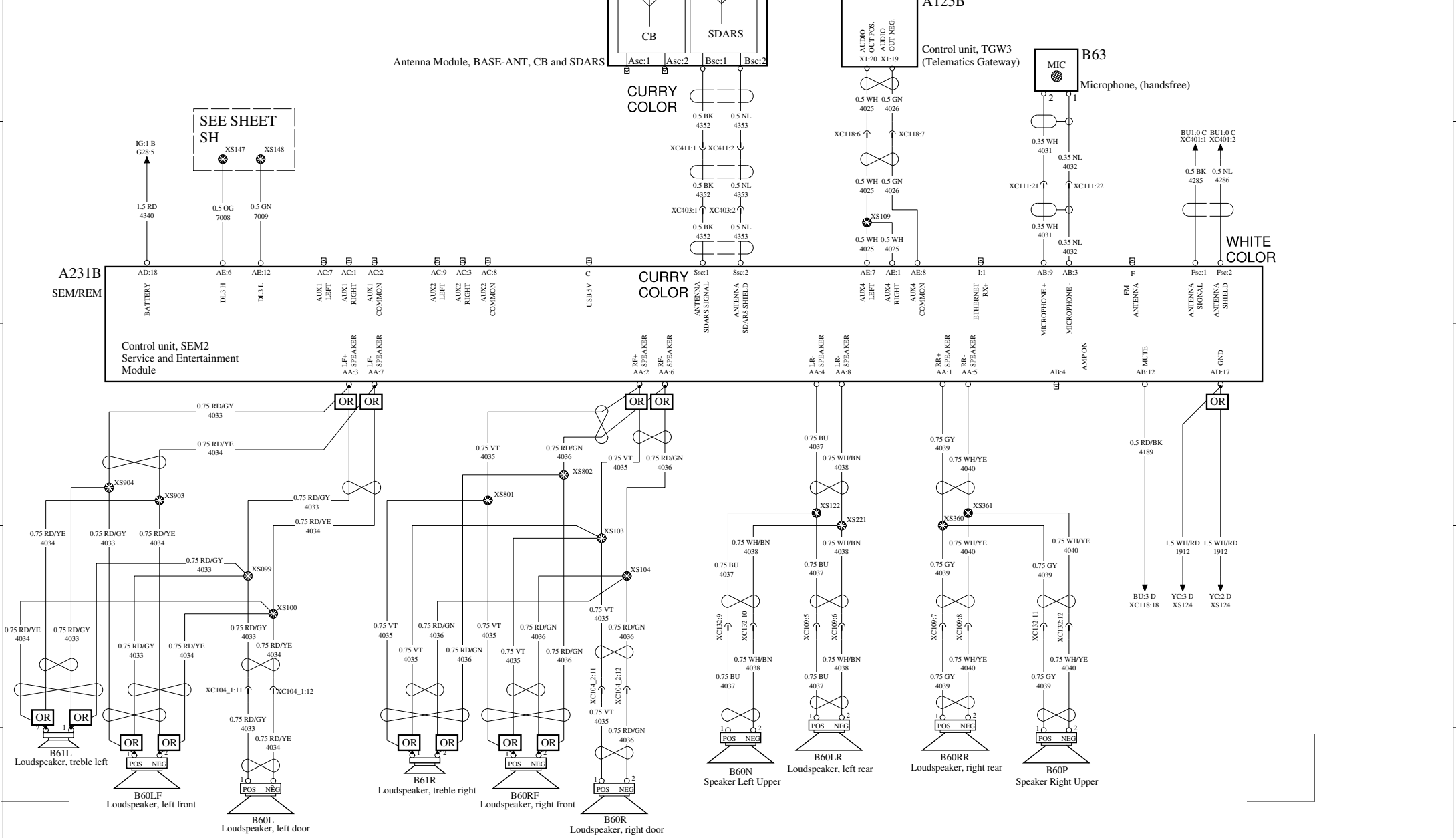

VOLVO	Document title WIRING DIAGRAM, TEA2+ DIESEL	Document No 24798720	Issue 01	Volume 1(1)	Page 68 (125)
	Legal Owner Volvo Truck Corporation				

INFOTAINMENT 24V AMPLIFIER

WIRING DIAGRAM IL

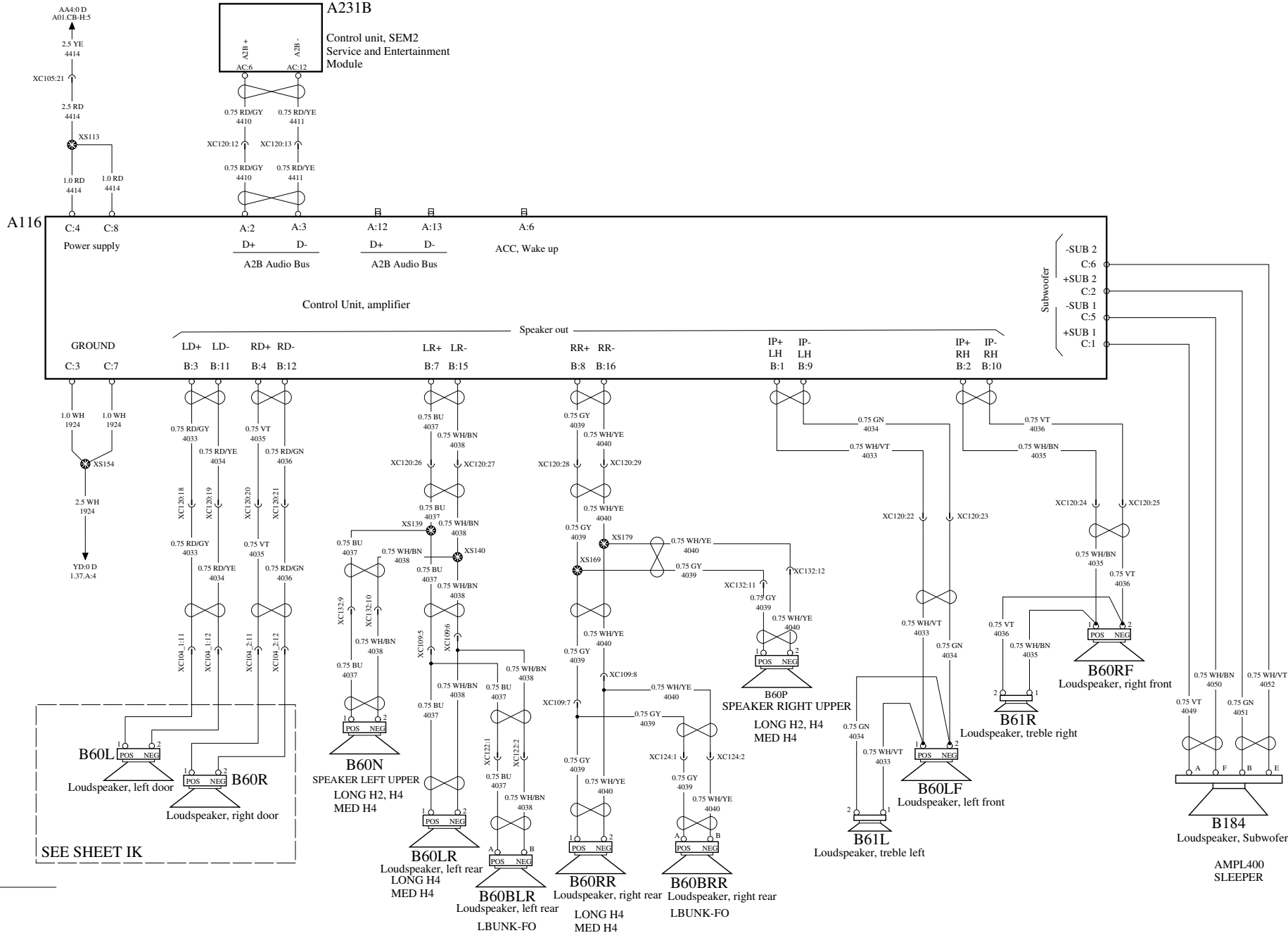

VOLVO

Document title
WIRING DIAGRAM, TEA2+ DIESEL

Legal Owner
Volvo Truck Corporation

Document No

24798720

Issue

01

Volume

1(1)

Page

69 (125)

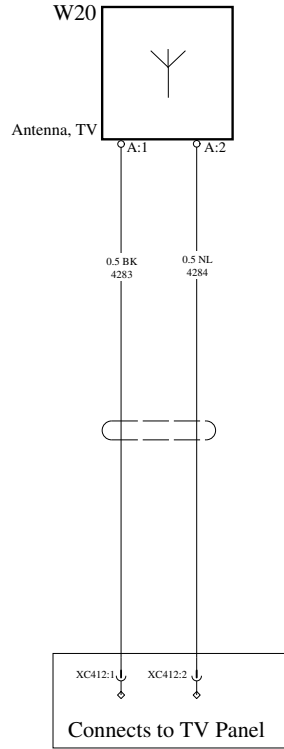

V O L V O

Document title
WIRING DIAGRAM, TEA2+ DIESEL

Document No

Issue

Volume

Page

Legal Owner
Volvo Truck Corporation

24798720

01

1(1)

70 (125)

A

B

C

D

E

A

B

C

D

E

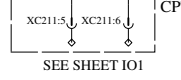
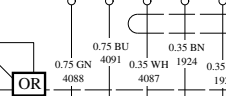
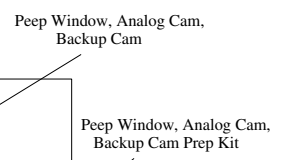
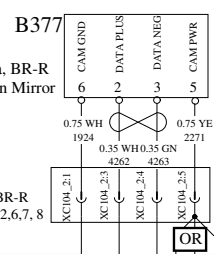
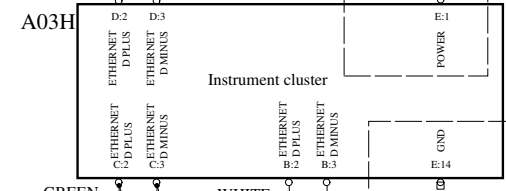
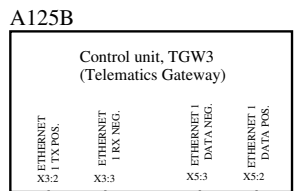
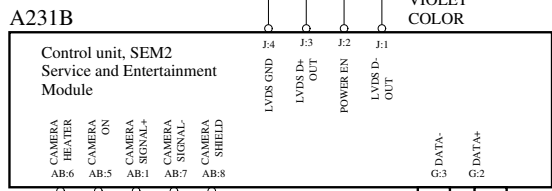
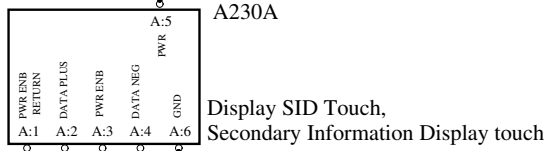

SUPPLIER PARTS INTERFACE

Trailer Camera connector

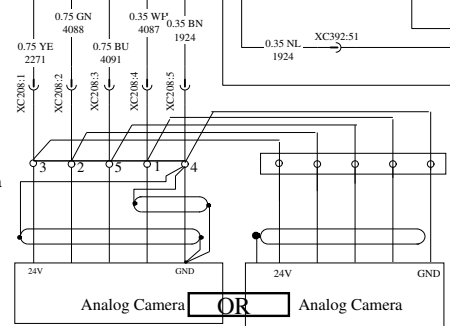

signal:4265
Ecopl:4265

0 INFOTAINMENT CAMERAS

1 VISION CAMERA ETHERNET SWITCH

3 WIRING DIAGRAM IO1

A

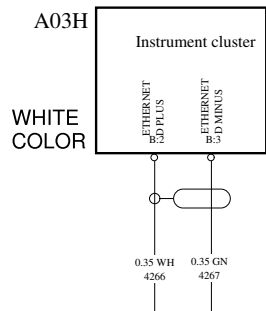

B BACKUP CAMERA W/O ETHERNET SWITCH

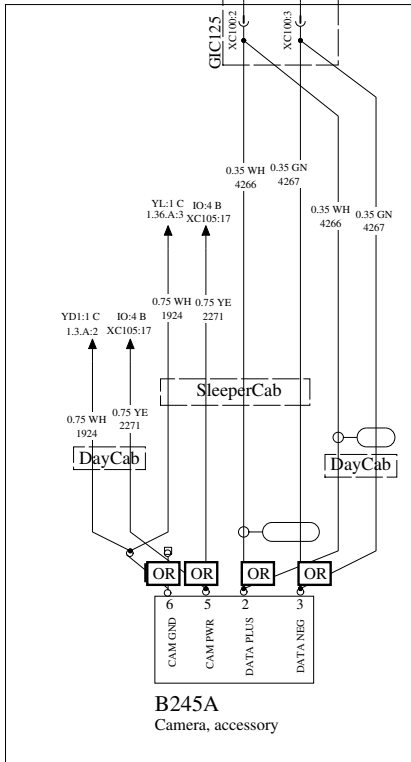

C

D

E

2 BACKUP CAMERA W/ ETHERNET SWITCH

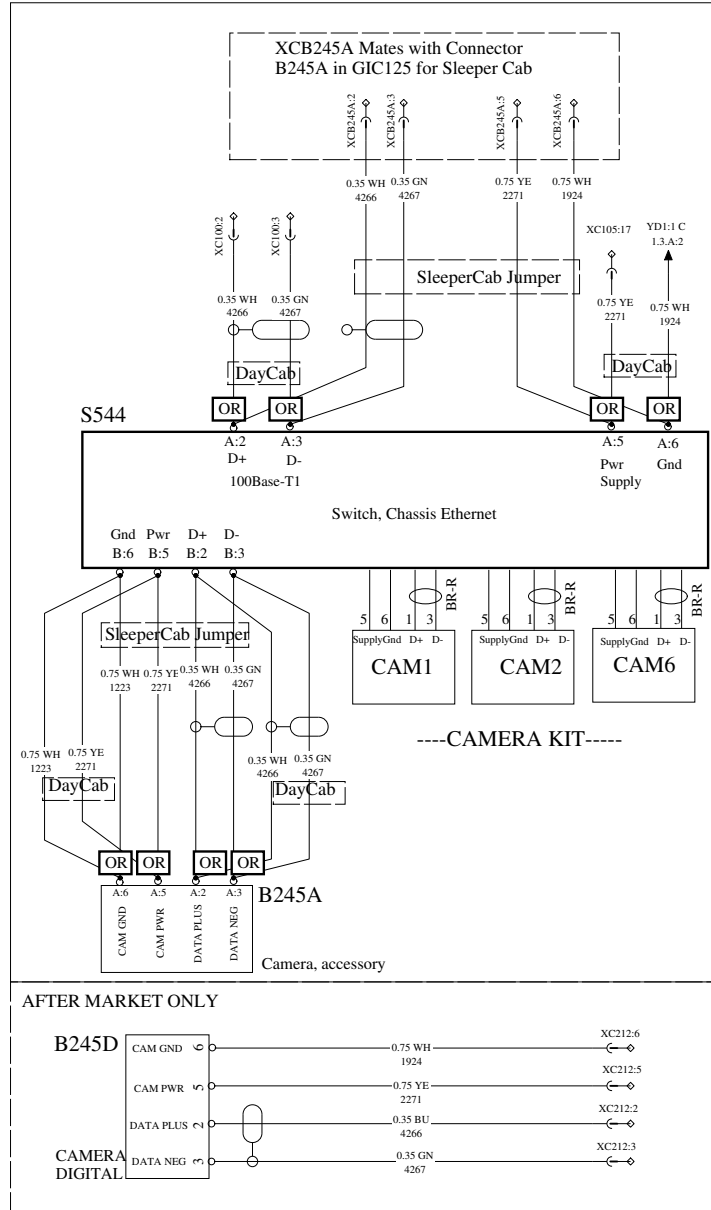

4 SINGLE AUX CAMERA

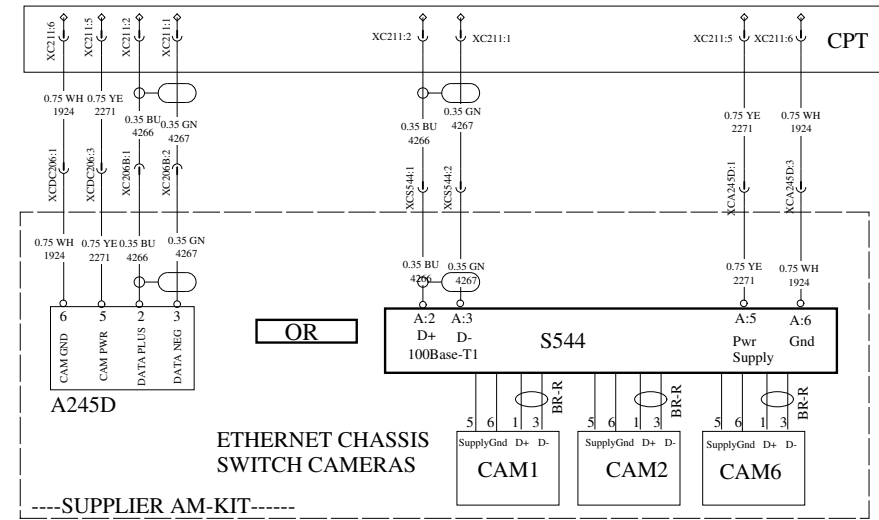

SINGLE CHASSIS AUX CAMERA AM PREP OR BOC CAMERA PREP

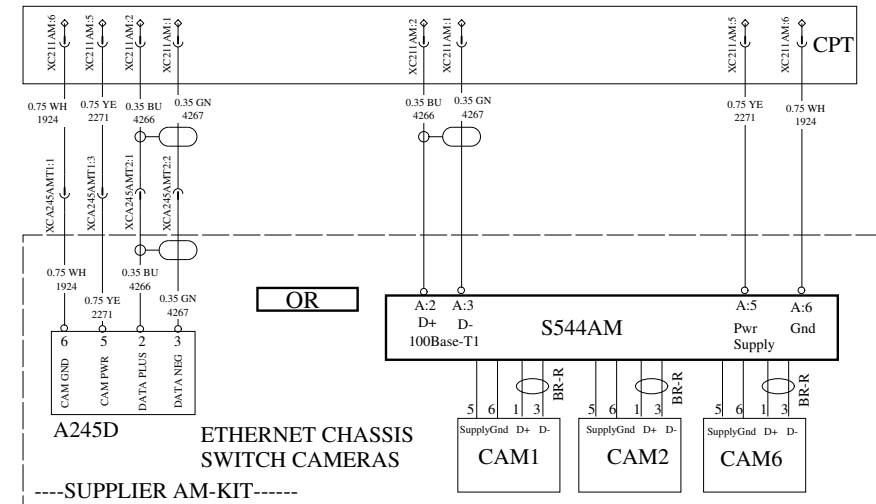

Document title
WIRING DIAGRAM, TEA2+ DIESEL

Legal Owner
Volvo Truck Corporation

Document No

24798720

Issue

01

Volume

1(1)

Page

72 (125)

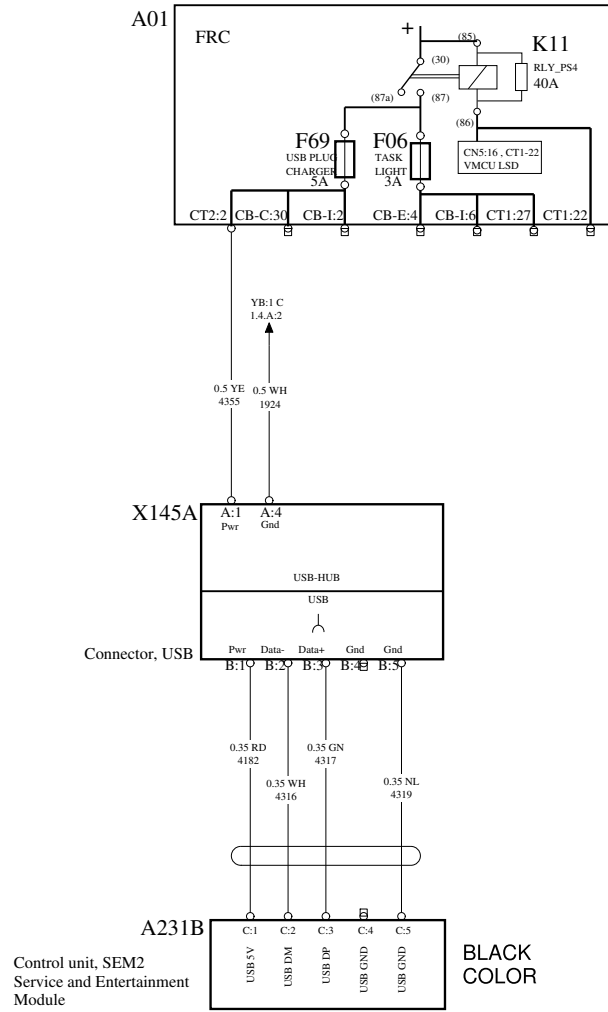

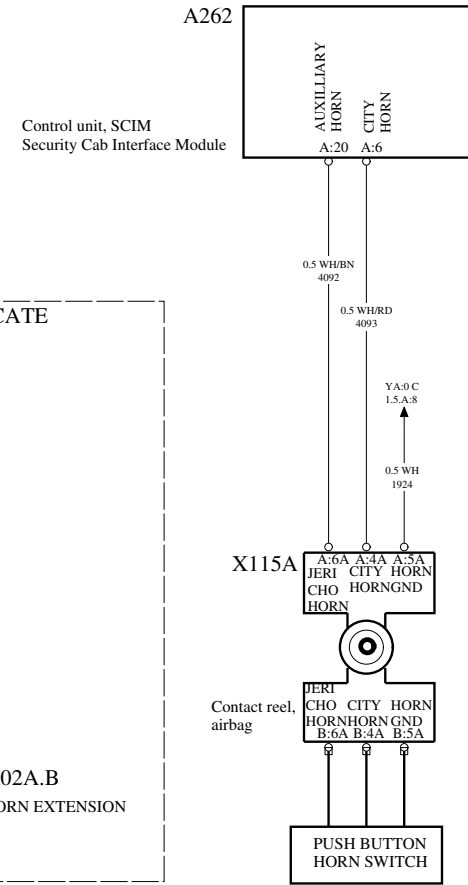
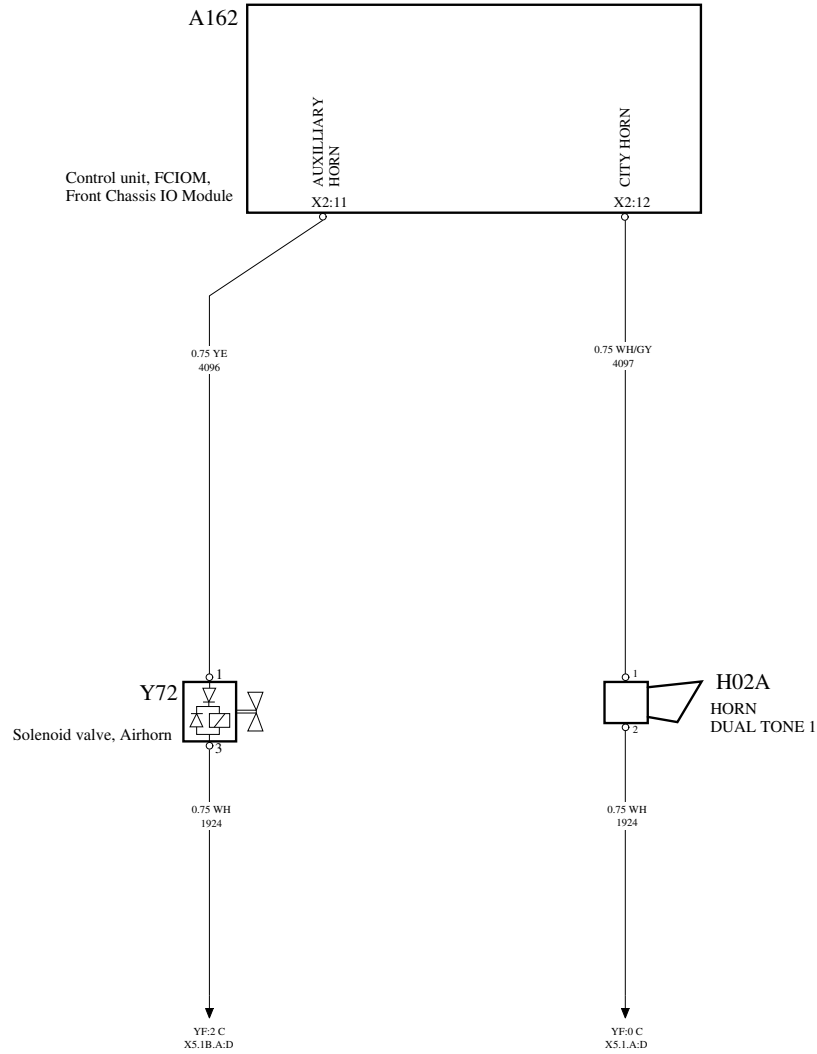

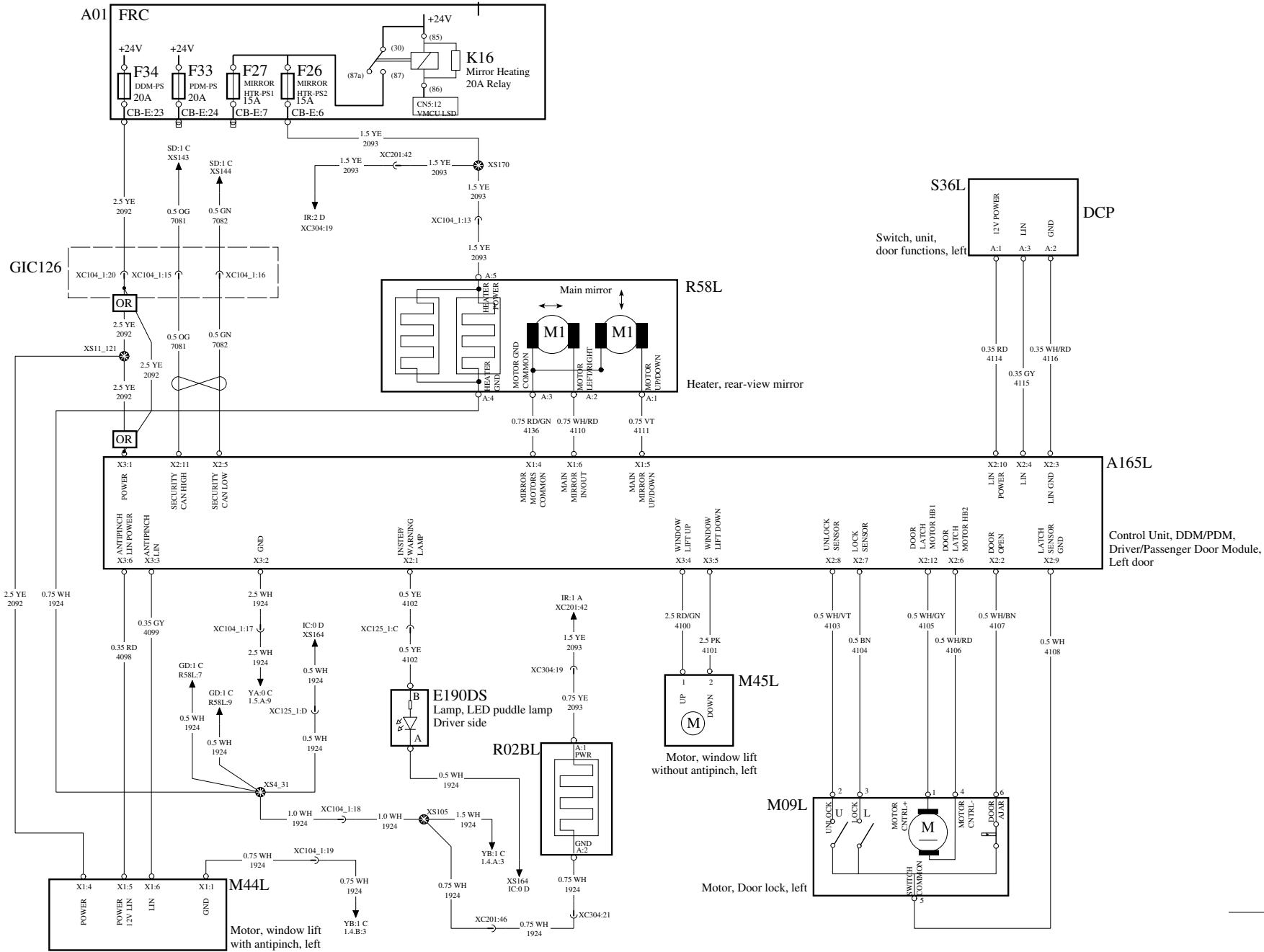

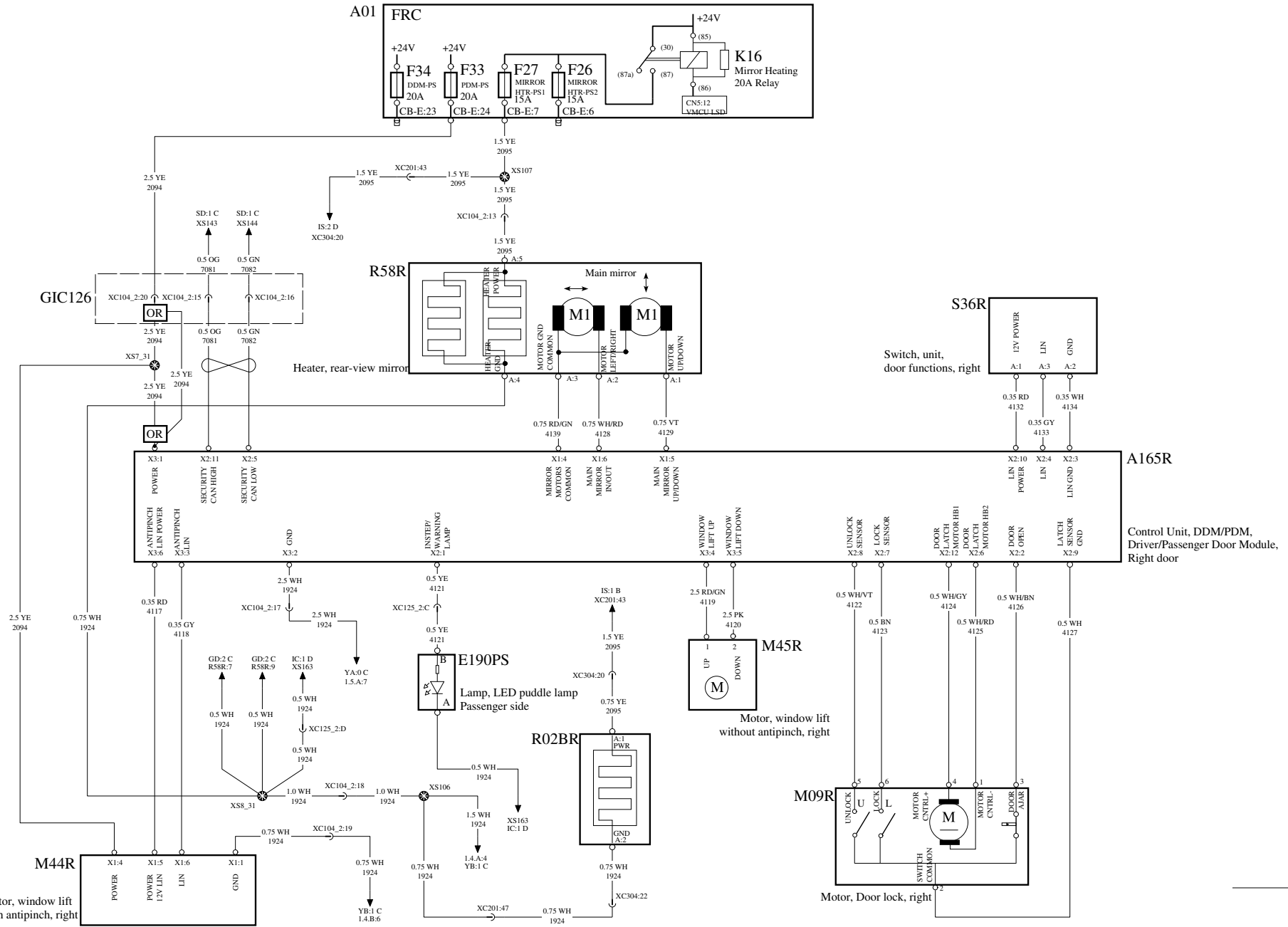

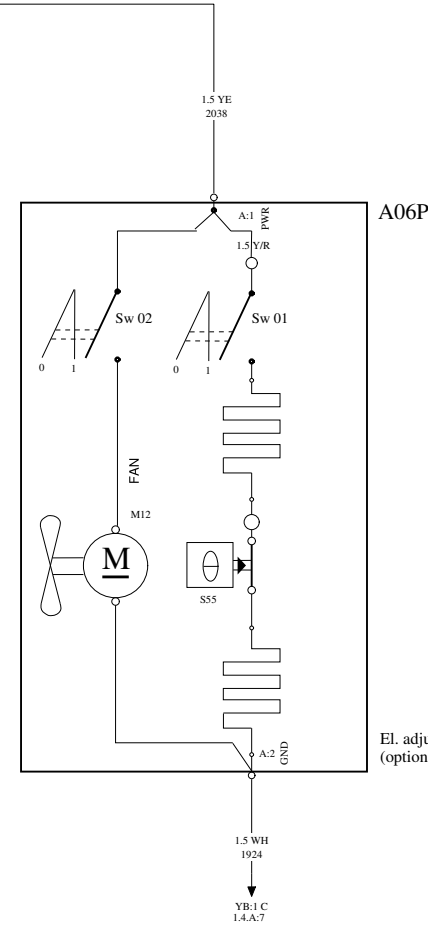
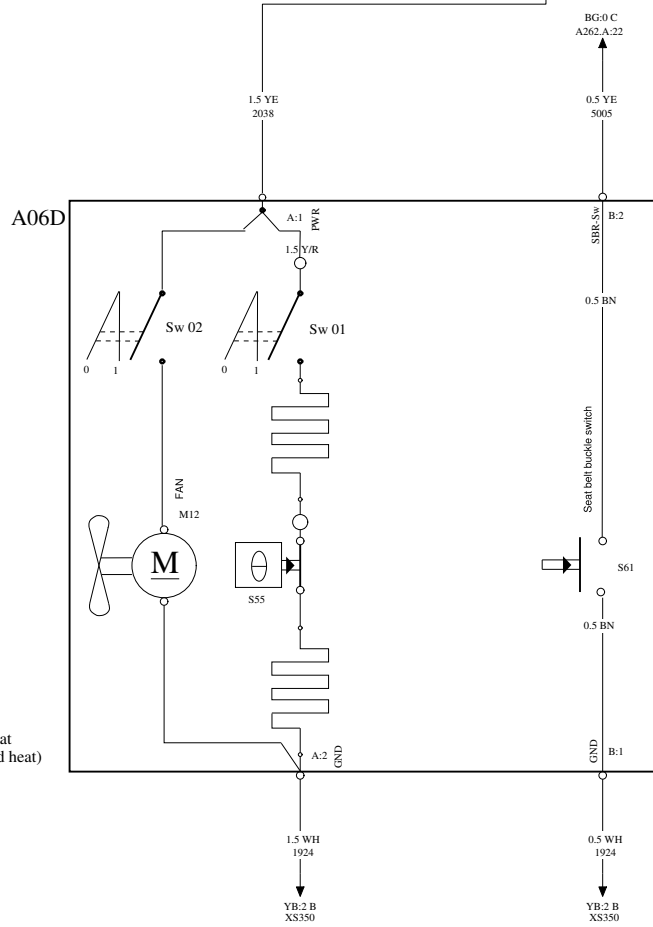
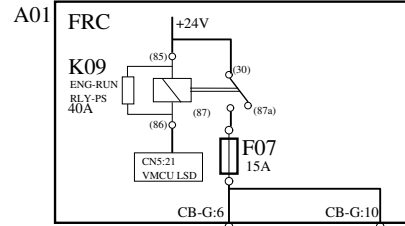

El. adjustable seat
(optional fan and heat)

El. adjustable seat
(optional fan and heat)

TPMS TIRE PRESSURE MONITORING SYSTEM WIRING DIAGRAM KC

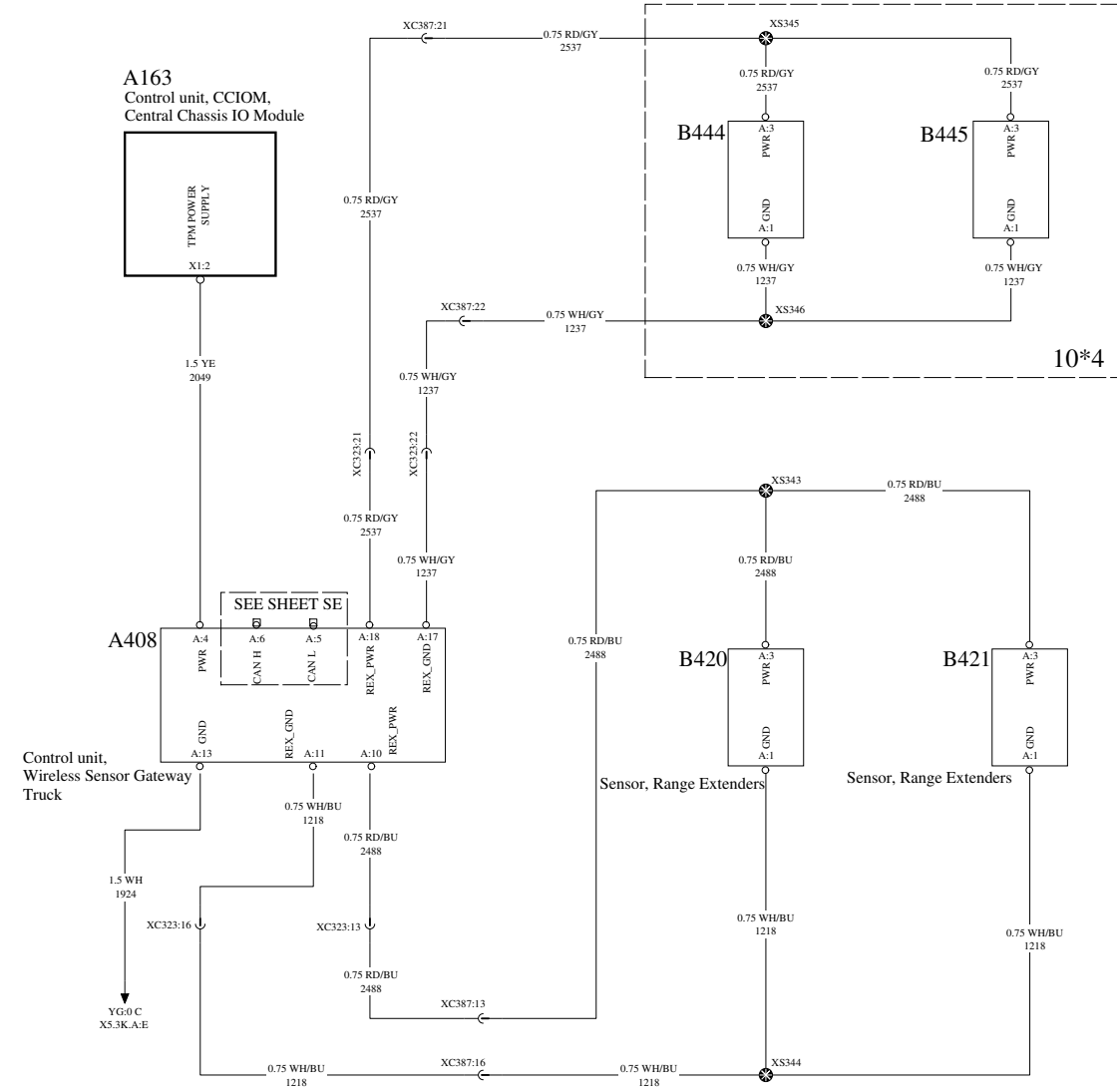

Document title WIRING DIAGRAM, TEA2+ DIESEL		Document No	Issue	Volume	Page
Legal Owner Volvo Truck Corporation		24798720	01	1(1)	78 (125)

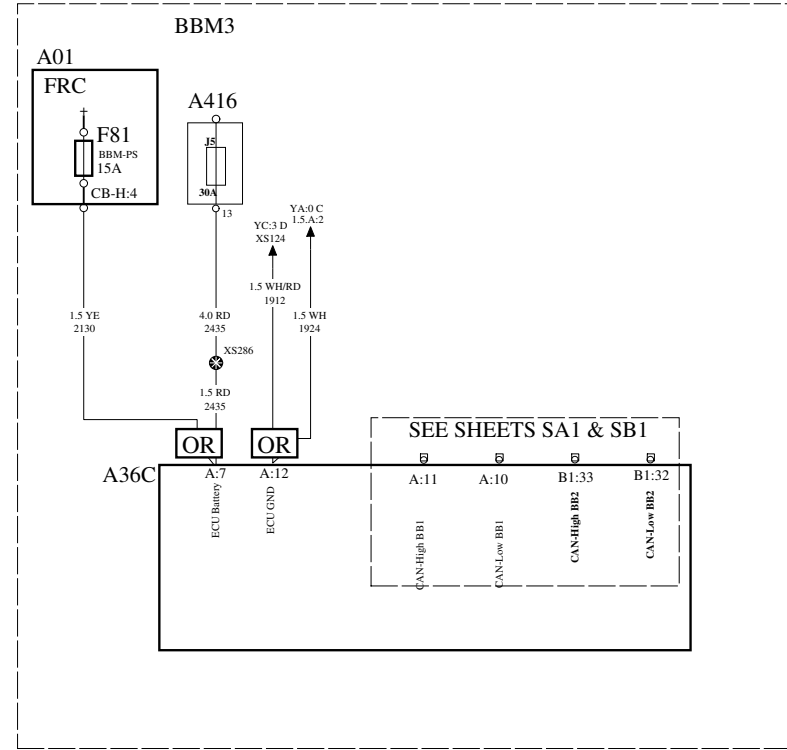
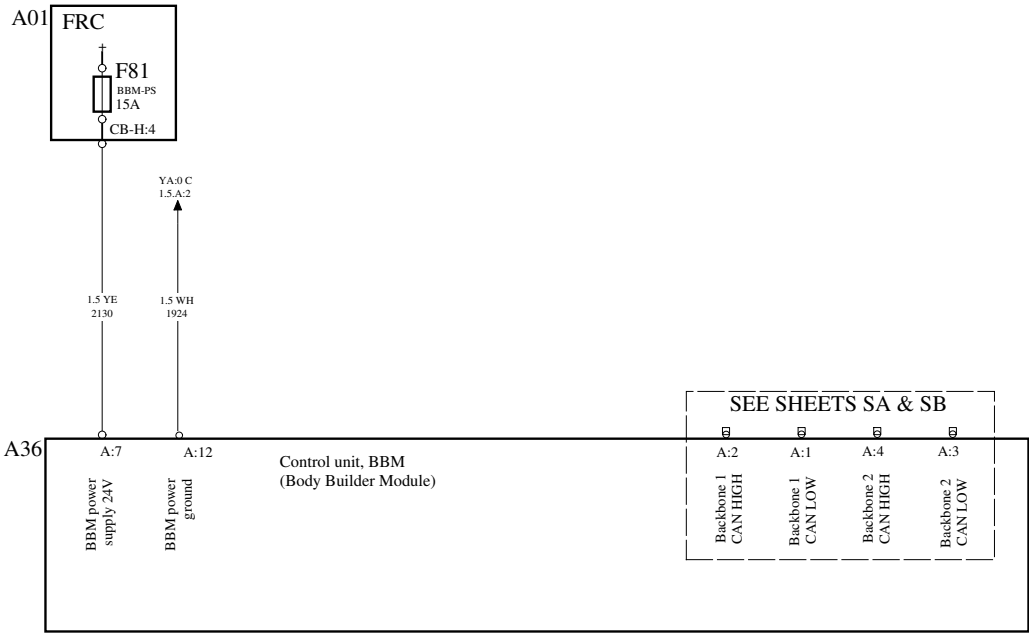

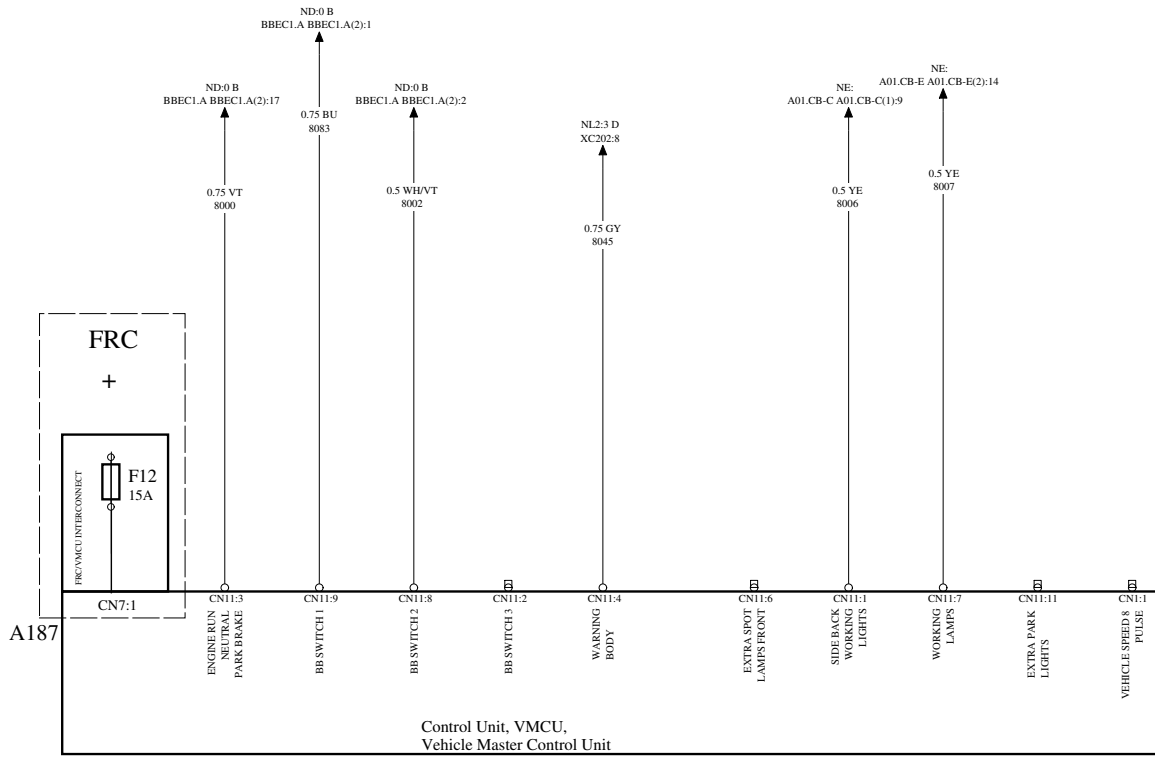

A163

Control unit, CCIOM,
Central Chassis IO Module

CCIOM

BBM- 5th Wheel

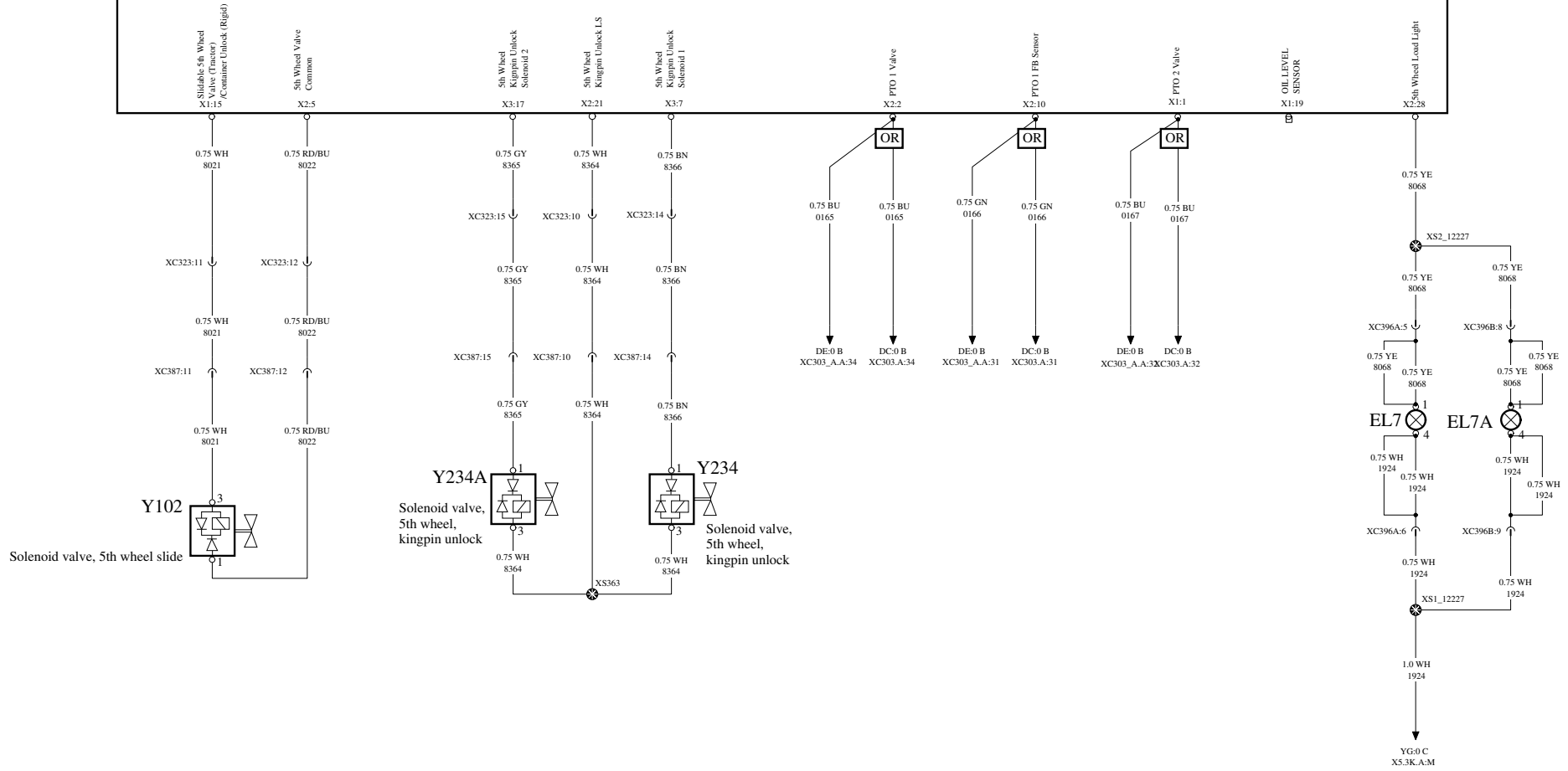

BODYBUILDER 12V BBEC

WIRING DIAGRAM ND

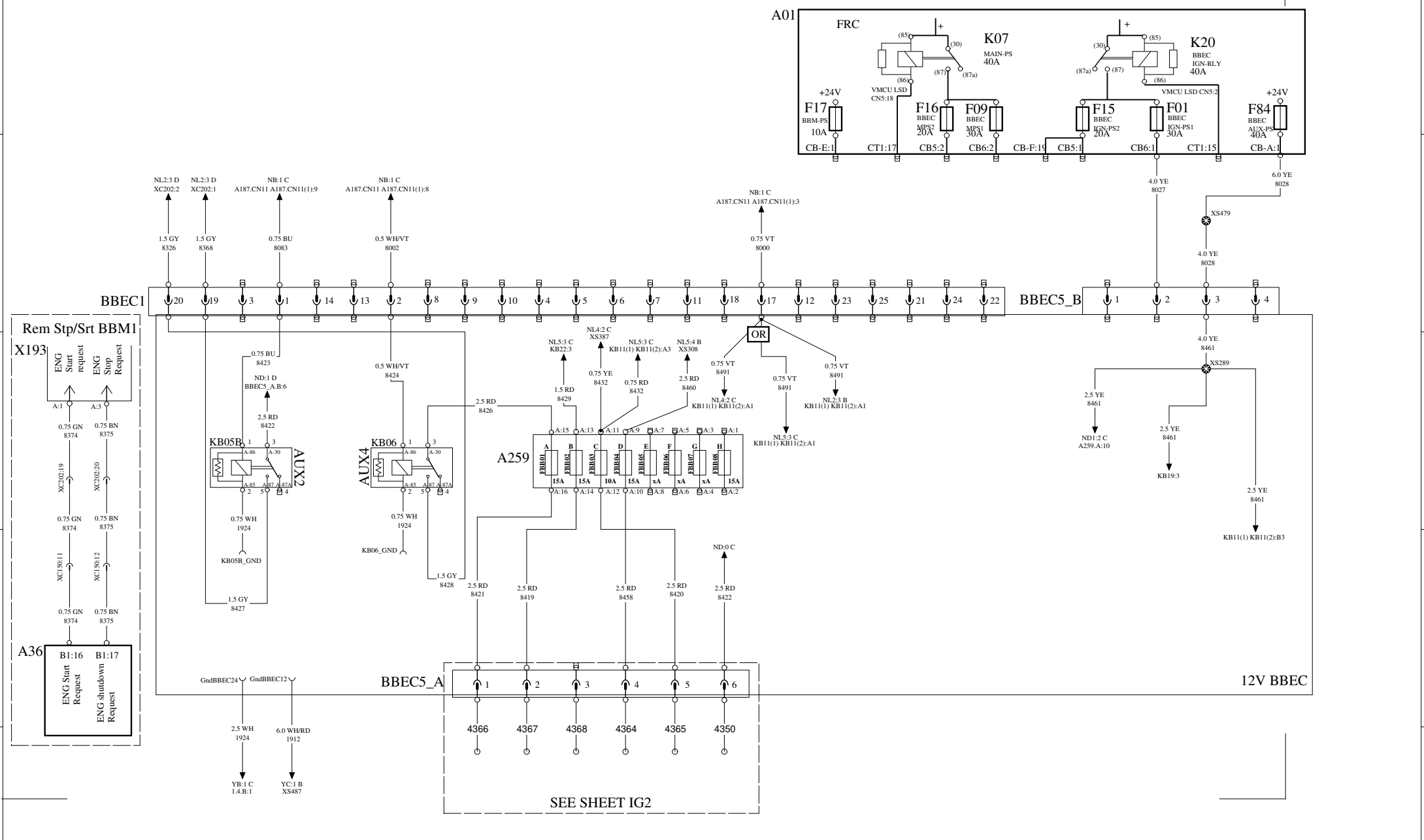

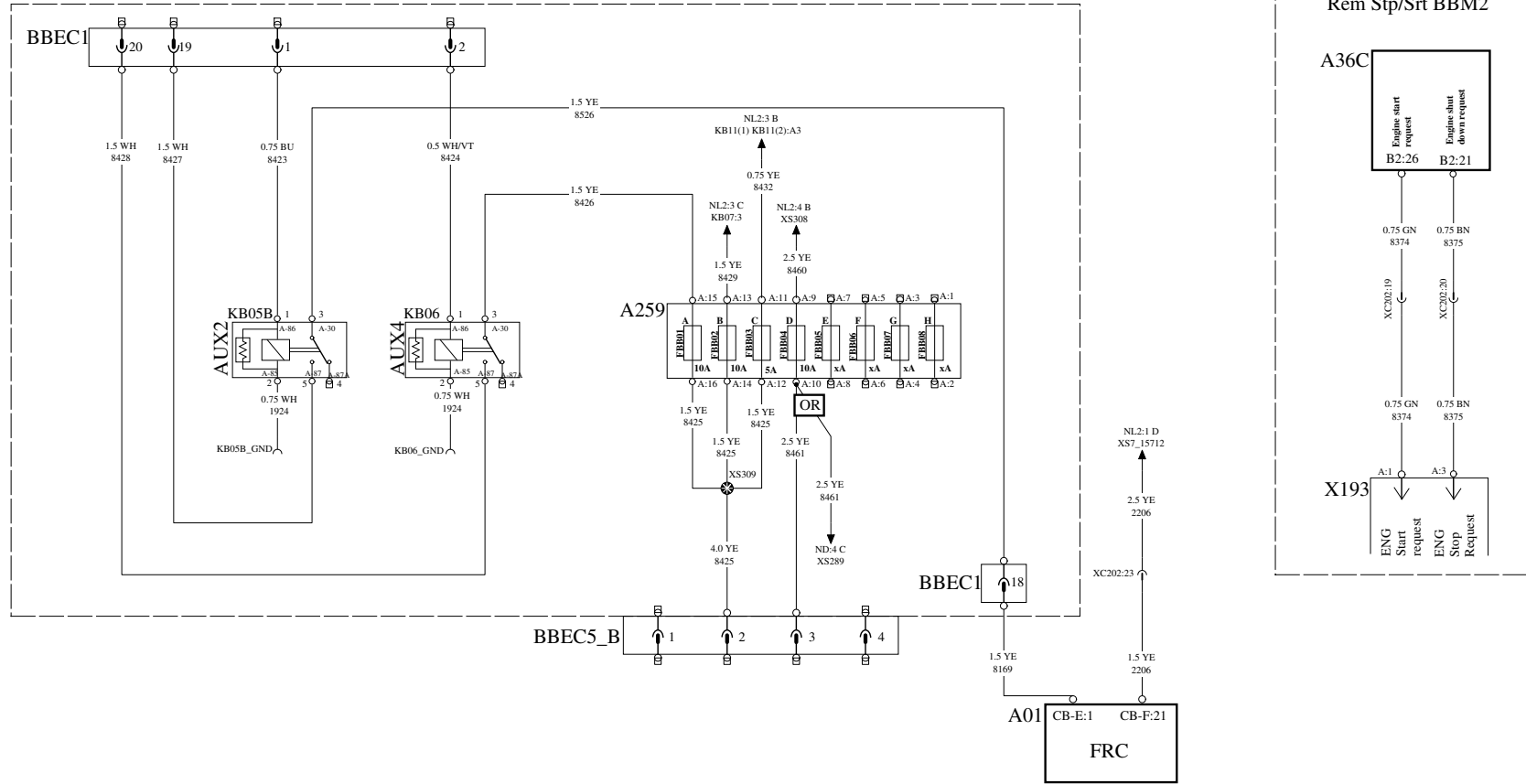

BODY BUILDER LIGHTS

WIRING DIAGRAM NE

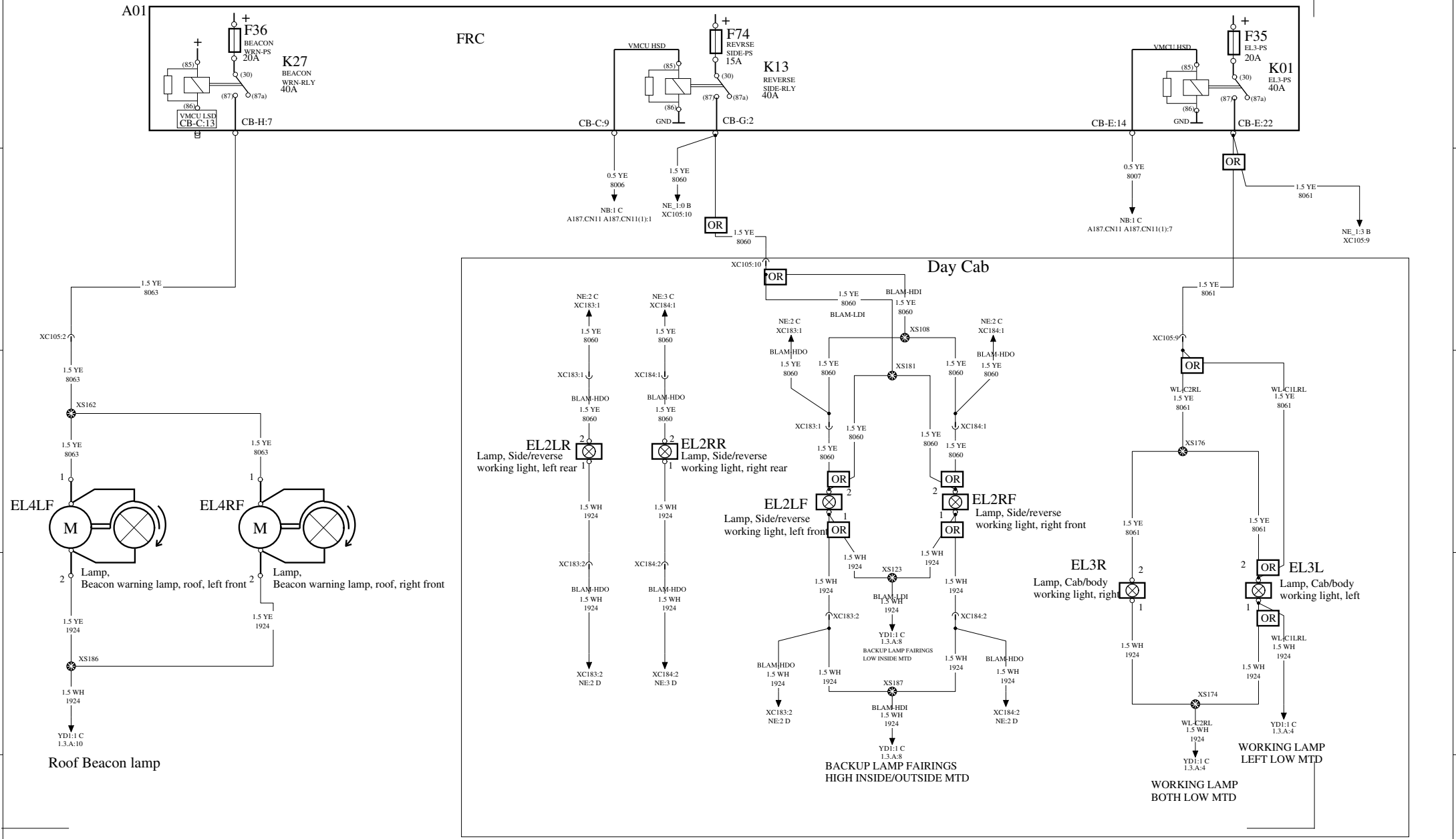

V O L V O

Document title
WIRING DIAGRAM, TEA2+ DIESEL
 Legal Owner
 Volvo Truck Corporation

Document No

24798720

Issue

01

Volume

1(1)

Page

84 (125)

SLEEPER

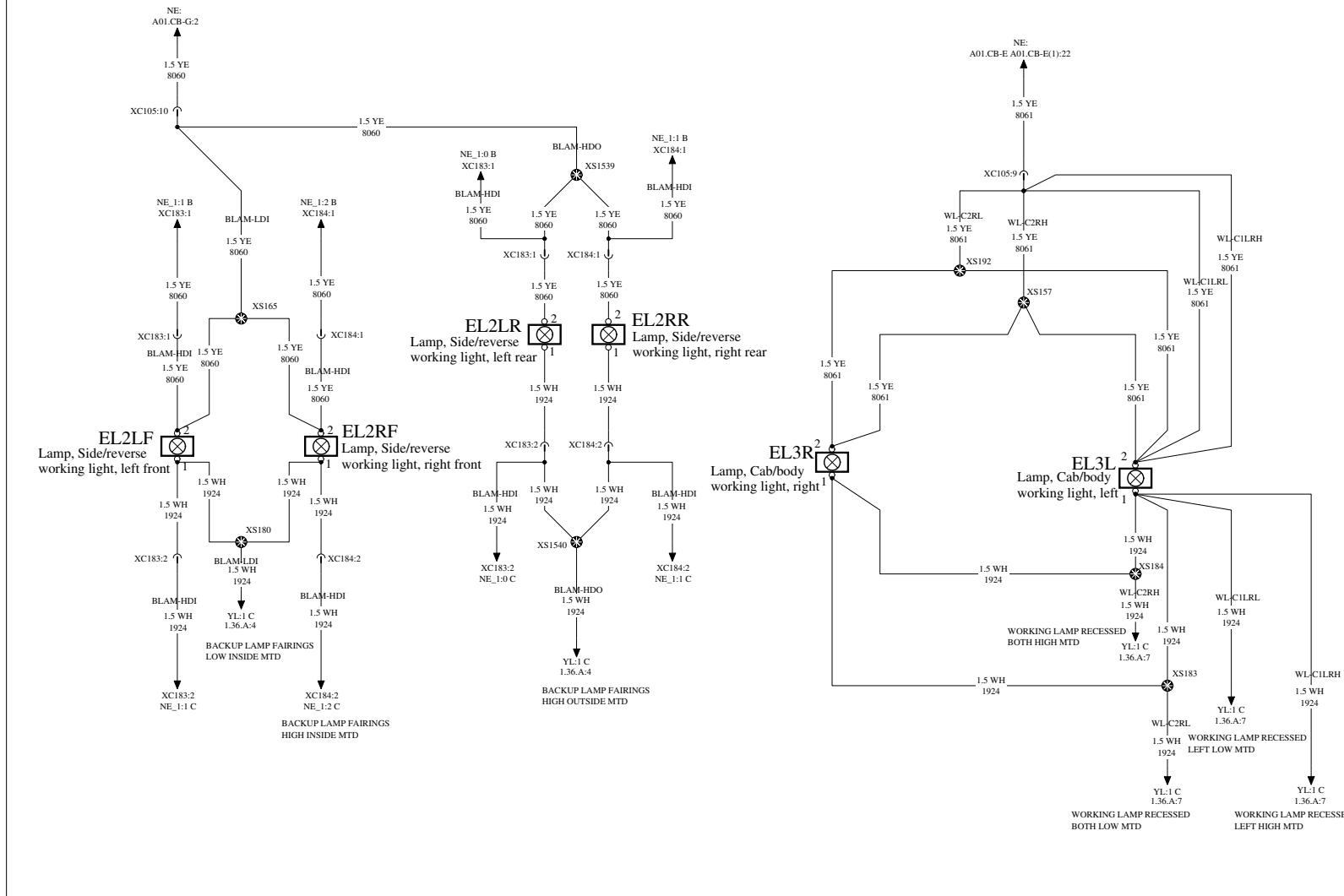

BODY BUILDER 12V AUX SWITCHES

WIRING DIAGRAM NF

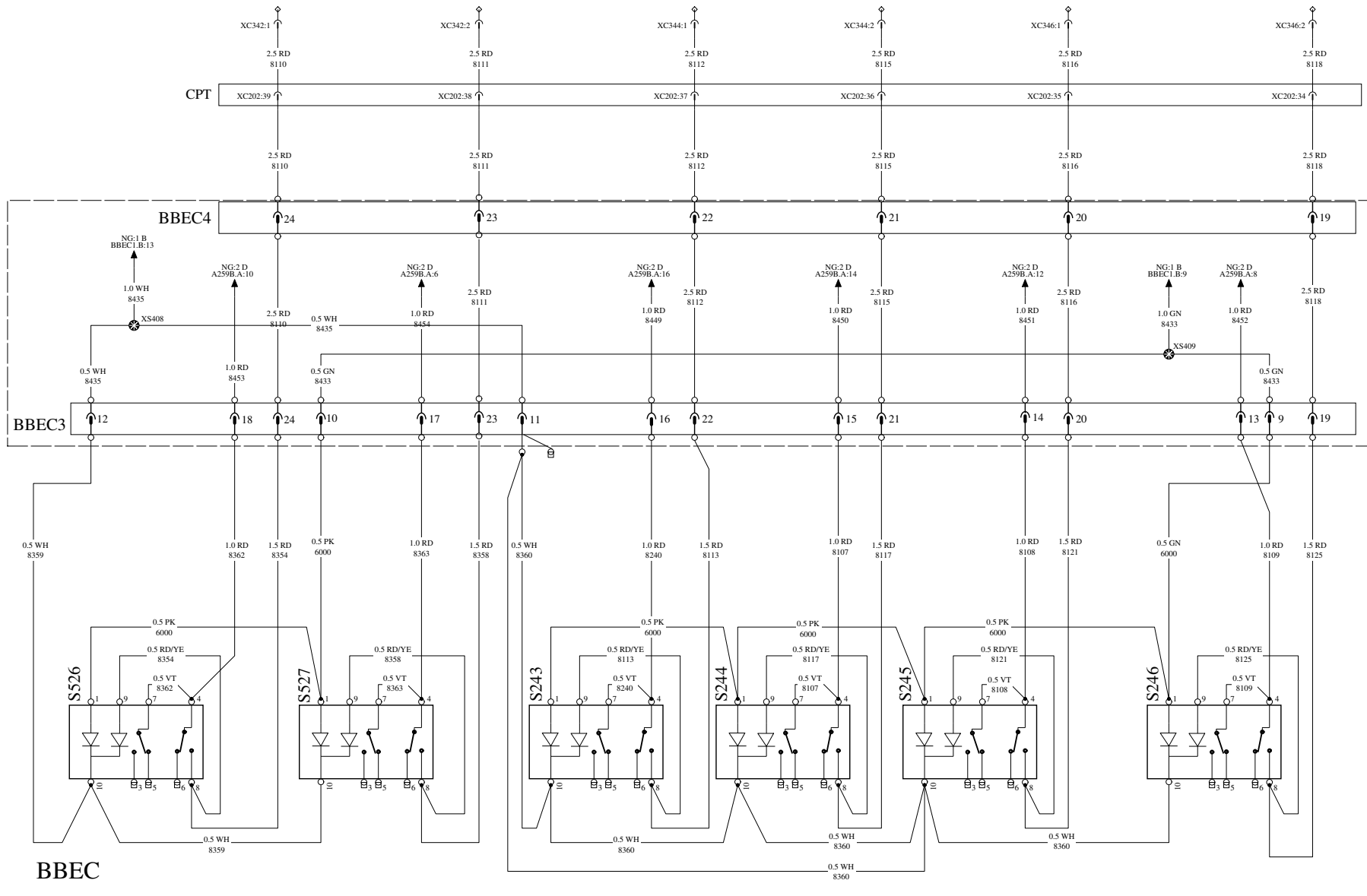

V O L V O

Document title
WIRING DIAGRAM, TEA2+ DIESEL
 Legal Owner
 Volvo Truck Corporation

Document No

24798720

Issue

01

Volume

1(1)

Page

86 (125)

BODYBUILDER 24V AUX SWITCHES

WIRING DIAGRAM NF1

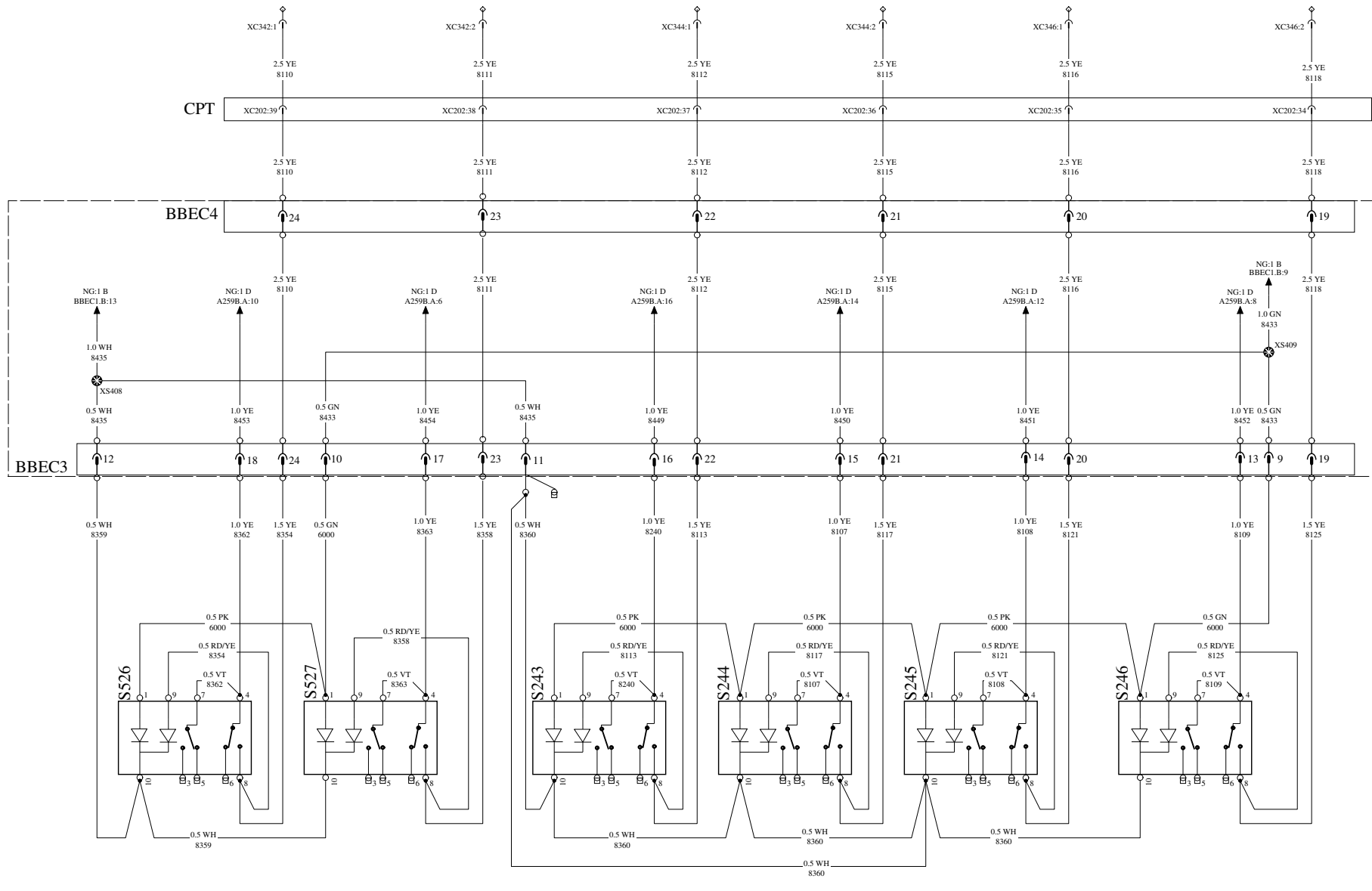

V O L V O

Document title
WIRING DIAGRAM, TEA2+ DIESEL
 Legal Owner
Volvo Truck Corporation

Document No
24798720

Issue
01

Volume
1(1)

Page
87 (125)

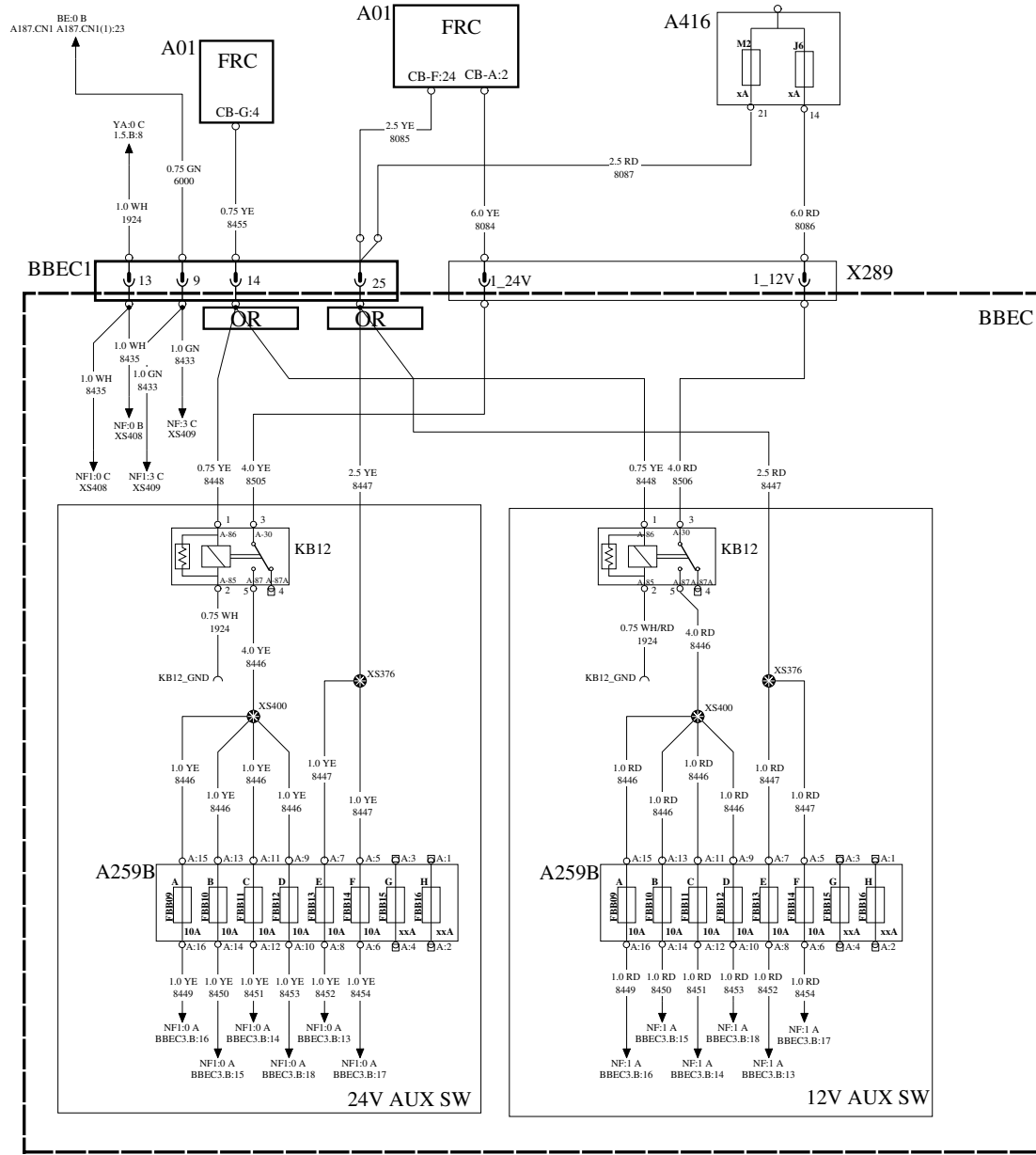

BODYBUILDER COMMON INTERFACE

BB TRANS INTERFACE

WIRING DIAGRAM NI

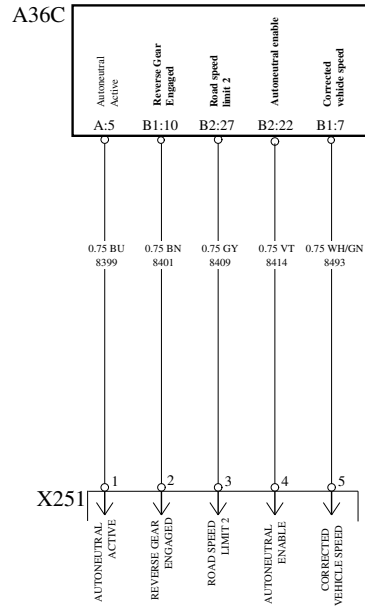

Document title
WIRING DIAGRAM, TEA2+ DIESEL

Document No

Issue

Volume

Page

Legal Owner
Volvo Truck Corporation

24798720

01

1(1)

89 (125)

BODYBUILDER 24V BODYLINK

24V BBCHAS4

WIRING DIAGRAM NL2

A163

Control unit, CCIOM,
Central Chassis IO Module



A36C

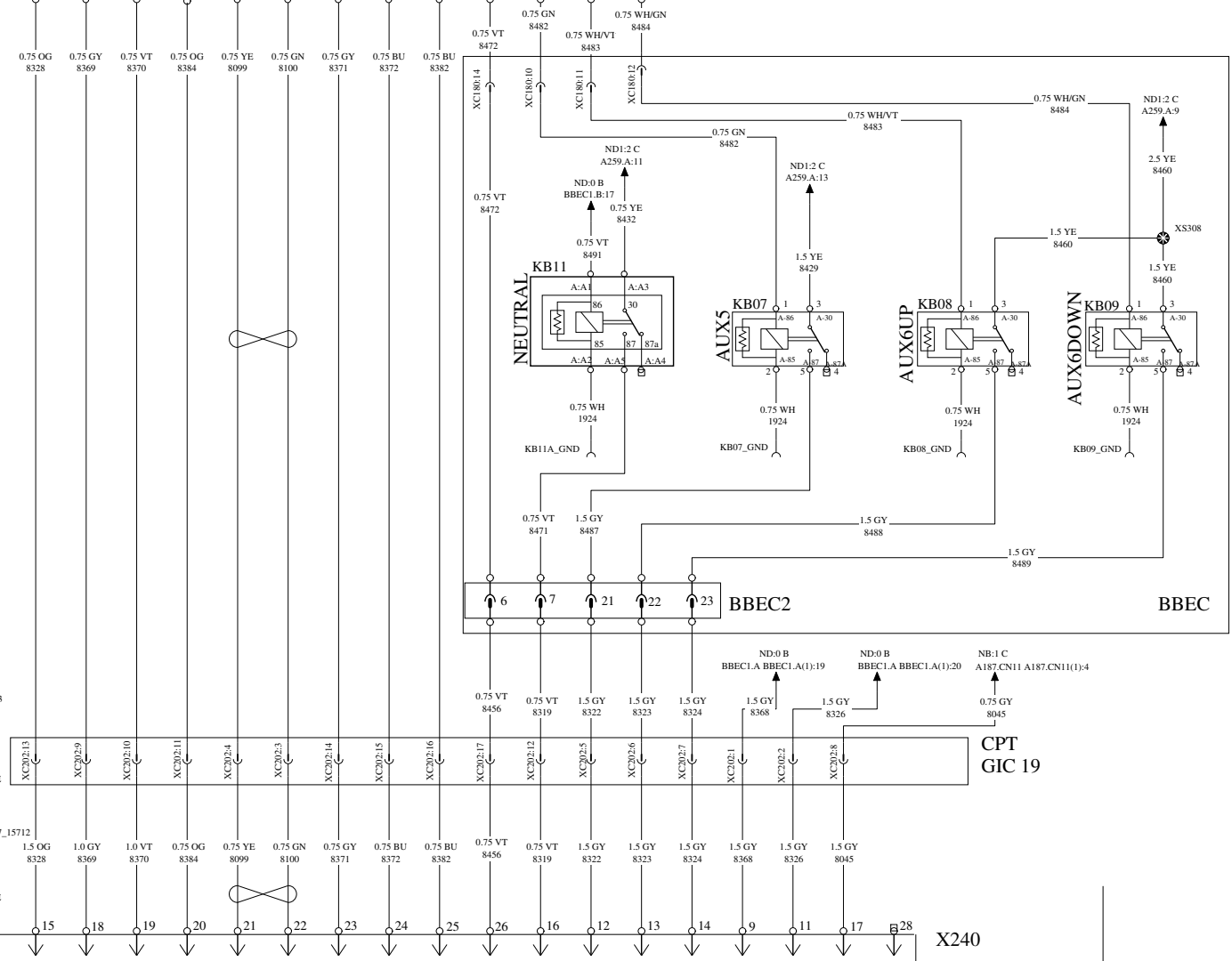
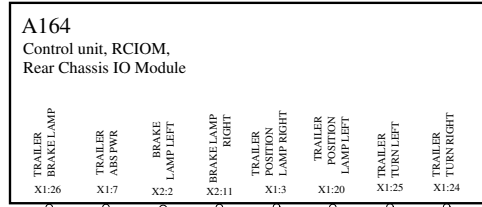
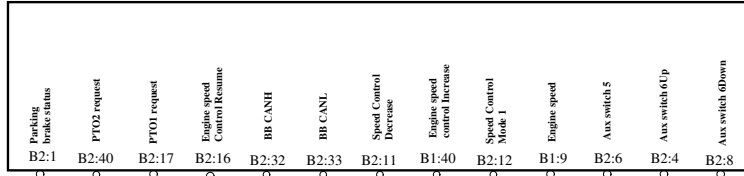

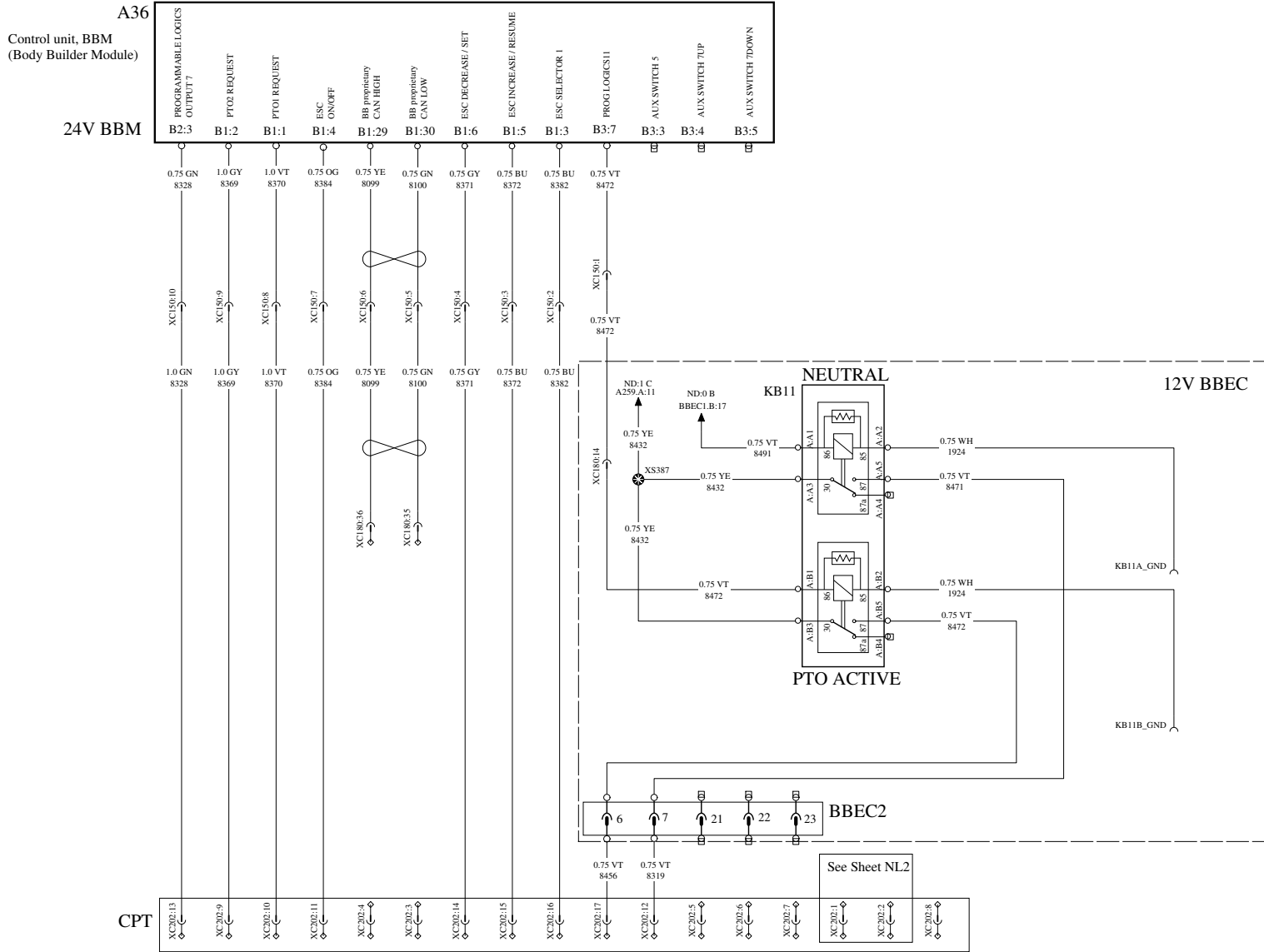

A36C

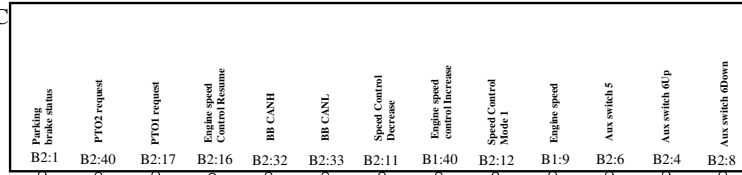

A269
Control Unit,
Trailer Body Builder
Input/Output Module.

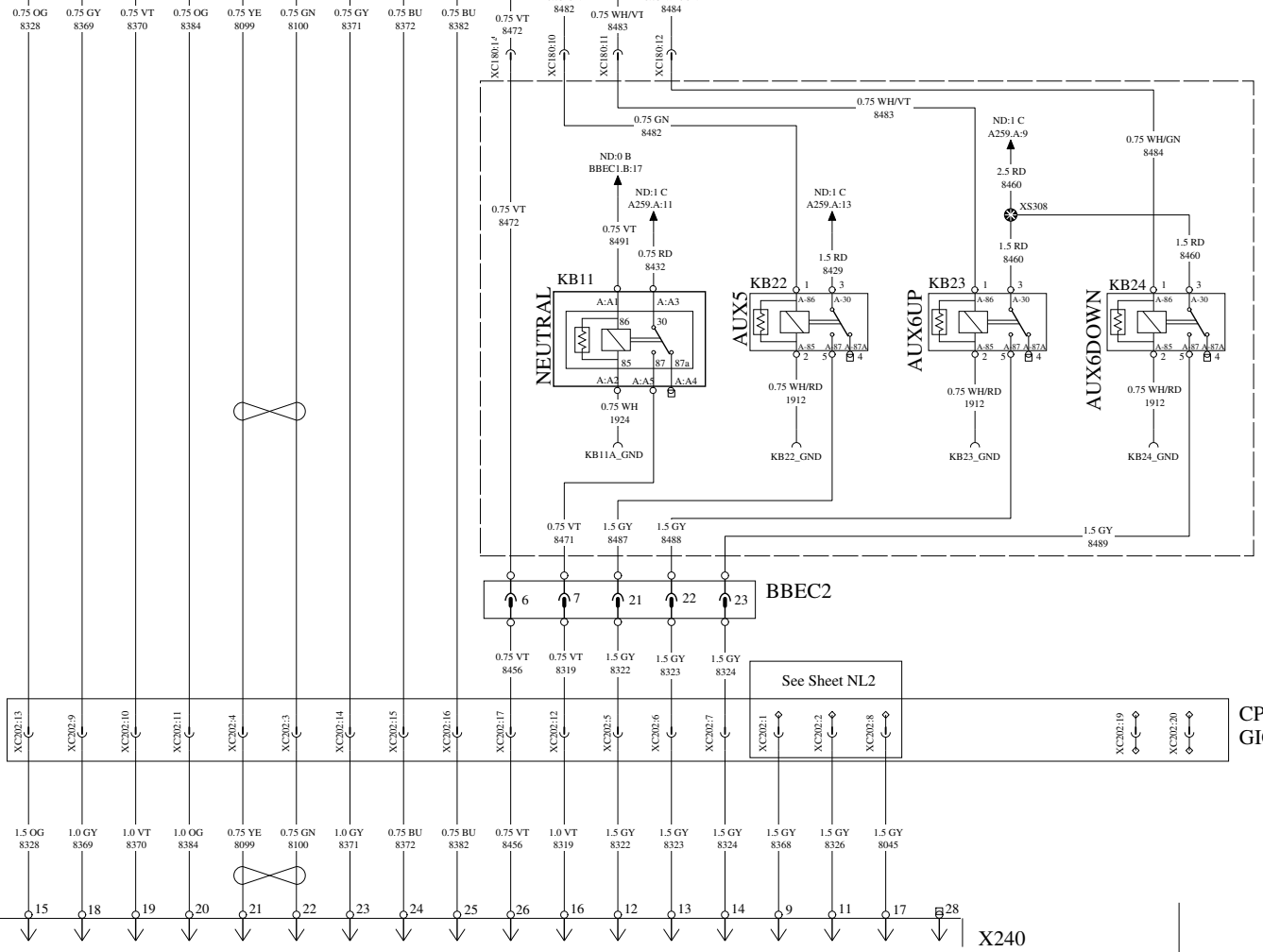
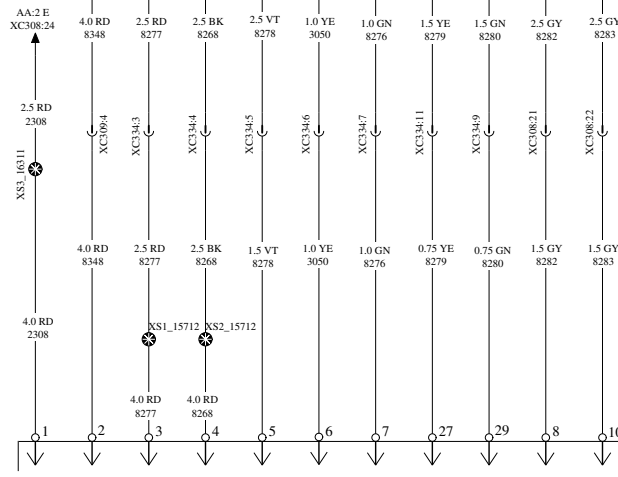
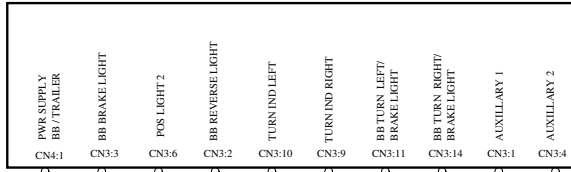

BODYBUILDER 12V RP170

WIRING DIAGRAM NM

A269

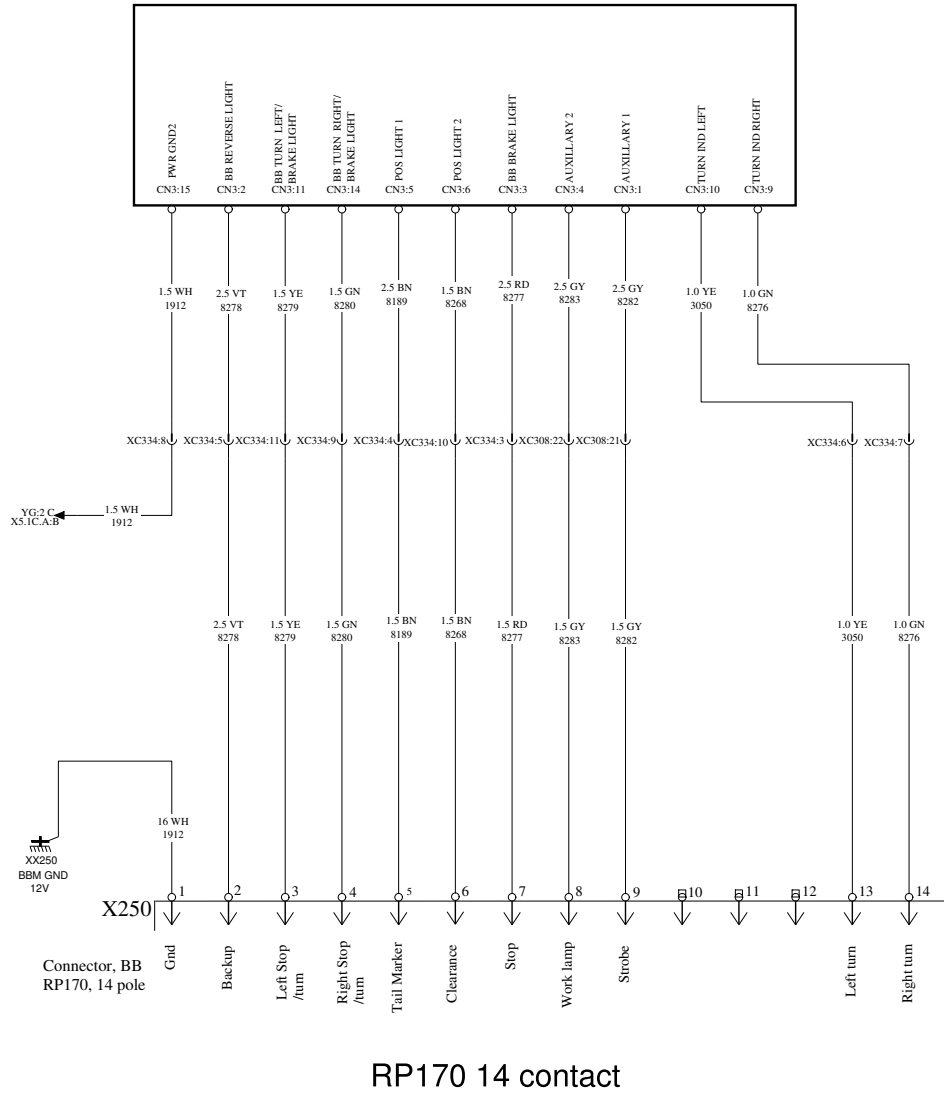

RP170 14 contact

A269AM

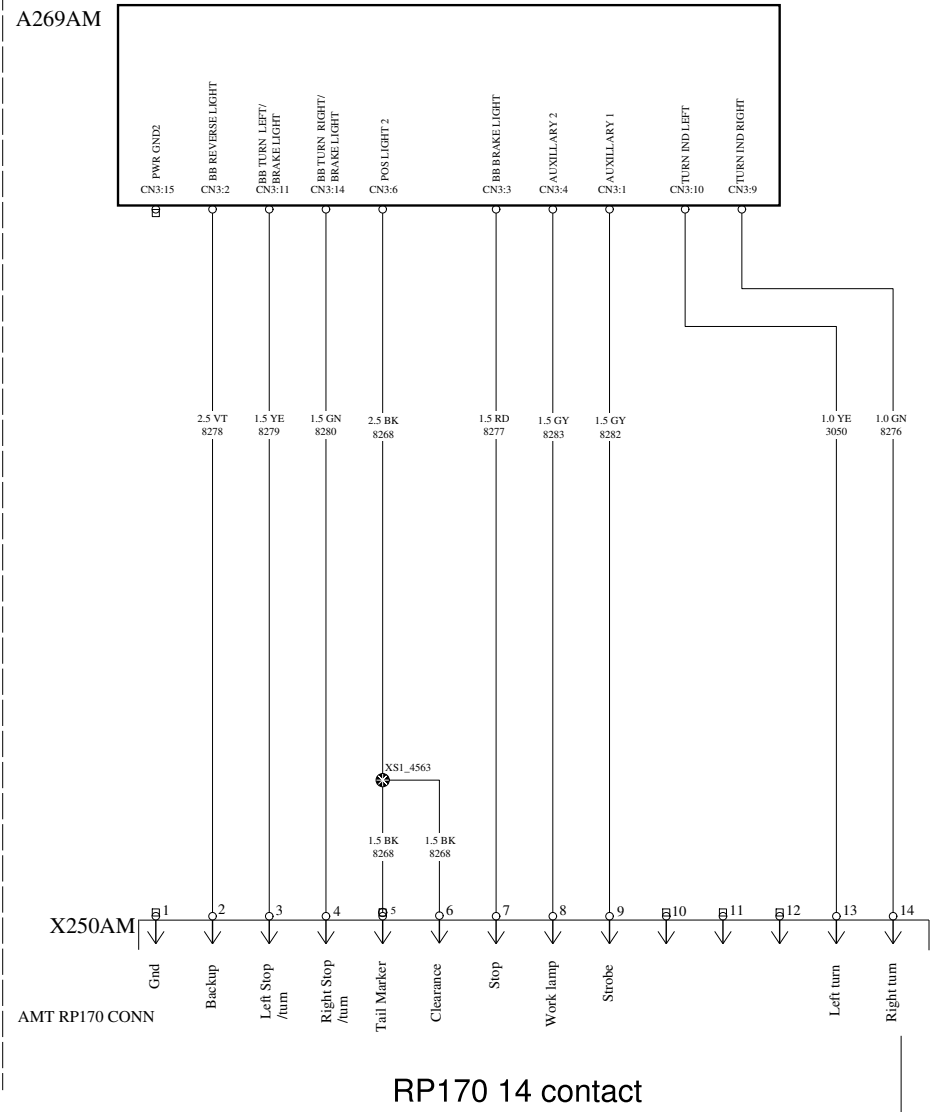

RP170 14 contact

BODYBUILDER TRAILER

TBIOM, 12V TRACTOR

WIRING DIAGRAM NT

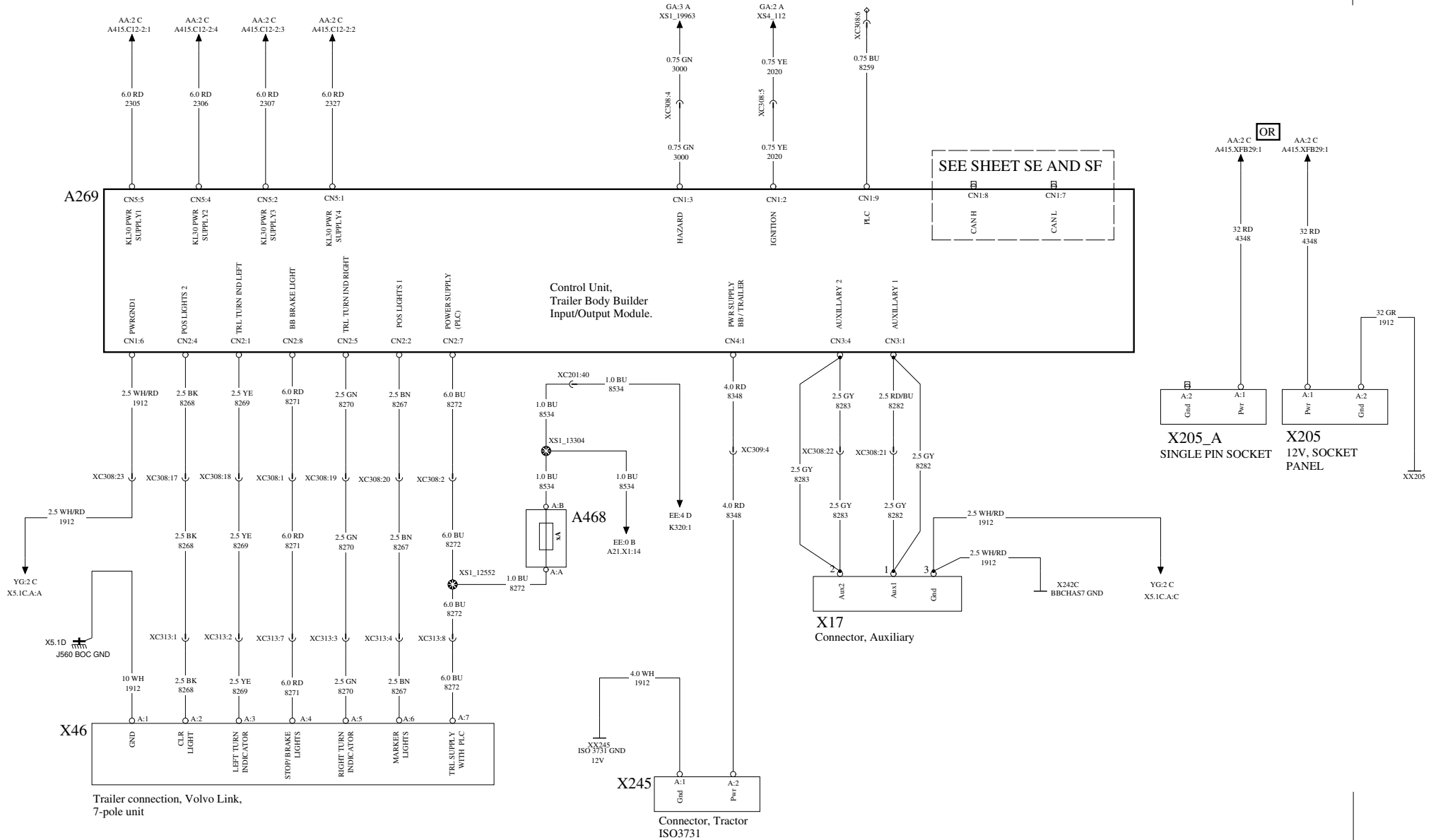

SEE SHEET SE AND SF

X205_A SINGLE PIN SOCKET
X205 12V, SOCKET PANEL

X17 Connector, Auxiliary

X245 Connector, Tractor ISO3731

Trailer connection, Volvo Link, 7-pole unit



Document title
WIRING DIAGRAM, TEA2+ DIESEL
Legal Owner
Volvo Truck Corporation

Document No	Issue	Volume	Page
24798720	01	1(1)	94 (125)

BODYBUILDER TRAILER

BOC AND EOF

WIRING DIAGRAM NT1

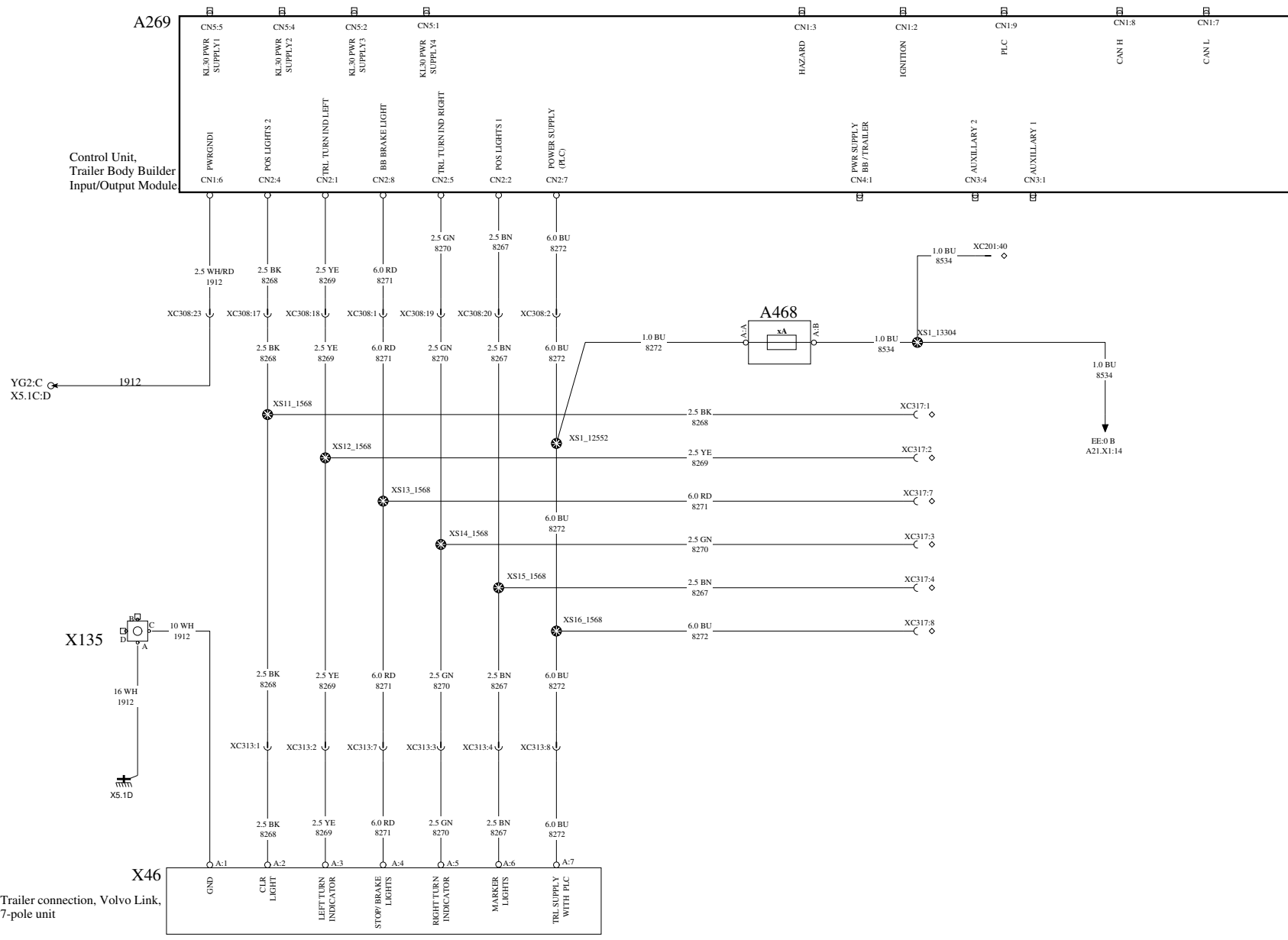

Document title
WIRING DIAGRAM, TEA2+ DIESEL
 Legal owner
Volvo Truck Corporation

Document No

24798720

Issue

01

Volume

1(1)

Page

95 (125)

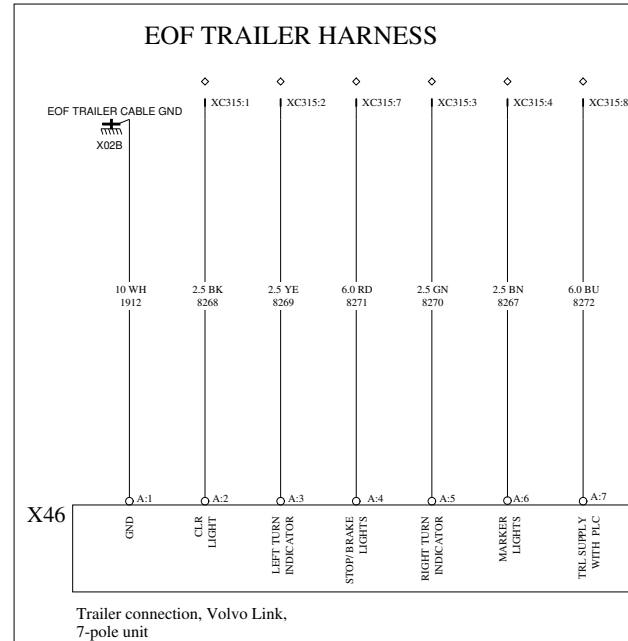
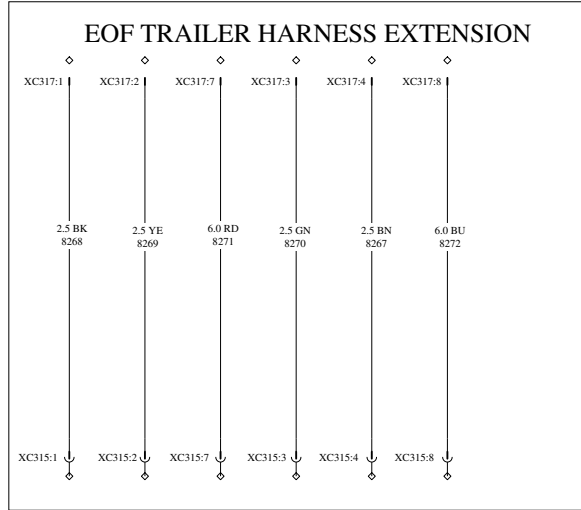

DRIVER ASSISTANCE CONTROL UNIT

DACU3.2

WIRING DIAGRAM PA

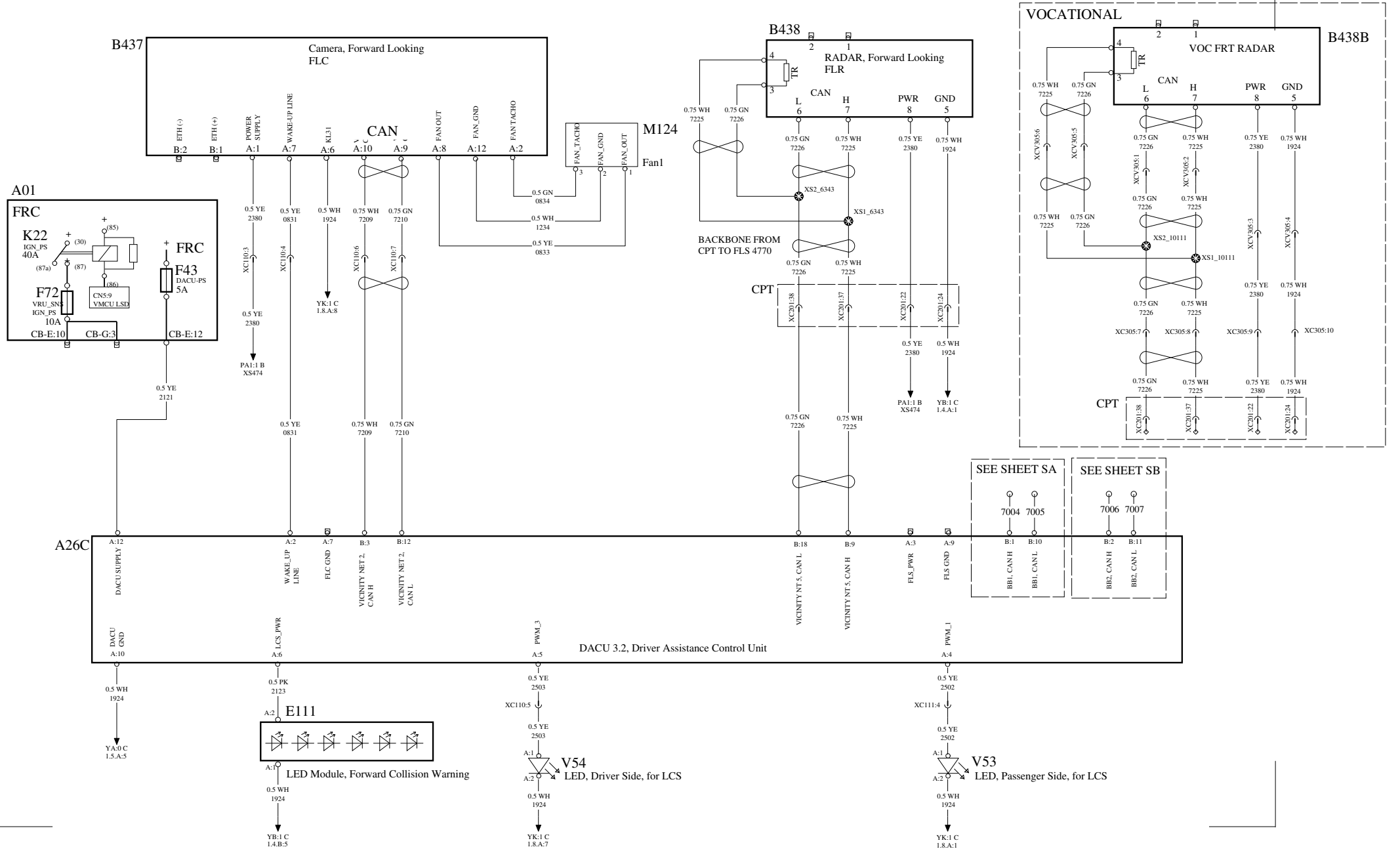

Document title
WIRING DIAGRAM, TEA2+ DIESEL

Legal Owner
Volvo Truck Corporation

Document No
24798720

Issue	Volume	Page
01	1(1)	97 (125)

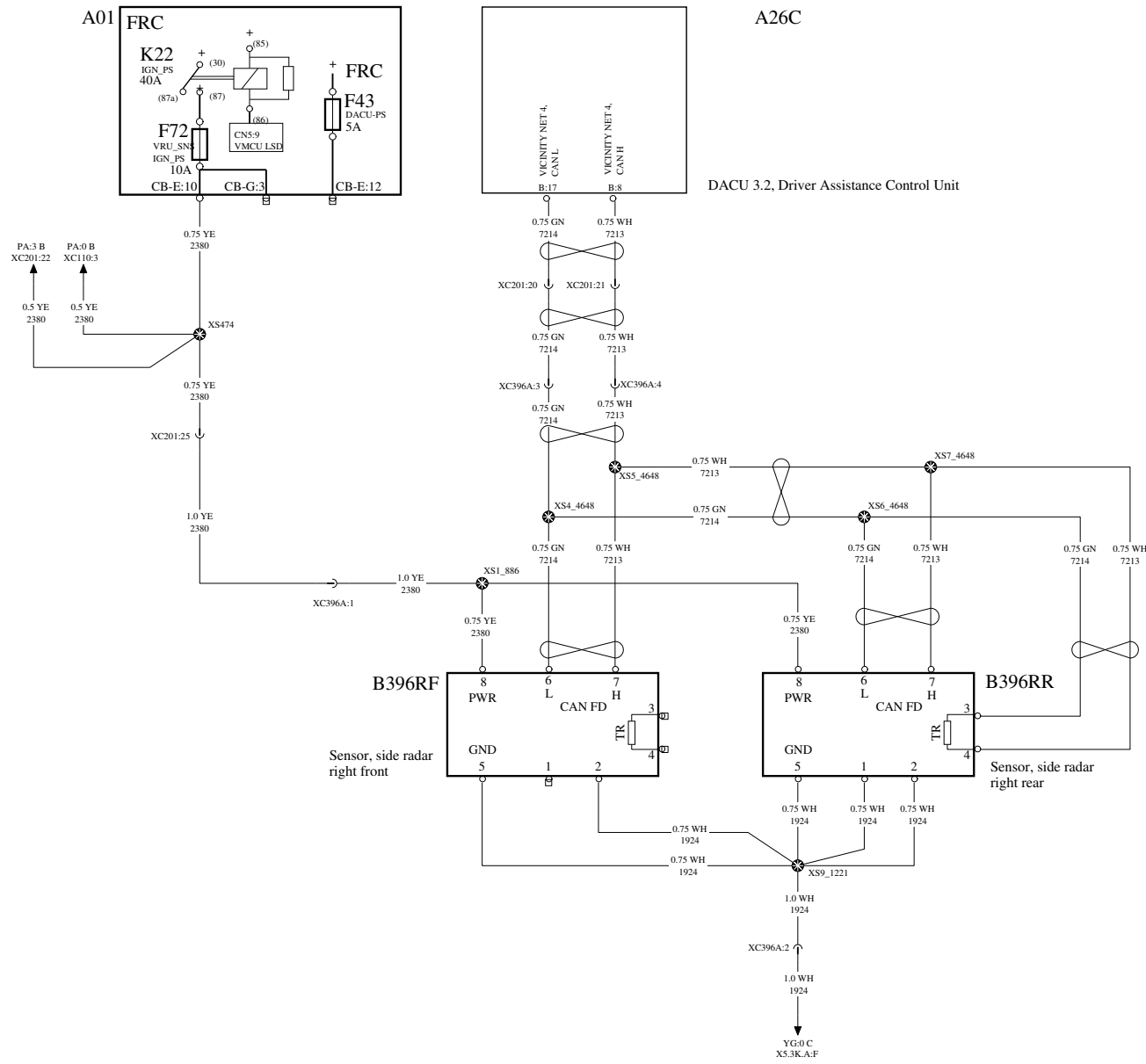

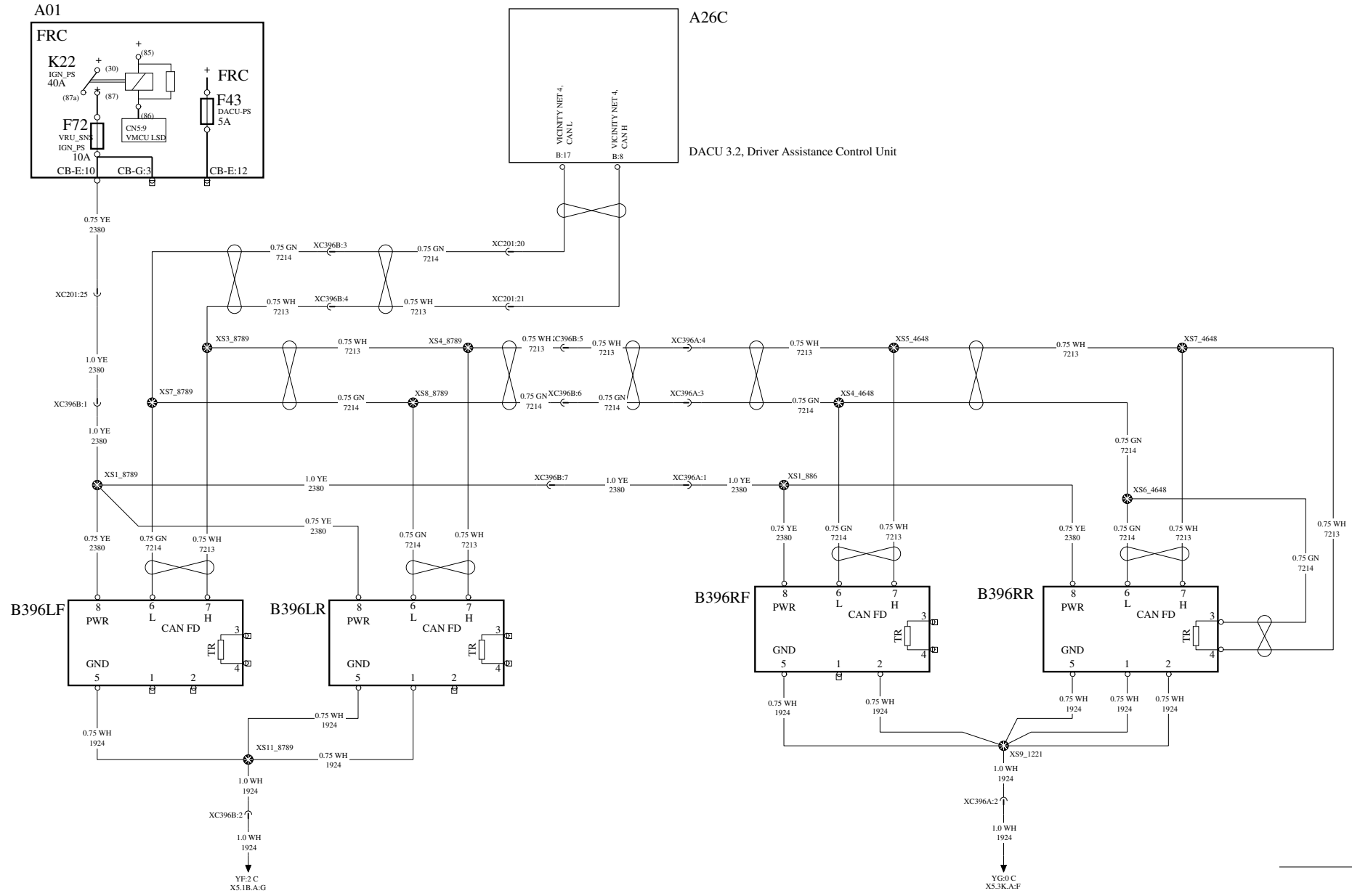

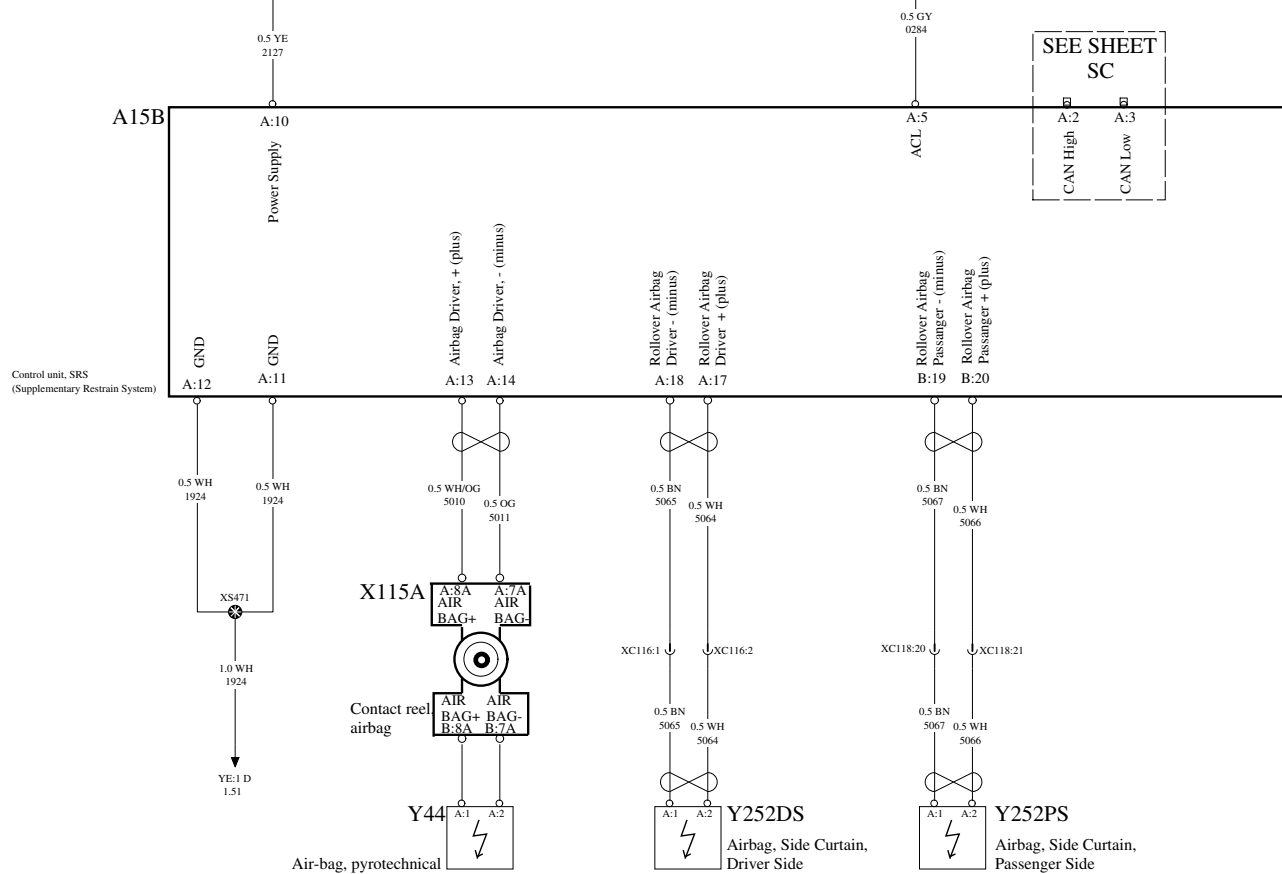
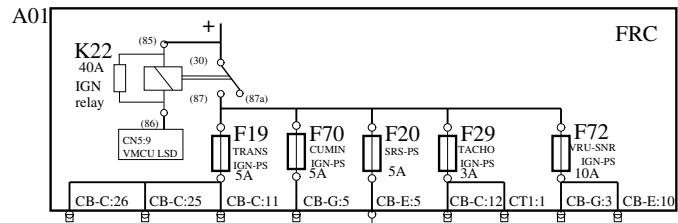

SEE SHEET SC

A:2 CAN High

A:3 CAN Low



VOLVO	Document title WIRING DIAGRAM, TEA2+ DIESEL		Document No 24798720	Issue 01	Volume 1(1)	Page 100 (125)
	Legal Owner Volvo Truck Corporation					

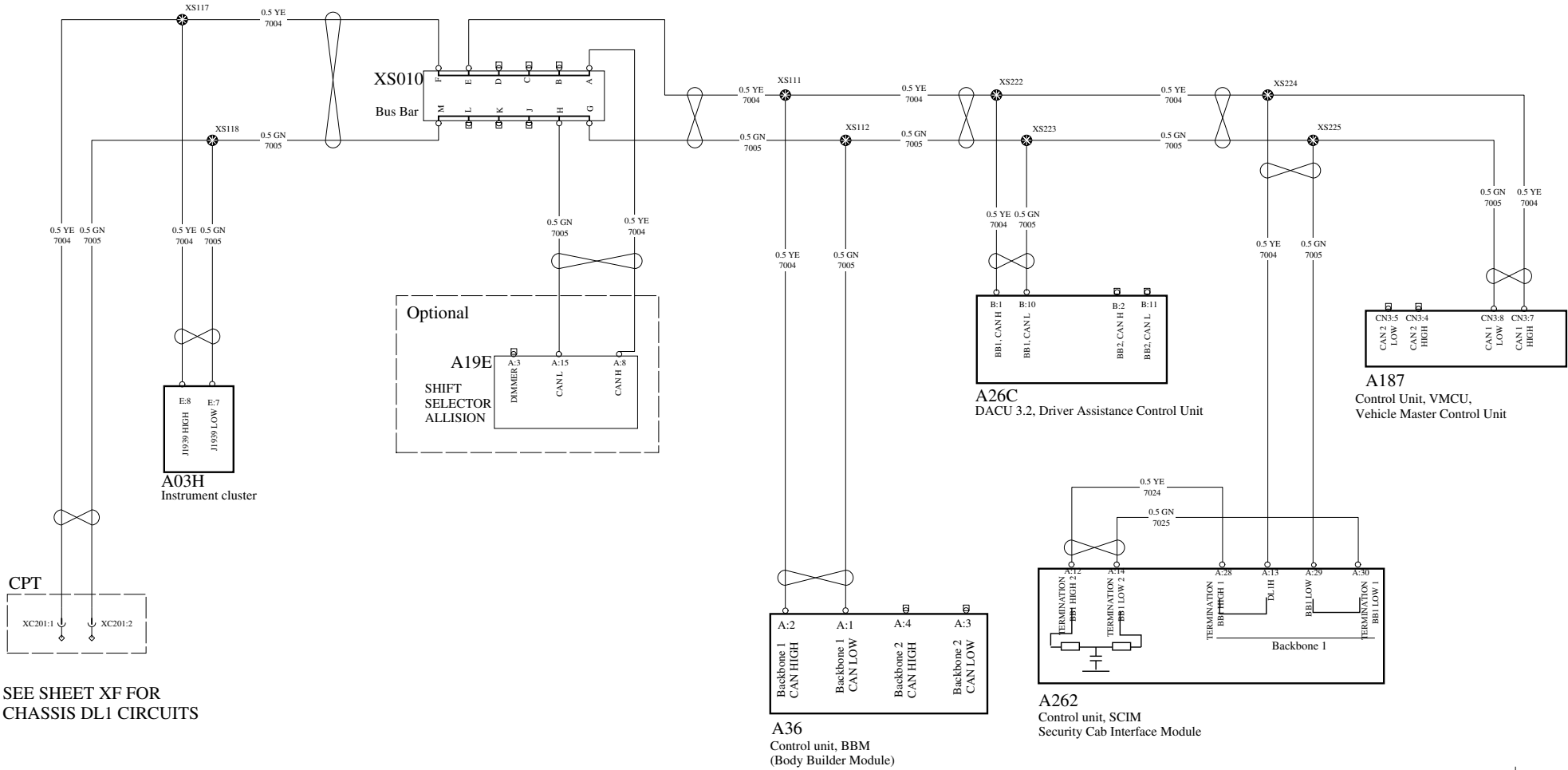

SEE SHEET XF FOR CHASSIS DL1 CIRCUITS

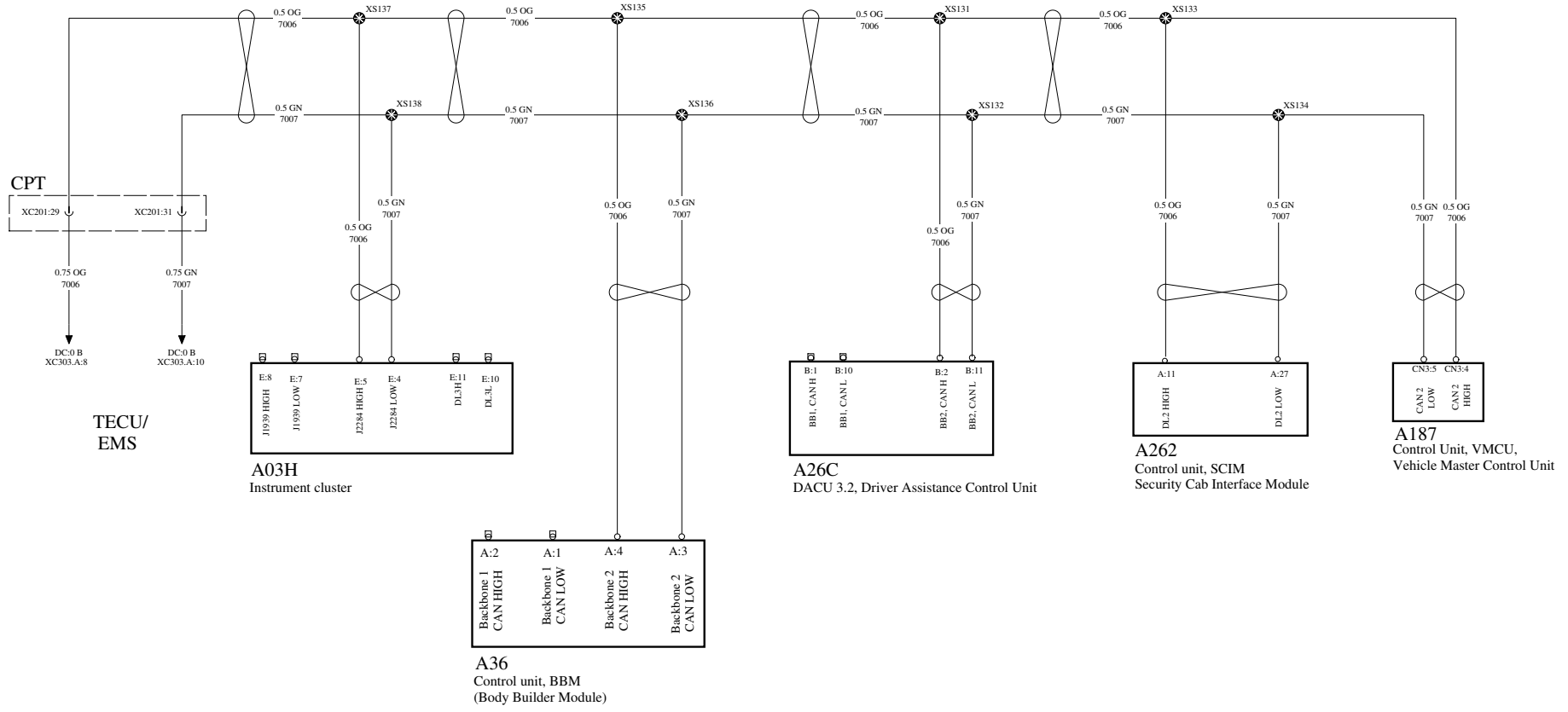

CAB SUBNET

WIRING DIAGRAM SC

CAB SUBNET BASE WITHOUT SRS SLEEPER (739) / DAY CAB (741)

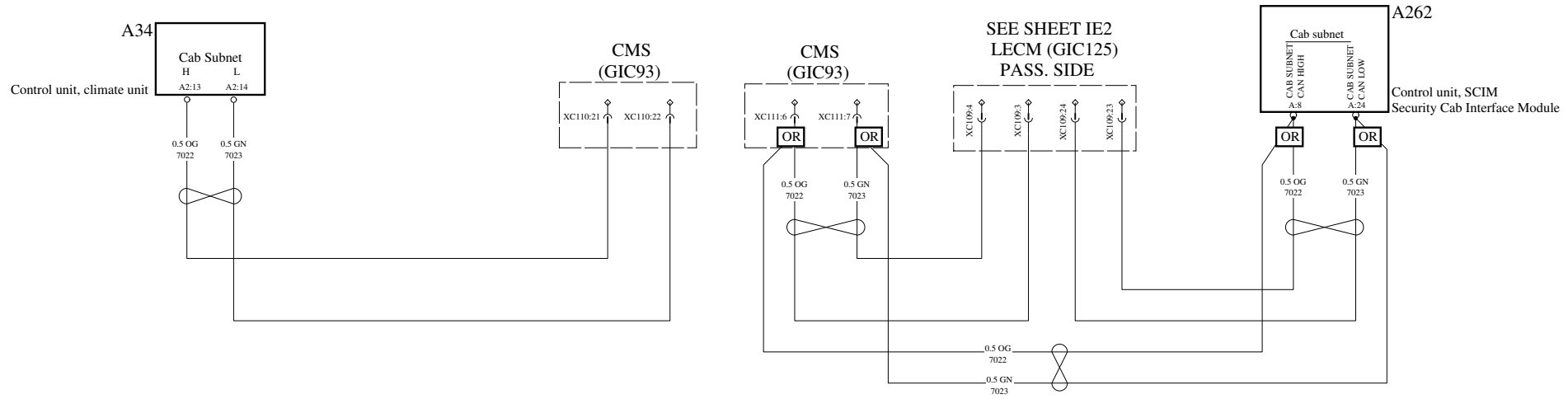

CAB SUBNET BASE WITH SRS SLEEPER (740) / DAY CAB (742)

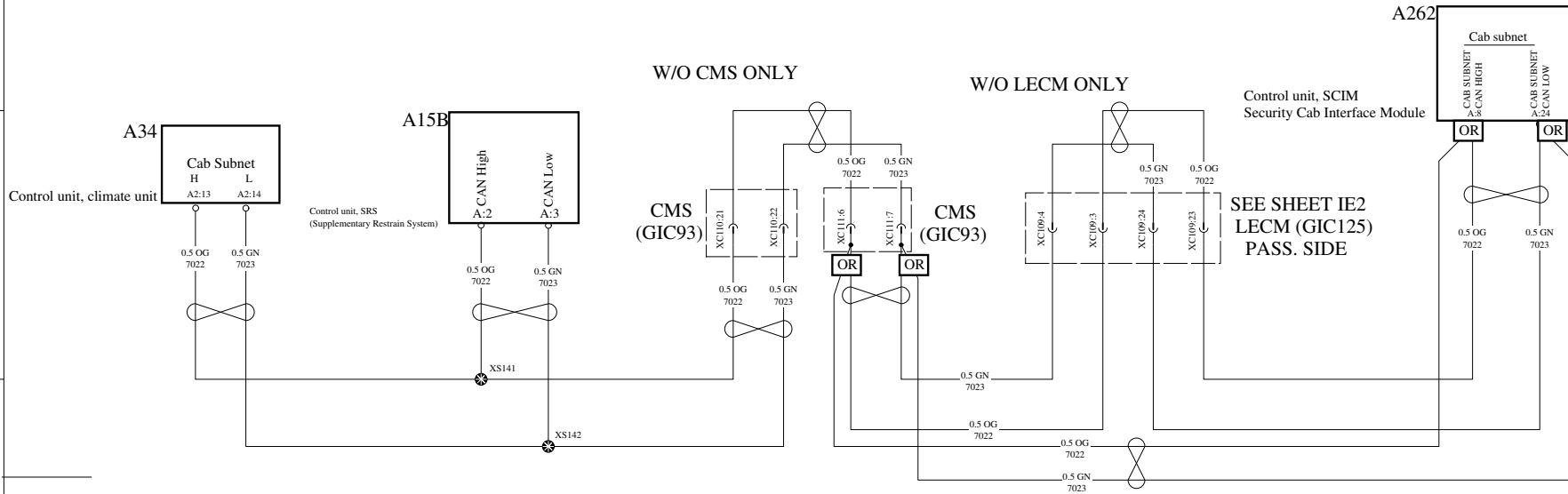

Document title
WIRING DIAGRAM, TEA2+ DIESEL

Legal Owner
Volvo Truck Corporation

Document No

24798720

Issue

01

Volume

1(1)

Page

103 (125)

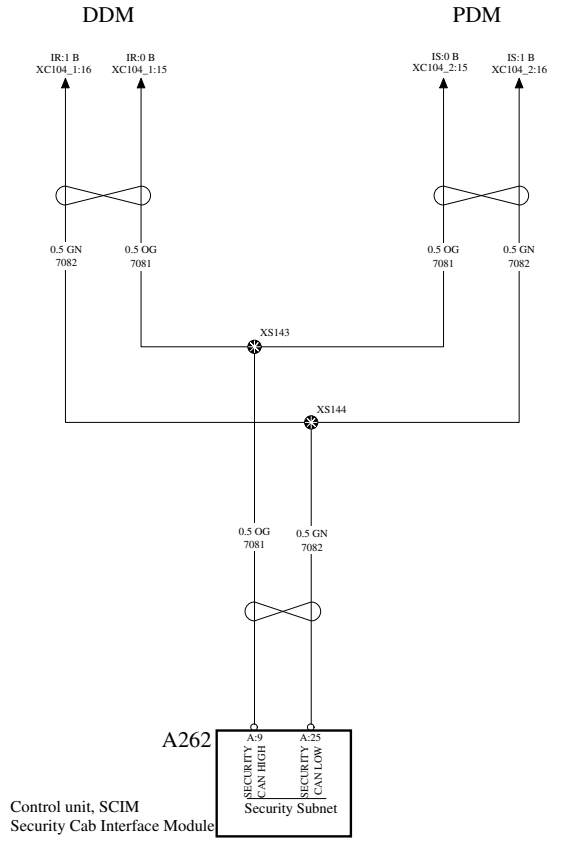

CHASSIS SUBNET

FUNCTION ARCHITECTURE

CHASSIS SUBNET (224) BASE

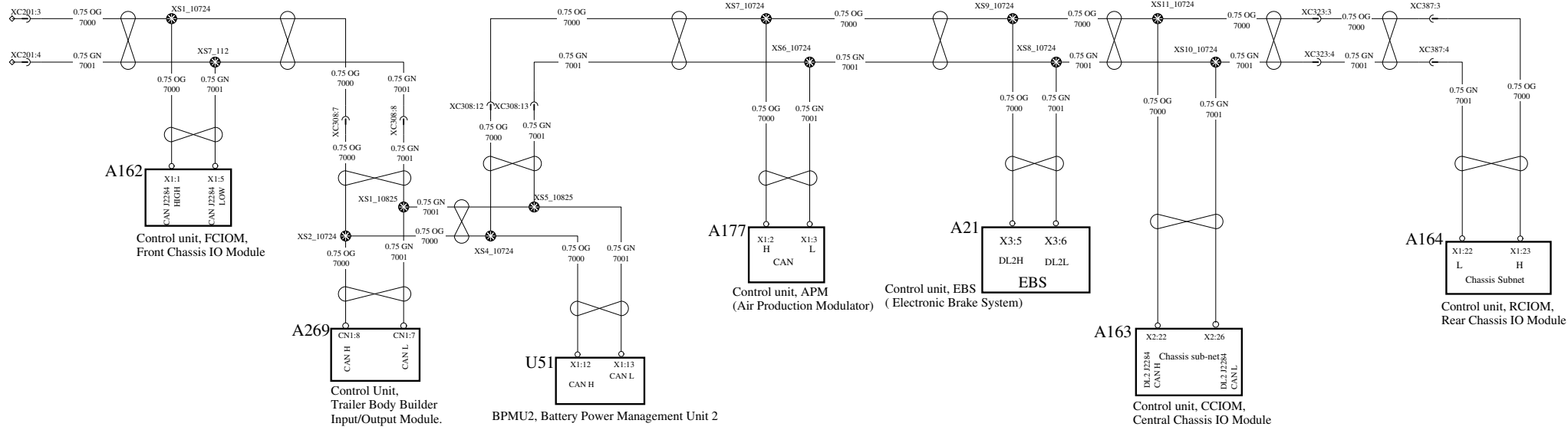

CHASSIS SUBNET (225) BASE W/TPM

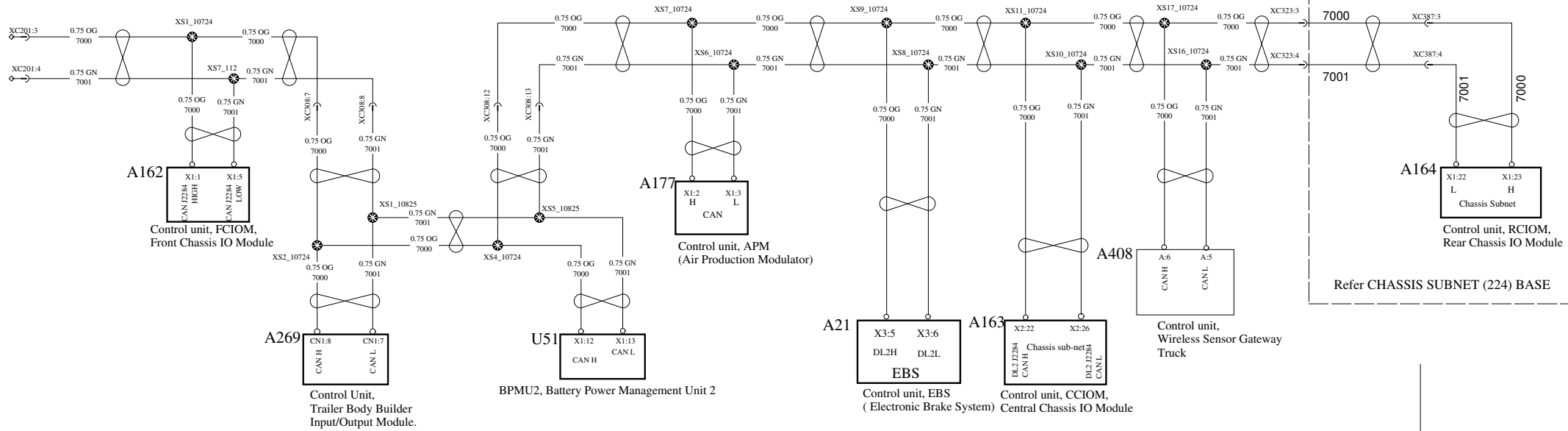

Document title
WIRING DIAGRAM, TEA2+ DIESEL

Legal Owner
Volvo Truck Corporation

Document No

24798720

Issue

01

Volume

1(1)

Page

105 (125)

CHASSIS SUBNET

WIRING DIAGRAM SF

CHASSIS SUBNET (226) BASE W/FAS

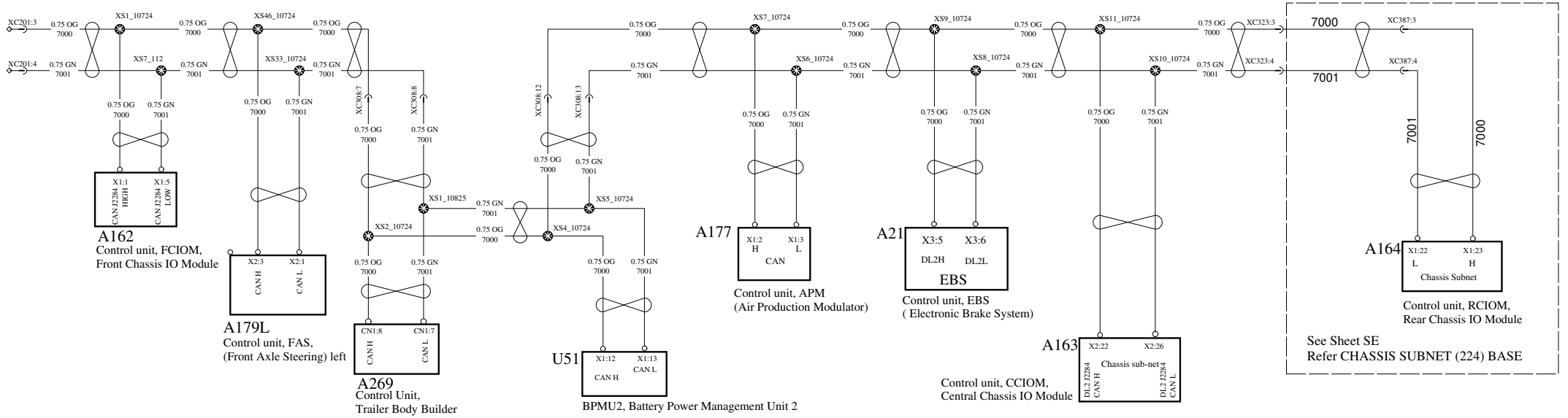

CHASSIS SUBNET (229) W/FAS & TPM

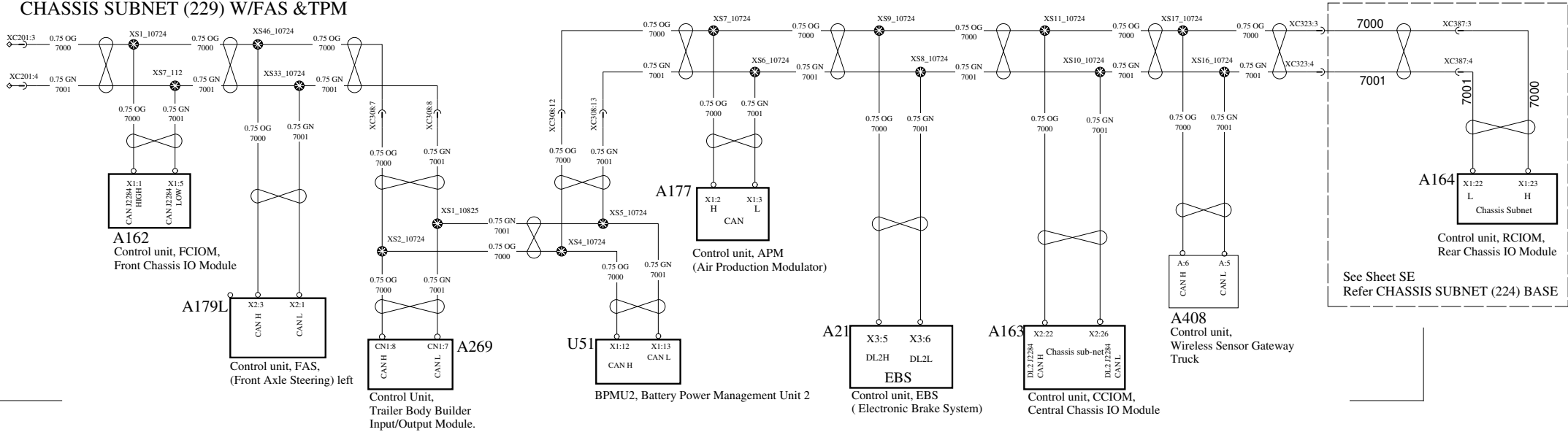

Document title
WIRING DIAGRAM, TEA2+ DIESEL

Legal Owner
Volvo Truck Corporation

Document No

24798720

Issue

01

Volume

1(1)

Page

106 (125)

INFOTAINMENT SUBNET REM WITHOUT TGW (744)

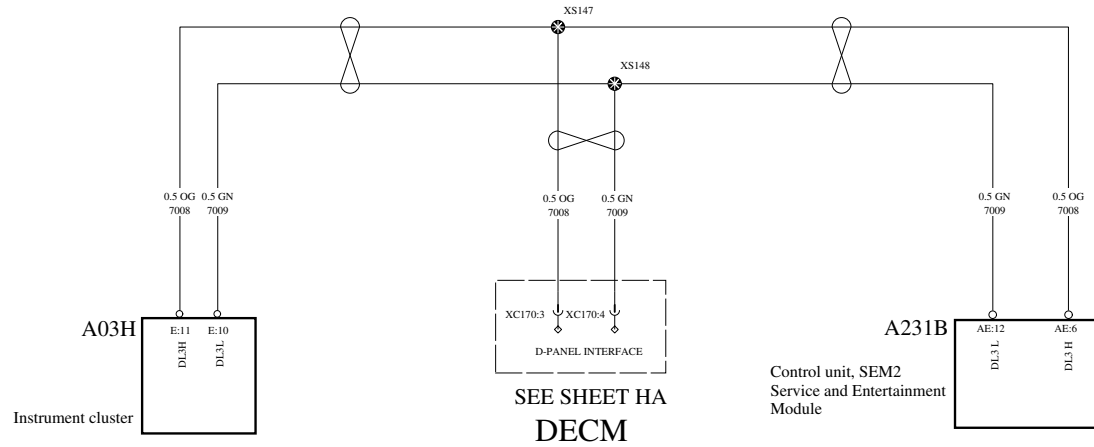

INFOTAINMENT SUBNET WITH REM/SEM AND TGW (745)

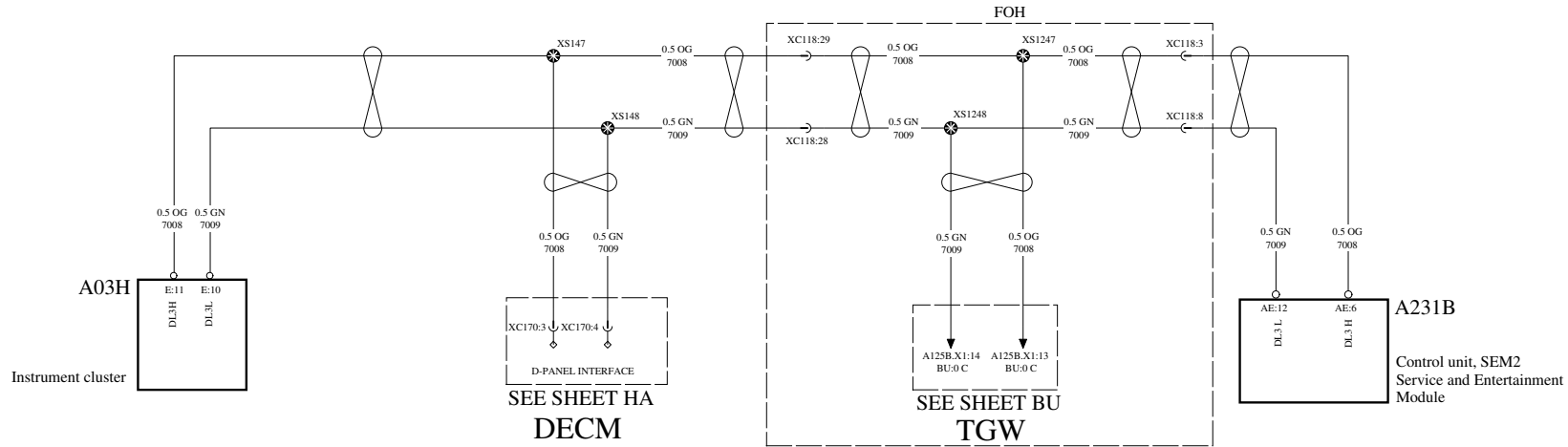

SWITCH TOPOLOGY

CAB SUBNET - LIN NETWORK

WIRING DIAGRAM SK

A

A

B

B

C

C

D

D

E

E

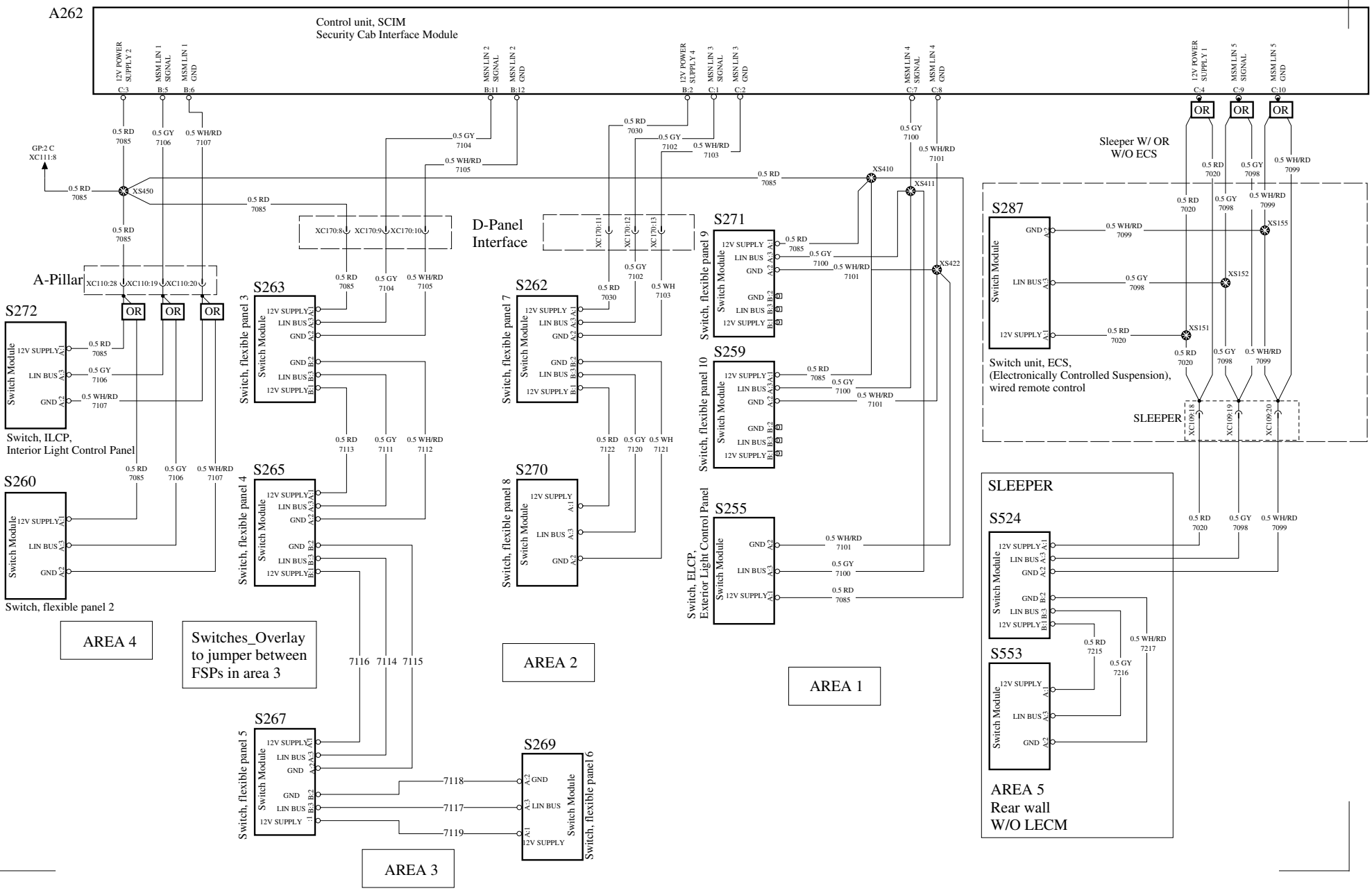

Document title
 WIRING DIAGRAM, TEA2+ DIESEL
 Legal Owner
 Volvo Truck Corporation

Document No	Issue	Volume	Page
24798720	01	1(1)	108 (125)

0

1

2

3

4

SWITCH TOPOLOGY MACK AREA 1 - 3

WIRING DIAGRAM SK1

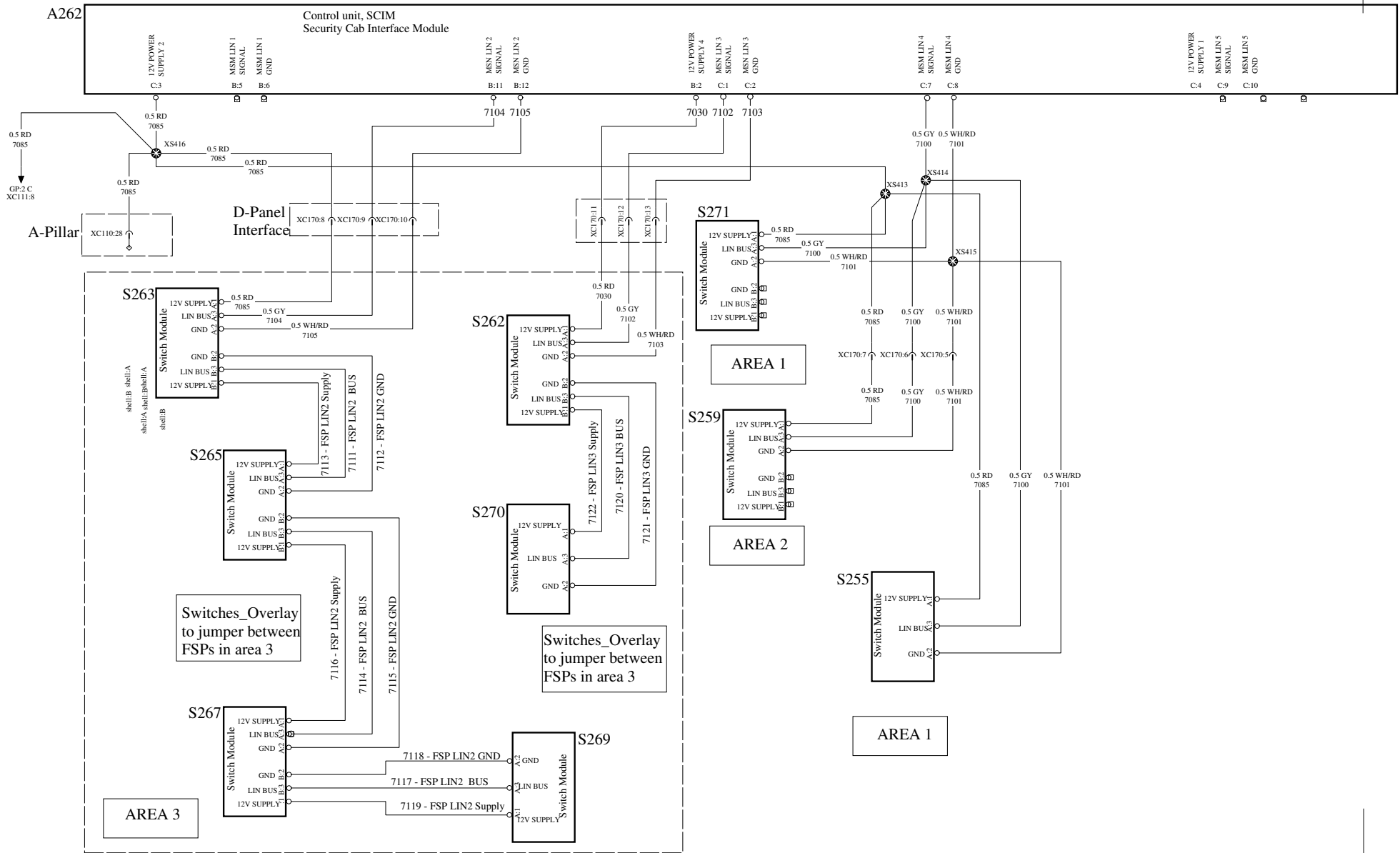

Document title
WIRING DIAGRAM, TEA2+ DIESEL

Legal Owner
Volvo Truck Corporation

Document No

24798720

Issue

01

Volume

1(1)

Page

109 (125)

A262

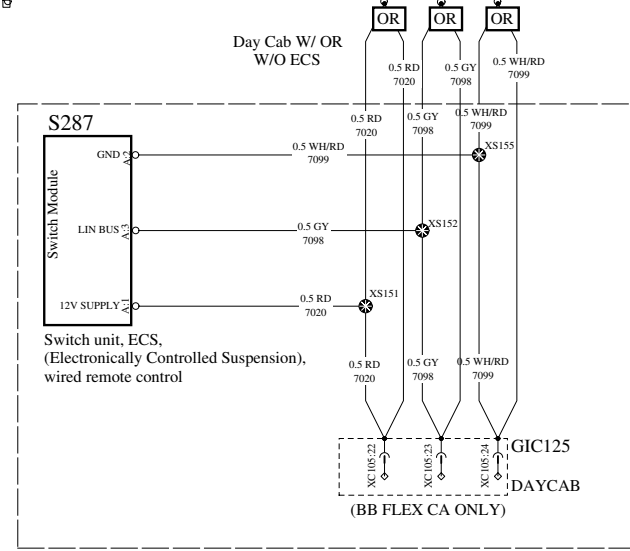
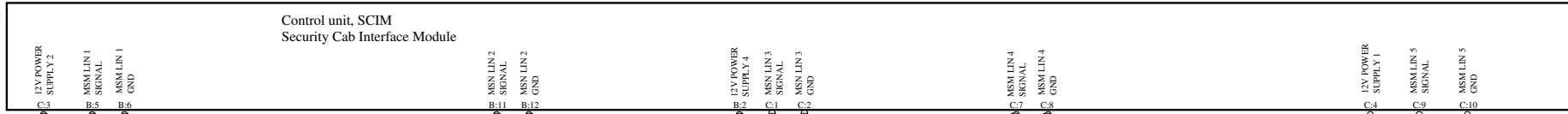

Document title
WIRING DIAGRAM, TEA2+ DIESEL

Legal Owner
Volvo Truck Corporation

Document No

24798720

Issue

01

Volume

1(1)

Page

110 (125)

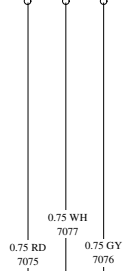
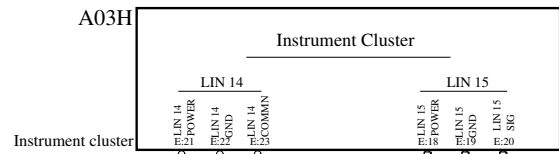

X115A
Contact reel,
airbag

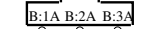
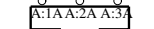

STEERING WHEEL SWITCHES (SWS)

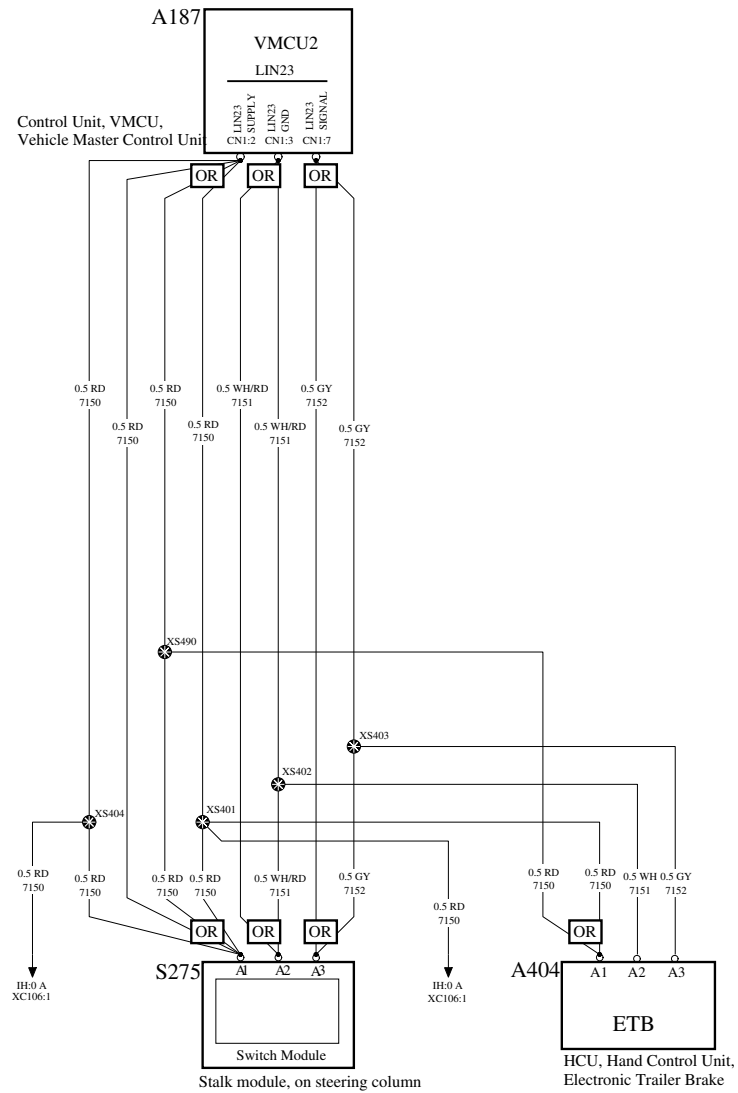

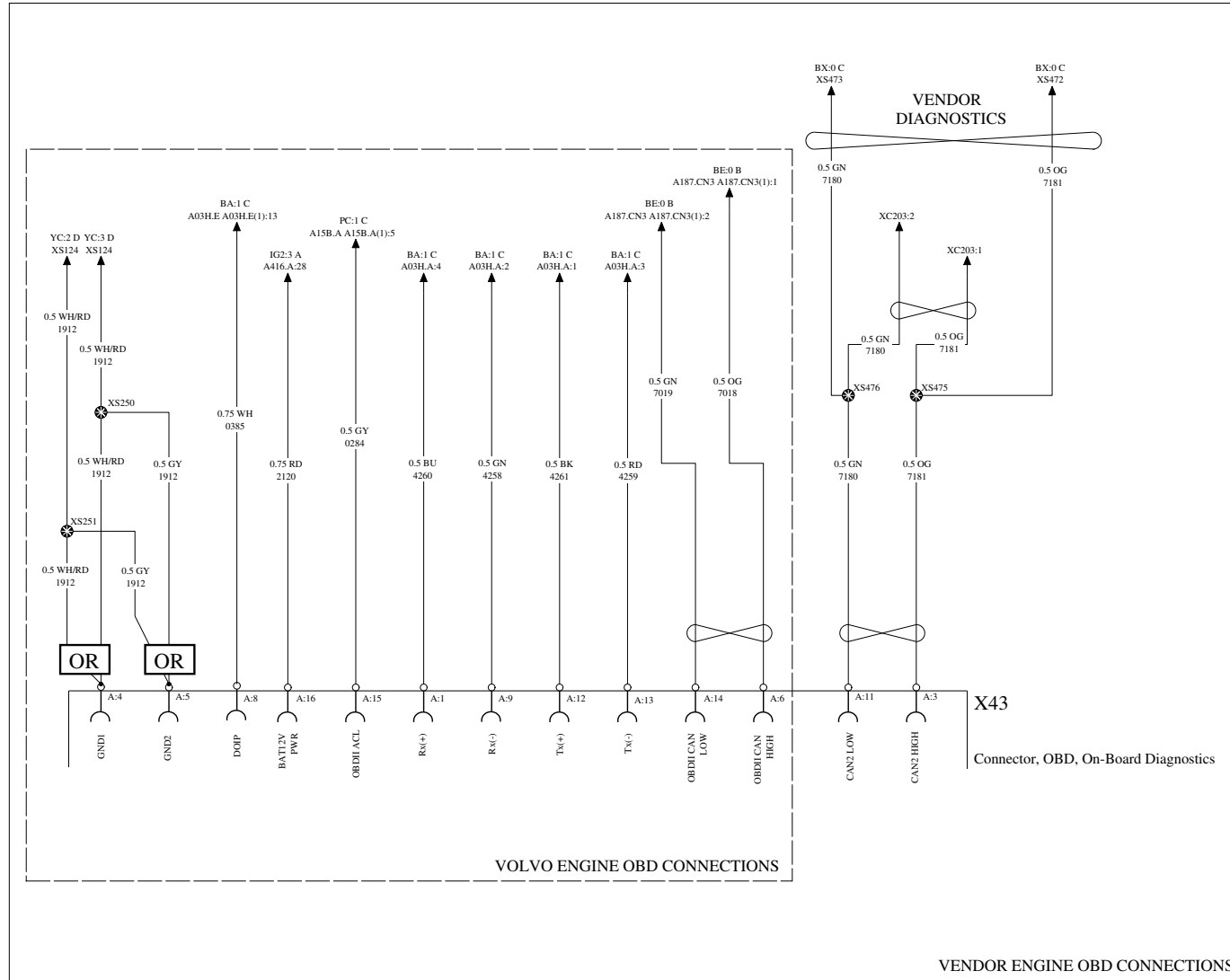

DL1 (J1939) VOLVO BASE TO GIC21 (101)

DL1 (J1939) VOLVO BASE FROM GIC21 (102)

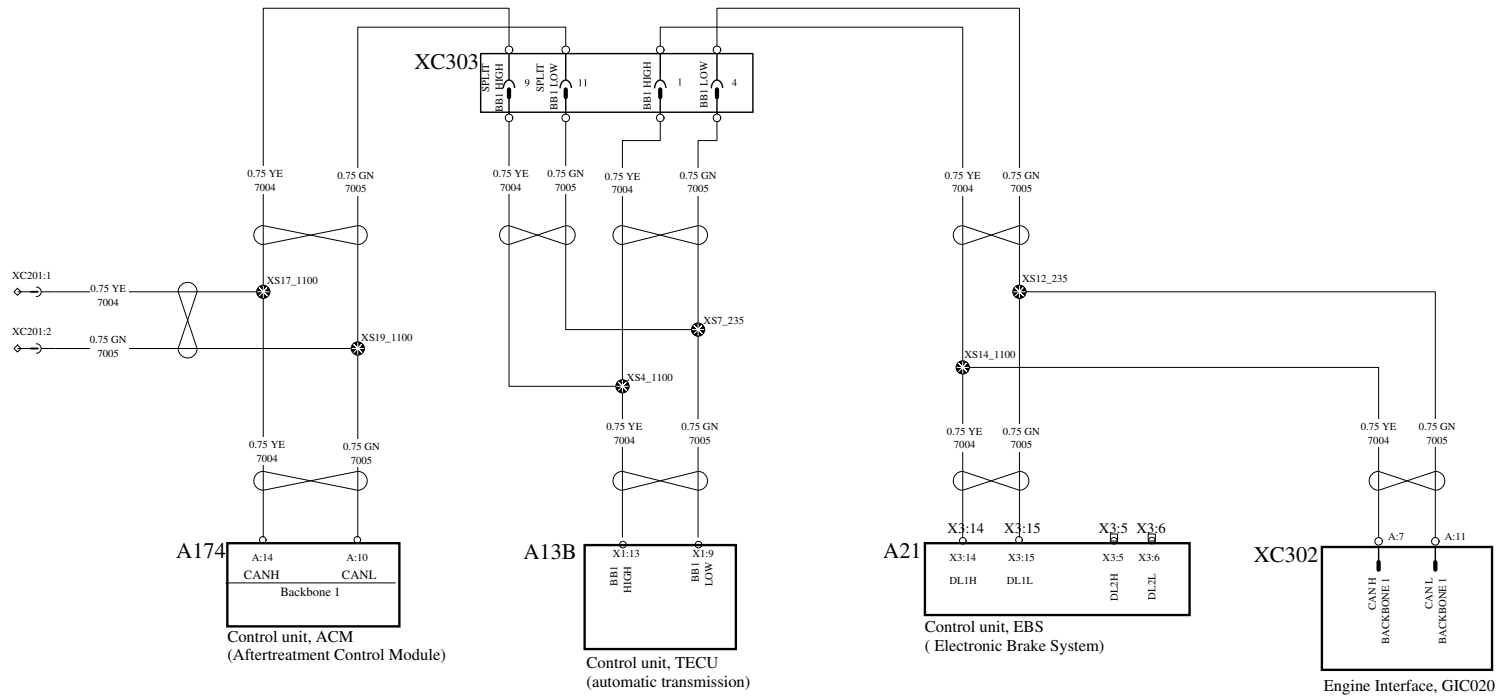

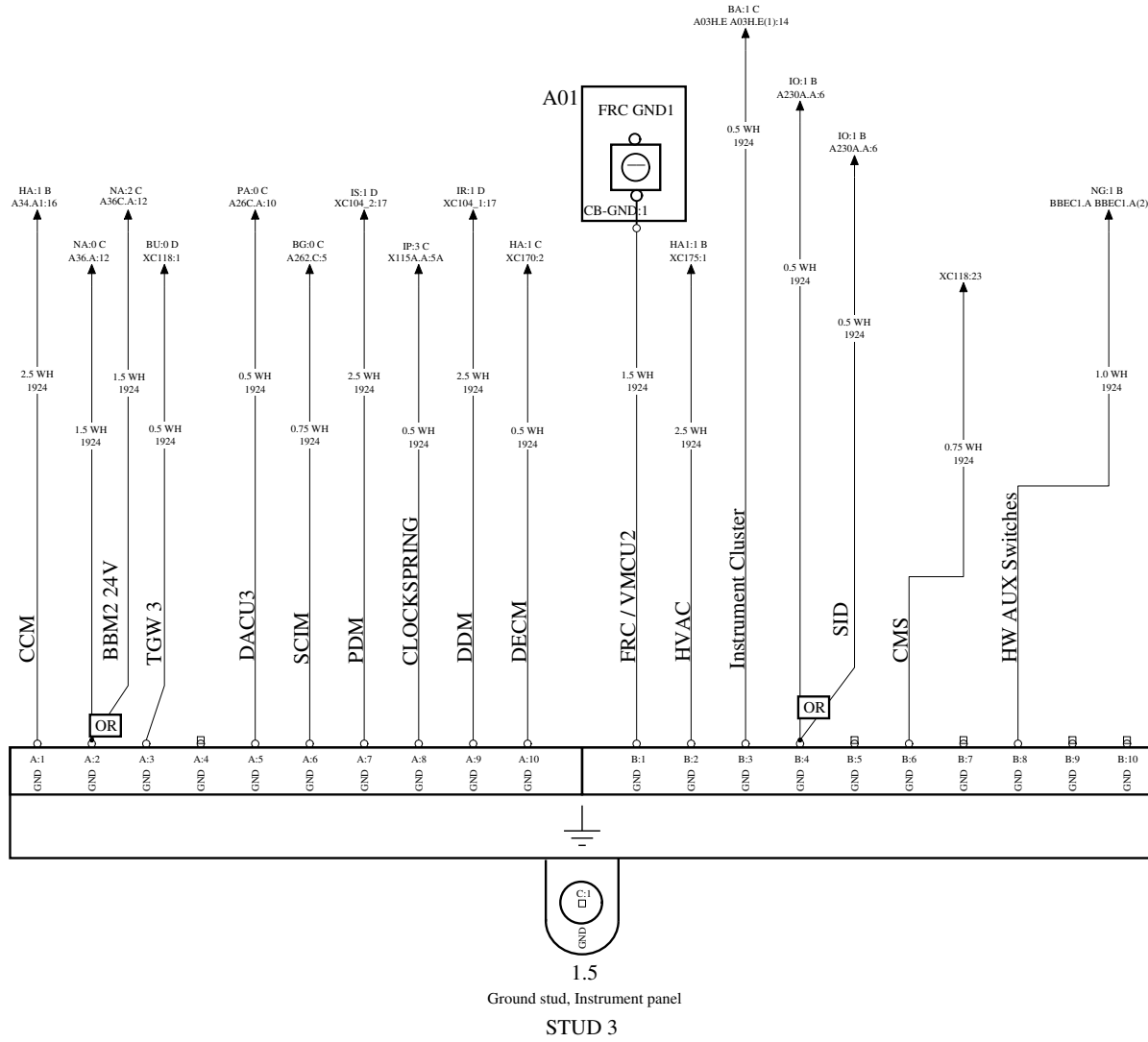

V O L V O

Document title
WIRING DIAGRAM, TEA2+ DIESEL

Legal Owner
Volvo Truck Corporation

Document No

24798720

Issue

01

Volume

1(1)

Page

114 (125)

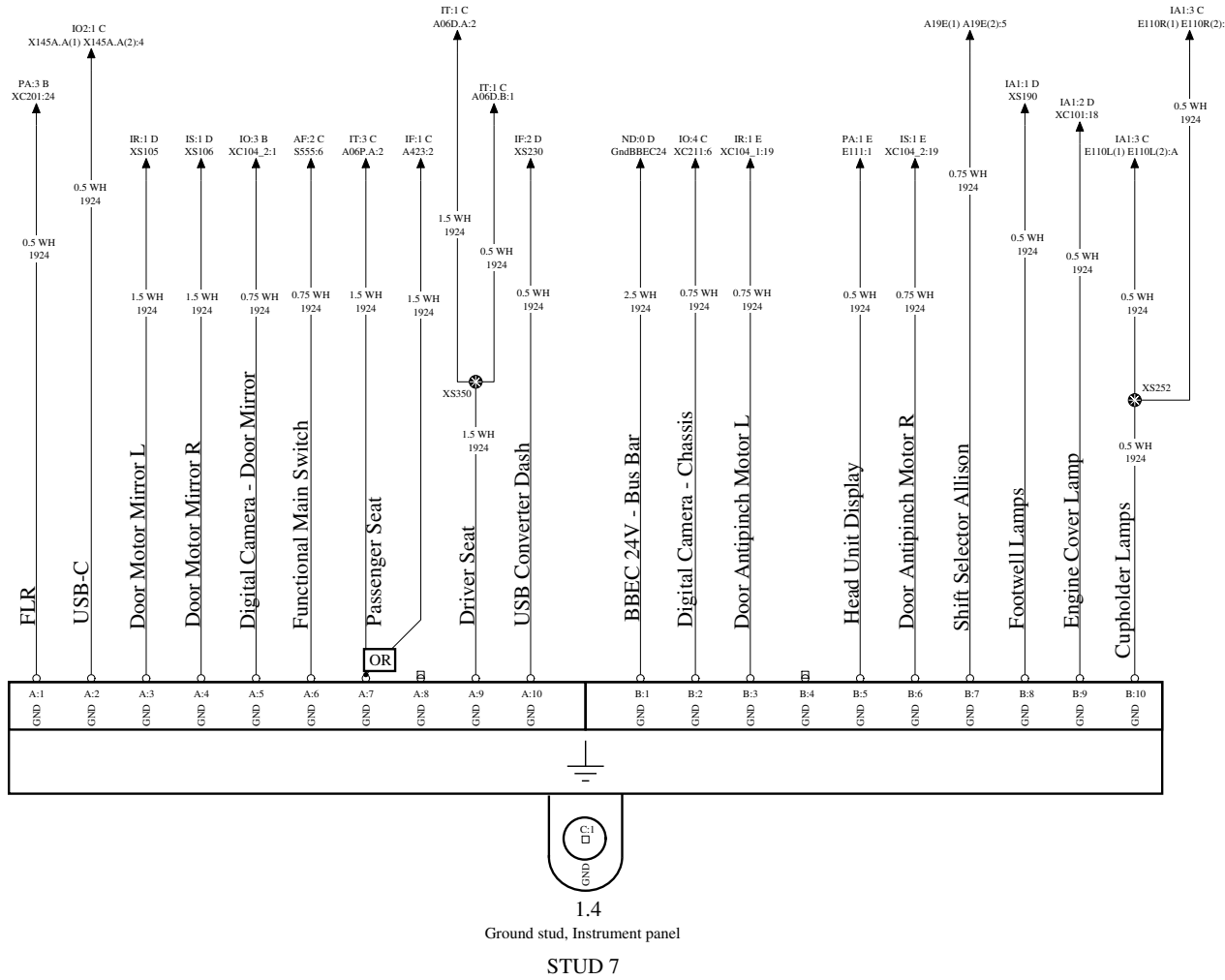

BIW - CAB GROUND INSTUMENT PANEL

12V GND

WIRING DIAGRAM YC

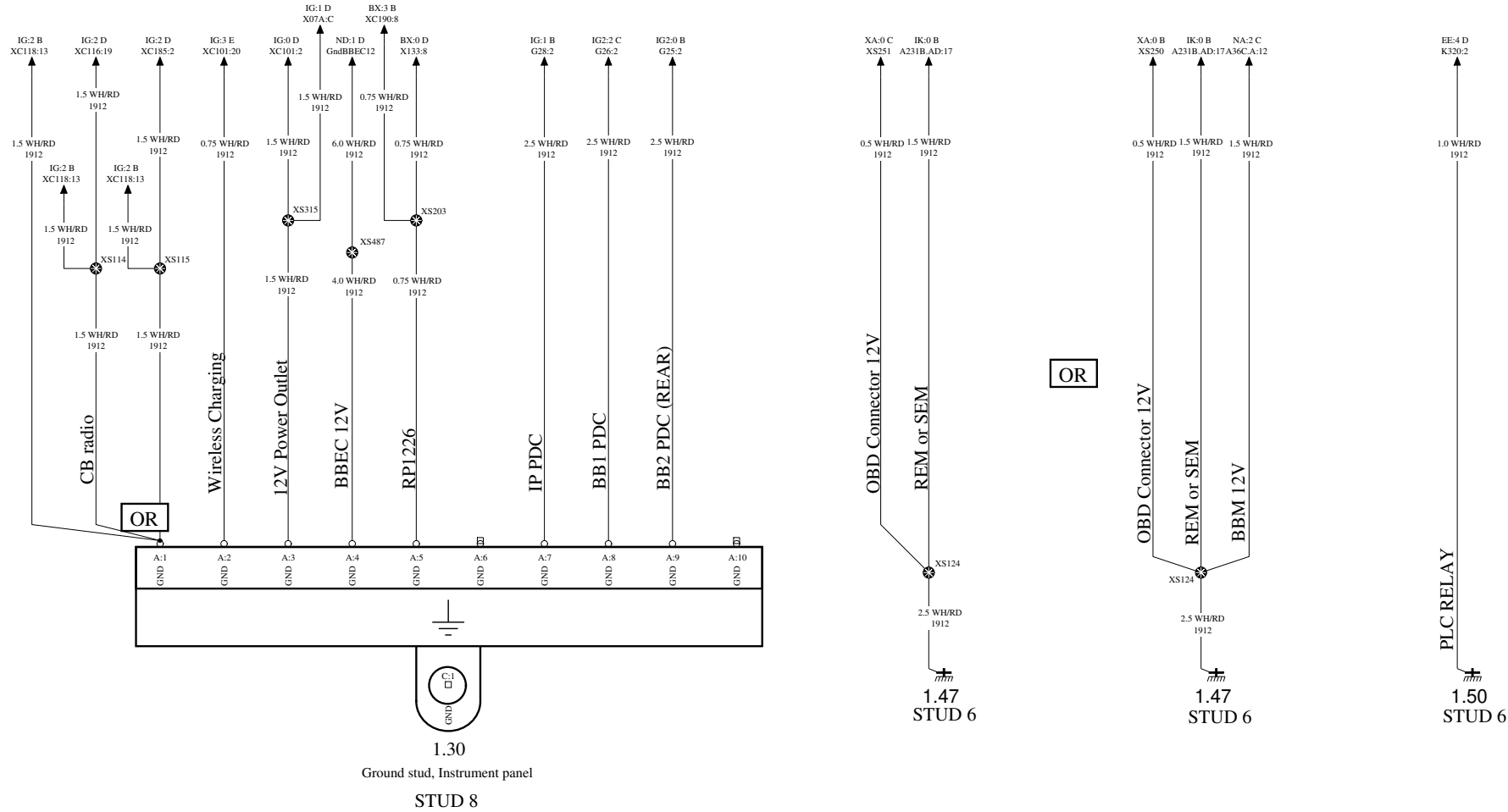

V O L V O

Document title
WIRING DIAGRAM, TEA2+ DIESEL

Legal Owner
Volvo Truck Corporation

Document No

24798720

Issue

01

Volume

1(1)

Page

116 (125)

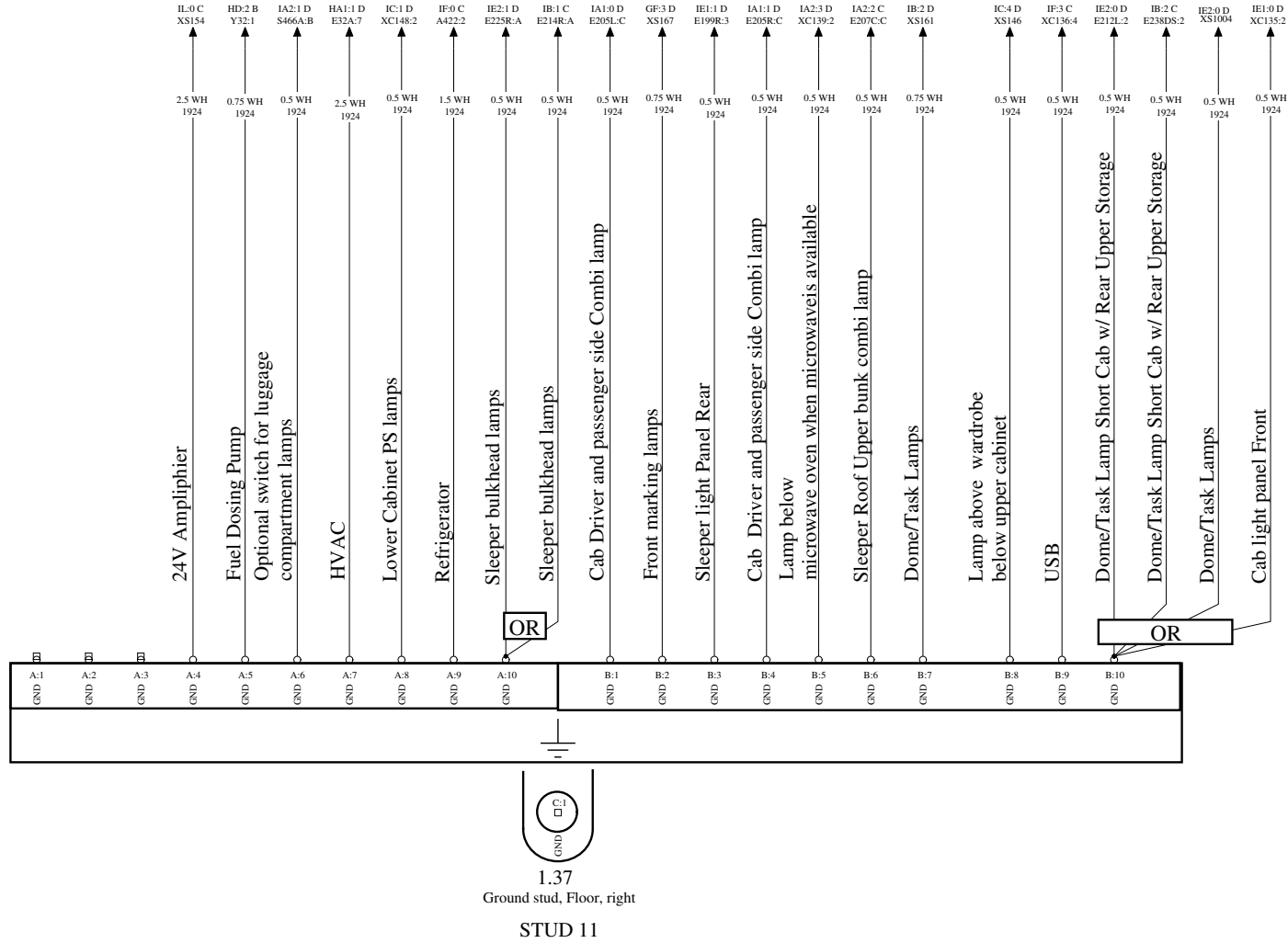

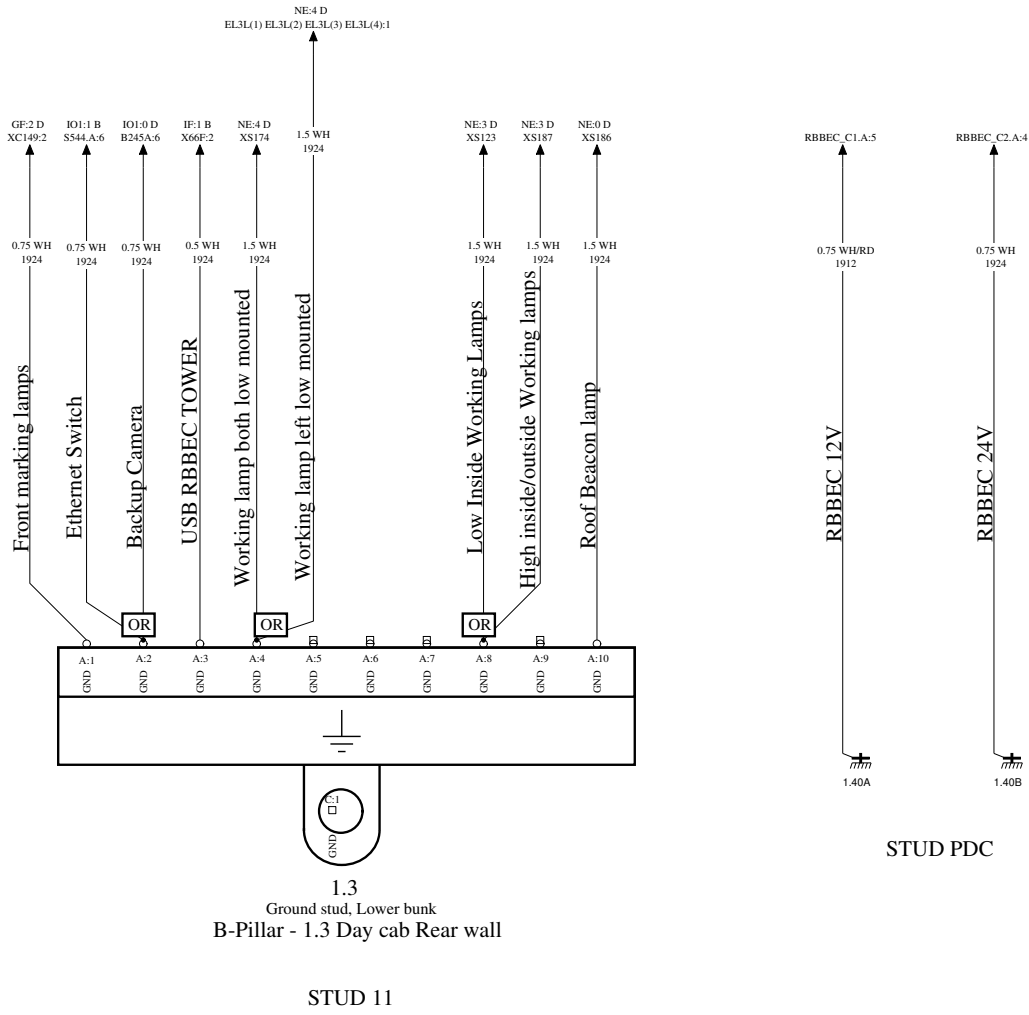

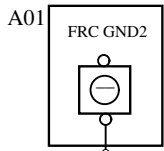

CB-GND:2

4.0 WH
1924

FRC/VMCU

1.61
Power 24V GND
STUD 4

PC:1 D
XS471

1.0 WH
1924

SRS

1.51
Signal 24V GND
STUD 5

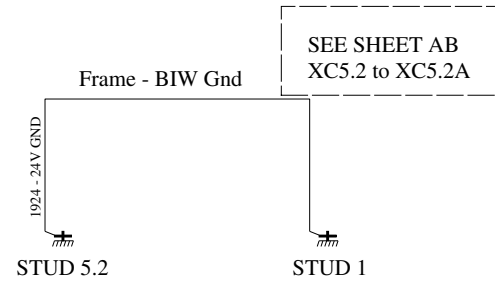

CHASSIS GND

LEFT HAND FRAME

WIRING DIAGRAM YF

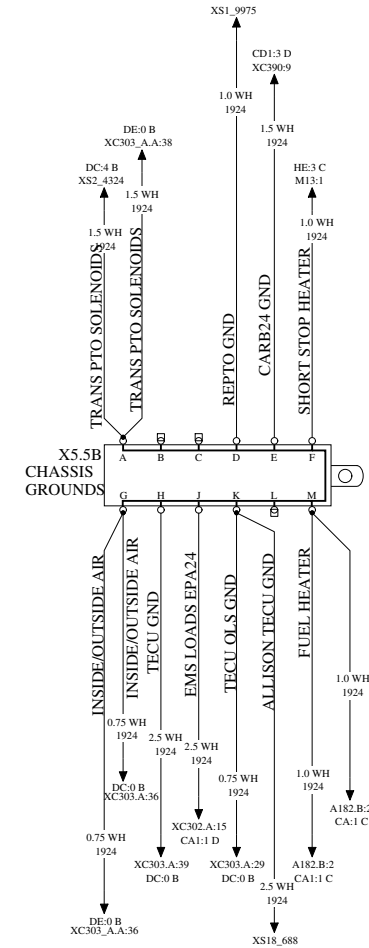
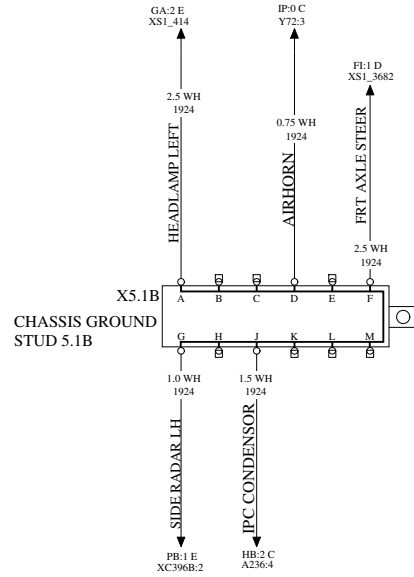
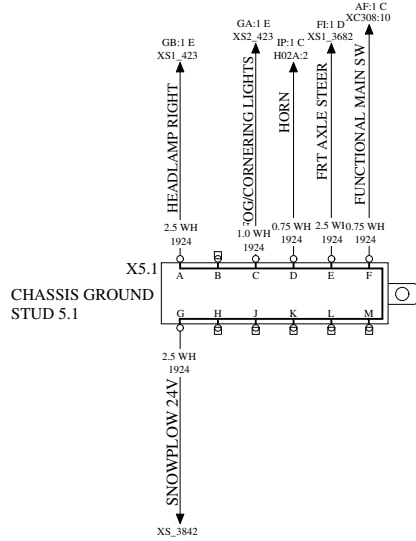

Document title
WIRING DIAGRAM, TEA2+ DIESEL

Legal Owner
Volvo Truck Corporation

Document No

24798720

Issue

01

Volume

1(1)

Page

120 (125)

CHASSIS GND

LEFT HAND FRAME

WIRING DIAGRAM YG

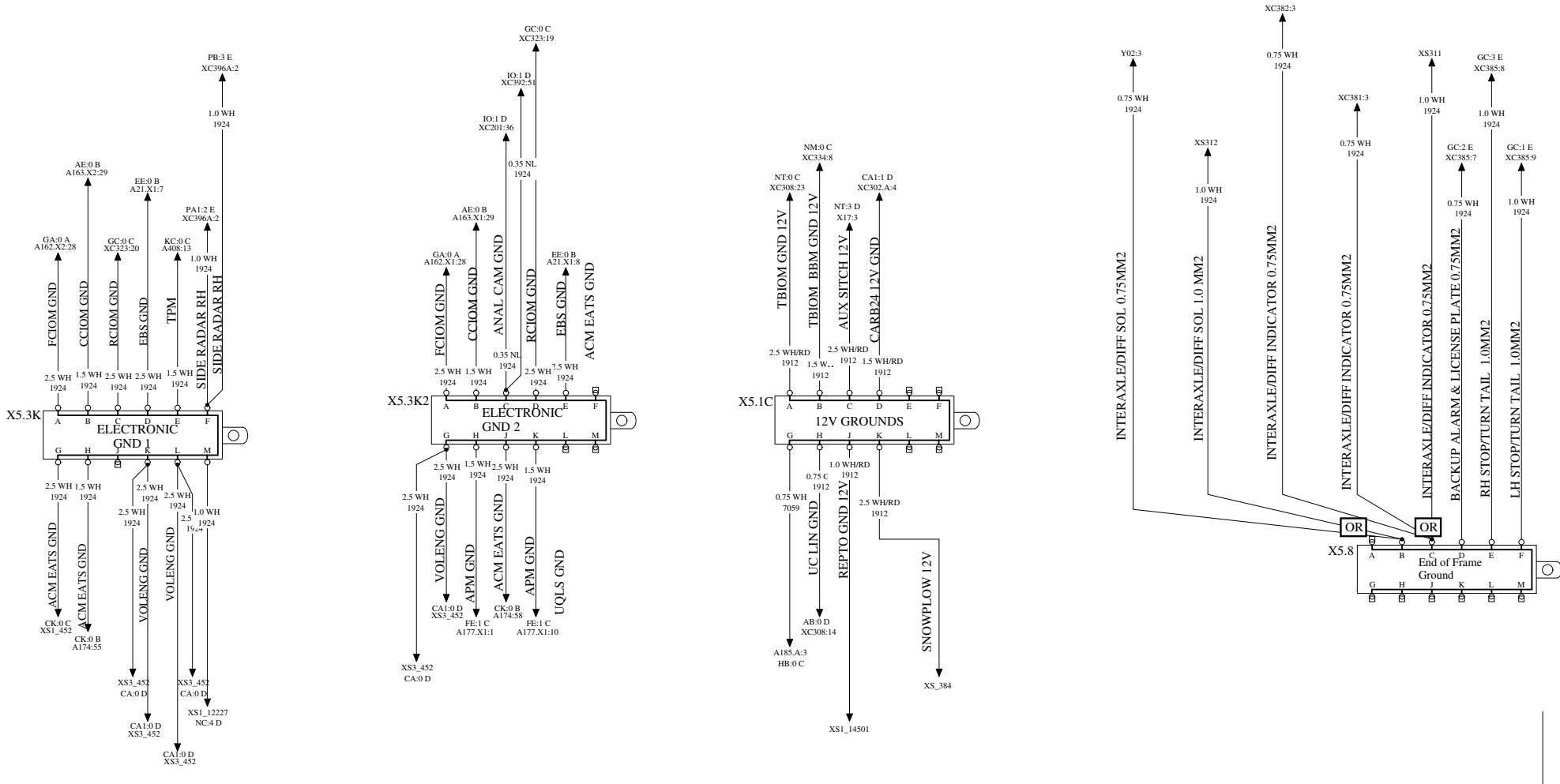

Document title
 WIRING DIAGRAM, TEA2+ DIESEL
 Legal Owner
 Volvo Truck Corporation

Document No

24798720

Issue

01

Volume

1(1)

Page

121 (125)

0 CHASSIS GROUND

1 LEFT HAND FRAME

3 WIRING DIAGRAM YH

4

A

A

B

B

C

C

D

D

E

E



V O L V O

Document title
WIRING DIAGRAM, TEA2+ DIESEL

Document No

Issue

Volume

Page

Legal Owner
Volvo Truck Corporation

24798720

01

1(1)

122 (125)

0

1

2

3

4

BIW - CAB GROUND

POWER 12V GND

WIRING DIAGRAM YJ

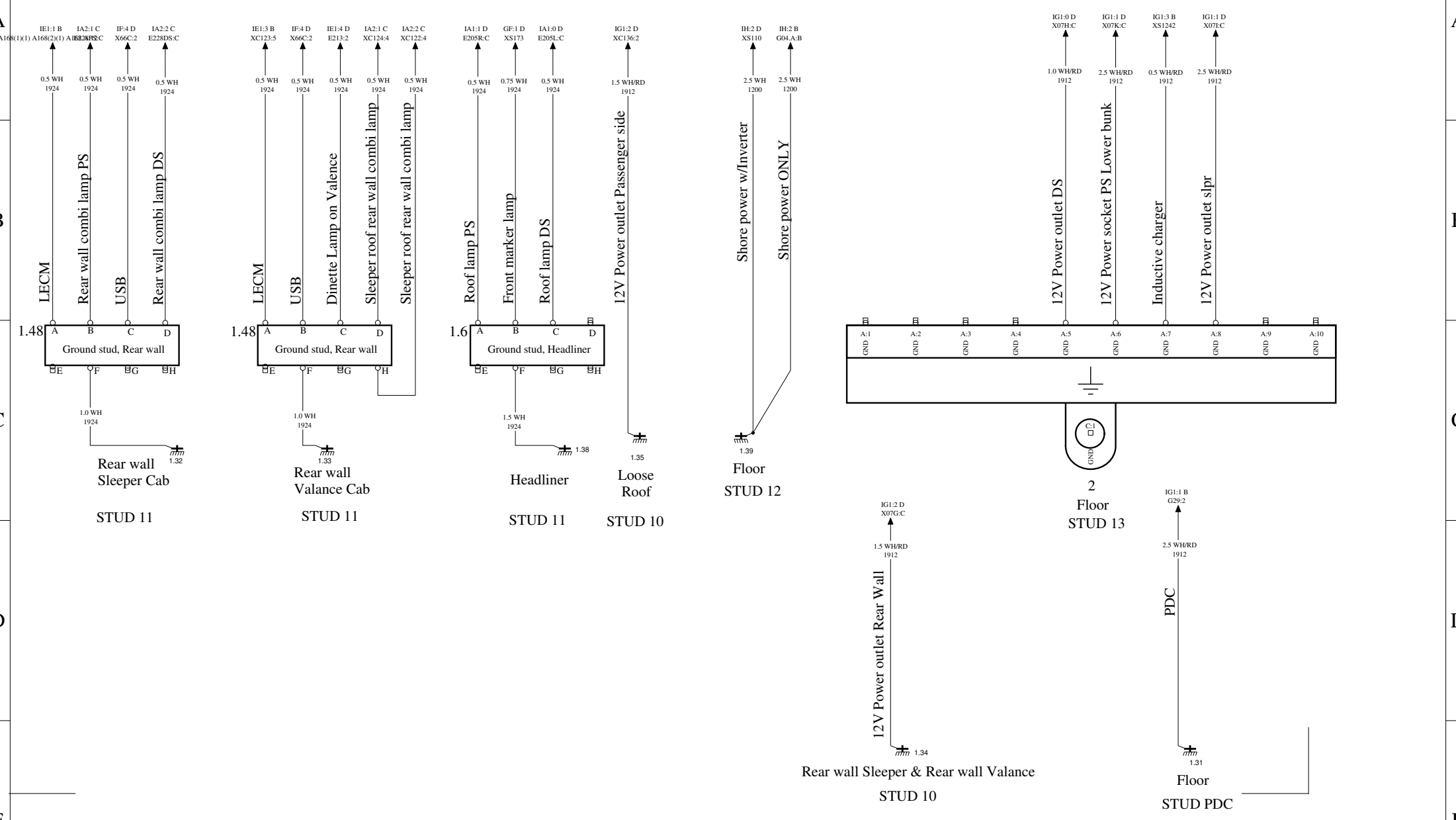

Document title WIRING DIAGRAM, TEA2+ DIESEL		Document No	Issue	Volume	Page
Legal Owner Volvo Truck Corporation		24798720	01	1(1)	123 (125)

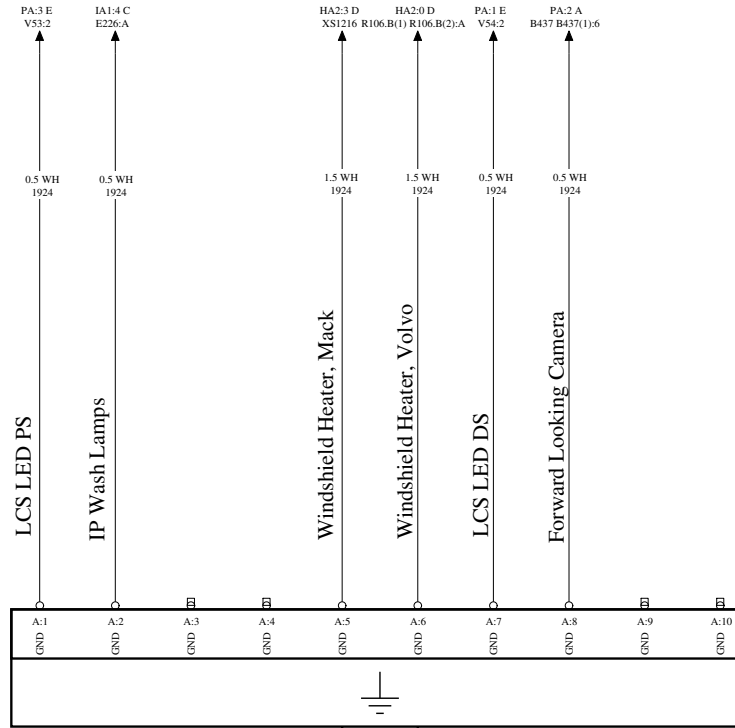

1.8
Ground stud, Front shelf
Front Overhead
STUD 9



Document title
WIRING DIAGRAM, TEA2+ DIESEL

Legal Owner
Volvo Truck Corporation

Document No

24798720

Issue

01

Volume

1(1)

Page

124 (125)

